

The D. H. Hill Library



North Carolina State University

SF239

W78

NC STATE UNIVERSITY D.H. HILL LIBRARY



S00260501 E

THIS BOOK IS DUE ON THE DATE INDICATED BELOW AND IS SUBJECT TO AN OVERDUE FINE AS POSTED AT THE CIRCULATION DESK.

MAY 25 1982

APR 23 1984

MAY 11 1990

MAR 15 1993

APR 28 1994

MAR 24 1999
APR 23 1999

APR 23 1999

APR 23 1999

JUN 11 2002

100M/177

N. C. COLLEGE OF A. & M. A.
Dept. of Botany

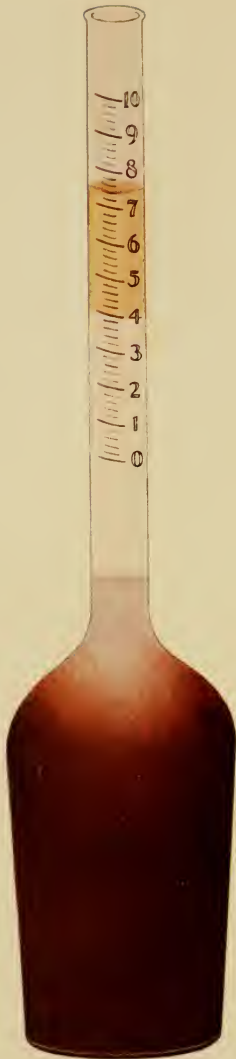

THE
PRODUCTION AND HANDLING
OF
CLEAN MILK

INCLUDING
PRACTICAL MILK INSPECTION

BY
KENELM WINSLOW, M.D.; M.D.V.; B.A.S. (*Harv.*)

*Formerly Instructor in Bussey Agricultural Institute and Assistant
Professor in the Veterinary School of Harvard University.
Author of a text book on Veterinary Materia Medica
and Therapeutics, Chairman of the Committee
on Milk of the Washington State
Medical Association, etc.*

AND
ESSENTIALS OF MILK BACTERIOLOGY

BY
H. W. HILL, M.D.

*Minnesota State Board of Health Laboratories, Chairman of the Committee on
Laboratories of the American Public Health Association, formerly Director
Boston Board of Health Bacteriological Laboratory*



NEW YORK
WILLIAM R. JENKINS CO.
PUBLISHERS
851 & 853 SIXTH AVENUE

*M. C. COLLEGE OF A. & M. A.
Dept. of Botany*

Copyright, 1907, 1909
BY WILLIAM R. JENKINS CO.
All rights reserved

[Registered at Stationers' Hall, London]
Printed in the United States of America

PRINTED BY THE
PRESS OF WILLIAM R. JENKINS CO.
NEW YORK

PREFACE TO SECOND EDITION

The writer and publishers feel gratified that a second edition of this work is called for within a little over a year from its first appearance.

Such rapid advances have occurred in the knowledge of subjects herein treated that it has been found necessary to very materially add to and alter the former text—so much so, that many chapters of the present volume have been re-written and very considerably expanded.

The attempt has been made in this revision to so extend the scope of the original work as to supply to veterinary, agricultural and dairy students, and to health officers, a text-book on practical milk inspection and dairy hygiene, which are becoming of such importance to the public health.

Moreover, the author has had the advantage of the collaboration of Dr. H. W. Hill, whose work in milk bacteriology is well known.

The writer also desires to acknowledge his grateful indebtedness to Professor Conn for his generosity in permitting the use of the laboratory experiments in dairy bacteriology.

Both of these additions should prove of great benefit to students of milk bacteriology.

KENELM WINSLOW.

SF 234
W78

16719

PREFACE TO FIRST EDITION

The writer is a graduate in agricultural science, in veterinary and human medicine, and has been connected with a laboratory in which is examined the milk supply of a large city, and finally has had considerable practical experience in the production and distribution of clean milk.

These facts are simply mentioned to show that the book is written from various points of view.

Much blame is attached to sundry persons engaged in vending milk, but the unfortunate farmer is apt to receive an unjust share because of the commonly unclean and therefore unsanitary condition of most market milk. While city contractors and dealers may have much influence in instructing and requiring the farmer to live up to recognized standards of cleanliness, yet, after all, the chief responsibility lies with the consumer. The essential object in the clean milk crusade should be to awaken the public to the dangers of unclean milk and to emphasize the fact that it is impossible to produce and obtain clean milk except at unusual expense.

When the public is sufficiently aroused to the evils of consuming unclean milk and evinces willingness to pay for clean milk, there will be no difficulty about its production. It is merely a question of supply and demand.

PREFACE

It is not generally known that the farmer sometimes receives but one-quarter of the retail price of milk (frequently but 2 cents a quart), and he can hardly be expected to undertake a considerably increased expenditure for the production of clean milk—this being the case.

There is probably more interest being shown in this and other countries in a pure milk supply than ever before. For this reason it should be a comparatively easy task for any individual desiring to produce clean milk in any considerable community to find a sufficient patronage, particularly if the local medical profession is asked to assist, always providing that the proper standard is constantly and conscientiously maintained. The idea of financial return must be subordinated to this, and yet a reasonable profit can and must be had to sustain the required standard.

The aim of this book is to provide a working guide for those pursuing or wishing to pursue one of the most wholesome, worthy and laudable undertakings—the production of clean milk.

Most of the books at our command either touch the subject in a general manner or else describe special phases of it in detail. The attempt has here been made to cover the whole ground in as small compass as possible. That such an attempt must fall short the author is aware, as the topic of feeding cows alone (accorded but a chapter in this book) can only be fully treated in a large volume devoted wholly to this subject.

Objection may be made to the recommendation of particular apparatus of certain manufacturers. But the

PREFACE

writer has been so desirous of making the book practical that it has been deemed essential to choose special appliances in order to avoid generalities and vagueness.

While endeavoring to select the best, it does not follow that other appliances are not as good, or even better than those advised; but the author can truthfully affirm that both he and his publisher are entirely free from the remotest financial interest in advertising any special dairy appliances. Such appliances are undergoing the most wonderful and rapid improvement, almost from day to day.

KENELM WINSLOW.

CONTENTS

CHAP.	PAGE
I. GERMS IN THEIR GENERAL RELATIONS TO MILK	1
II. COMPOSITION OF MILK AND CREAM AND THEIR PRODUCTS	42
III. MILK PRODUCTS	54
IV. FEEDING FOR MILK	66
V. HOUSING AND CARE OF COWS	80
VI. HANDLING OF MILK AND CREAM	101
VII. COST OF PRODUCING AND DISTRIBUTING CLEAN MILK	146
VIII. SOME HINTS CONCERNING MILK DISTRIBUTION	162
IX. MILK INSPECTION	174
X. ESSENTIALS OF MILK BACTERIOLOGY	233
XI. QUANTITATIVE BACTERIAL ANALYSIS OF MILK	241
XII. MEDIA MAKING AND APPARATUS REQUIRED FOR BACTERIAL ANALYSIS OF MILK	262
XIII. CLASSIFICATION AND IDENTIFICATION OF BACTERIA— GLOSSARY—ADJUSTMENT OF REACTION OF MEDIA	281
XIV. LABORATORY WORK IN DAIRY BACTERIOLOGY	293
APPENDIX. DAIRY COWS, THEIR RECORDS AND VALUE— PLANS OF BARNs AND MILK HOUSES—MILKING MACHINES KEEPING ACCOUNTS—DISINFECTION—TUBERCULIN TEST- ING, ETC.	313
INDEX	359

LIST OF ILLUSTRATIONS

Frontispiece—Babcock Flask, showing fat in neck.

Fig.		Page
1	General Shape of Bacteria	4
2	The Constituent Elements of Milk	follows 44
	Sketch A—Two Methods of Ventilating a Dairy Barn	85
	Sketch B—Method of Ventilating a Lean-to Stable	86
	Sketch C—Section of the Cow Stable at the Wisconsin Experiment Station	87
	Sketch D—Showing Rutherford System of Ventilation	90
3	Cow Tail-holder	99
4	Good Type of Milking Suit and Pail	102
5	Iron Milking Stool	103
6	Milking Stool	103
7	The Gurler Milk Pail	104
8	A Recent Improvement of the Gurler Pail	104
9	Modification of Stewart's Milk Pail	105
10	Stadmueller Covered Pail	106
11	The North Covered Pail	106
12	The Trueman Covered Pail	107
13	Revolving Dairy Filter	108
14	Metal Frame on which Milk Pails are Set	109
15	The Conical Cooler	113
16	The Star Cooler	114
17	Tubular Cooler	114
18	Star Milk Cooler	115
19	Star Milk Cooler	115
20	Star Milk Cooler	116
21	Trap Milk Strainer	117
22	Covered Milk Cooler	119
23	Parts of Cooler	120

LIST OF ILLUSTRATIONS

Fig.		Page
24	An Arrangement of Cooler and Hand Bottle-Filler	121
25	Wash Sink	122
26	Various Forms of Brushes	123
27	Milk Can Jacket	124
28	Star Side-Bar Filler	125
29	Star High Pressure Sterilizer	126
30	Star Sterilizer	128
31	Bottle Brush	129
32	Star Metal Wash Sink	129
33	Star Bottle Washing Outfit	130
34	Steam Heating Tee	131
35	Glass Dairy Thermometer	132
36	Machine for Chopping Ice used to pack about milk bottles .	133
37	Banjo Conductor for carrying milk through a wall	134
38	Cylinder for conveying milk through a floor	134
39	Cream Cooler connected with Separator	135
40	Cream Bottle Filler	136
41	Bottle Carriers	137
42	Car for conveying Carriers and Bottles	138
43	Car for conveying Carriers and Bottles	139
44	Wagon Box for carrying bottles on ice	139
45	Star Milk Bottles	140
46	Paper Bottle Filling and Capping Machine	follows 140
47	Hand Separator for separating cream from milk	143
48	Milk Wagon	165
49	Milk Wagon	166
50	Delivery Basket	167
51	Method of Marking Parchment Caps for Certified Milk	169
52	Copper Case for Holding Bottle Caps	169
53	Dipper and Siphon for Removing Cream from Bottles	follows 172
54	Small Babcock Machine	193
55	Eight-Bottle Babcock Machine	194
56	Small Babcock Machine	194
57	Pipette for making the Babcock test	196
58	Shows method of Using Pipette for Babcock Test	196
59	Quevenne's Lactodensimeter	197

LIST OF ILLUSTRATIONS

Fig.		Page	
60	Tubes for Hart's Casein Test	201	
61	Feser's Lactoscope	203	
62	Collecting Case for Milk Samples	252	
63	Petri Dishes	257	
64	Pipettes	258	
65	Petri Dish Showing Colonies of Bacteria . . follows	260	
66	Counting Box	261	
67	Filling Test Tubes with Culture Medium	268	
68	Hardening Agar Slants	273	
69	Two Burettes arranged for Titrating Culture Media	288	
70	Platinum Needles	297	
71	Cutter for Making Potato Plugs	298	
72	Types of Surface Elevation	299	
73	Types of Gelatin Liquefaction	301	
74	Flasks and Vials for quantitative bacteriological analysis	308	
75	Yeksa Sunbeam (Guernsey)	} follow	316
76	Shadybrook Gerben (Holstein)		
77	Pansy of Woodroffe (Ayrshire)		
78	Loretta D (Jersey)		
79	Showing Stable of J. D. Farrell, Esq.	follows	322
80	Sketch of Ground Plan of Milk House		323
81	Showing Stable of J. D. Farrell, Esq.	} follow	324
82	Showing Washroom (J. D. Farrell, Esq.)		
83	Showing Milk Room (J. D. Farrell, Esq.)		
84	Interior of the Paulhamus Barn		
85	Sketch of Ground Plan of Barn for Forty Cows		325
86	Bottle Washing Machine at the Paulhamus Farm follows	326	
87	Sketch of Ground Plan of Milk House		327
88	Cement Sterilizer at the Paulhamus Farm	follows	328
89	Side and Rear View of Stall of Cow Stable		330
90	The Improved Drown Stall	follows	330
91	Swing Stanchion and Cross Section of Feed Trough		332
92	Stall with Panel Wooden Floor		333
93	Shows a Small Dairy House		333
94	Floor Plan of Small Plant for Certified Milk Connected with Barn		334

LIST OF ILLUSTRATIONS

Fig.		Page
95	Floor Plan of Creamery and City Milk Plant . . .	334
96	Front Elevation of Creamery and City Milk Plant . . .	335
97	Floor Plan of Creamery for Whole Milk . . .	335
98	The Burrell-Lawrence-Kennedy Cow Milker . follows	338
99	The Pulsator	“ 338
100	Illustrating the Hegelund Method of Milking . . .	“ 342
101	Moak's Card for Identifying Cows	357

CHAPTER I

GERMS IN THEIR GENERAL RELATIONS TO MILK

THE object of this book is to show the importance—nay, even necessity—of a clean milk production, and the practical methods by which it may be obtained. Heretofore milk has been regarded much in the same light as other articles of food, but it differs from them in many important respects. It is the only animal food which is commonly eaten in the raw state, and it forms the sole diet for human beings at an immature age, when they are least able to cope with the disorders which contaminated and dirty milk is liable to produce. Again—and this is the chief reason why milk needs especial care in its production—it always contains more or less germs, and, indeed, forms one of the most favorable foods on which germs grow.

The common idea of germs appears to be that they are chiefly important in being the cause of disease, and while some germs do produce disease—and occasionally those inhabiting milk which has not been properly cared for—yet they mainly interest the farmer on account of their powerful and enormous influence upon milk and its products. The chief aim of this book is to enforce on the farmer and dairyman this one fact, that the One Essential in producing and handling milk is CLEANLINESS, and cleanliness means in this connection freedom from germs, so far as this is possible. It would scarce be an exaggeration to say that all the trouble which arises

in the endeavor to secure good milk or milk-products results from the contamination of milk with undesirable germs. Thus the proper taste, odor, color, consistency and keeping qualities of milk depend upon its comparative freedom from undesirable germs. Conversely, the souring of milk and faults in odor, color, consistency and taste depend almost wholly upon the presence of one or more varieties of germs.

Moreover, the prevention of contamination of milk with miscellaneous germs is just as important in order to make the best products from milk, as it is to avoid disease in man. Thus the finest cream is only produced from milk in which germs are comparatively absent. Cream laden with miscellaneous germs has bad keeping qualities and often a faulty taste or odor. Most of the so-called faults of butter arise not from improper feeding of cows or from improper making or handling of butter, but from undesirable germs which infest it. Among some of the more common faults of butter are poor flavor, tallowy or oily butter, butter having a bitter, rotten or root-taste like turnips, rancid, mottled and moldy butter, and butter of unusual colors; all of these faults have been proved to be due to the contamination of butter with germs which existed in the milk.

While germs in milk produce changes in cheese which give rise to its proper consistency and flavor, yet it is only a certain type or types of germs which are desirable, and a general pollution of milk with germs of many kinds may wholly unfit milk for cheese making.

It is essential that milk should be pure when employed for condensing, and, although germs are destroyed in the process, this is much more readily accomplished if the milk is clean in the beginning and the keeping qualities will be much better. Above all, when milk is sold for general consumption it must be pure—comparatively germ-free—to be wholesome, to bring a good price, to keep, and to fall within the legal requirements which will soon become general throughout this country.

Heretofore, when milk was regarded in the same light as any other food, the law required simply that it should not be adulterated and that it should contain a quantity of food-constituents equivalent to the minimum standard in force. Now, however, it has come to be realized that of the two the cleanliness of the milk is an hundred-fold more important than its food value. While a milk poor in fat may mean a certain loss of nutriment to one using it, the contamination of milk with certain germs may be a matter of life and death to the consumer—particularly if an infant. The sooner the farmer and dairyman realize that the secret of success in the making of milk and milk-products is cleanliness—and by cleanliness we mean essentially methods to prevent the entrance of germs into milk—the better will it be for them and for everyone.

Germs, or, as they are more technically termed, bacteria, are the most minute forms of plant life we know. They occur in various shapes, but chiefly in the form of either rods, round cells or spirals. When seen through the microscope they present somewhat the appearance of minute lines, balls or cork-screws, according as they belong to one or the other of these three types. In masses of thousands they may be visible to the naked eye as specks like mold, but singly they can only be seen with a compound microscope magnifying more than 500 times. The most common of all varieties of germs in milk are those which cause it to sour—the lactic acid bacilli (the bacilli are the rod or shaped germs), and these are about 3-25,000 of an inch long and 1-25,000 of an inch broad. Germs grow on vegetable and animal matter, but not in the tissues or cells of living animals or vegetables, although they are found on all parts of them exposed to the air. Germs are, in fact, everywhere—in the air, in water, in soil, on the skin and in the digestive canal of animals and on the surface of plants and in dust. Professor Conn has found as many as 200 different kinds of germs in milk alone. Germs propagate by dividing into two equal parts—more usually—which form new

individuals. The time required for a germ to mature and form a new germ may not be more than twenty minutes.

GermS also multiply by spores—that is, small, round or egg-shaped bodies appear within the mature germ and these later break loose and develop, under favorable circumstances, into full-grown germS again. GermS which increase in this manner are much more difficult to kill, for in the spore stage they often defy prolonged heat, even at the boiling temperature, and also cold at or below freezing and dryness, as dust, in which they may exist for years. To show the possibilities in the way of multiplication, it has been calculated that a single germ, under favorable circumstances, may within twenty-four hours produce over sixteen millions of progeny.

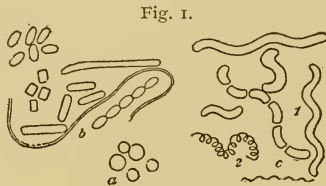

General shape of bacteria. a, spheres; b, rods; c, spirals. (After Conn.)

GermS, however, depend upon certain conditions for their growth; otherwise they would crowd all other life off the globe. Besides organic matter to feed on, the chief circumstances limiting their existence are heat and moisture. GermS usually do not grow at a temperature below 39° or above 140° F. This does not apply to the growth of bacteria in ice cream, as germS may multiply five-fold within three days in ice cream kept at a temperature five degrees below zero Fahrenheit. Milk kept frozen at 29° – 31° F., containing but a few hundred bacilli to the cubic centimeter at the beginning, may contain hundreds of millions of germS when kept in cold storage at this temperature after 5 or 6 weeks (Pennington). The milk at the end of this period is not altered in odor, taste or in any way to show the tremendous germ-contamination.

It does not even curd on heating. The proteids of the milk are, however, transformed into cleavage products owing to digestion of the casein by the peptonizing or digestive action of the bacteria.

Such decomposed milk may be harmful or actually poisonous, and all milk kept sweet over long periods by cold alone is to be regarded as unfit for food—especially for infants.

The number of germs developing in milk at the freezing temperature is considerably greater than in milk kept at room or body temperatures after the elapse of several weeks. Freezing, therefore, does not necessarily destroy germs—as, for instance, the germs of typhoid fever have remained alive in ice for a period of three months—but this temperature retards their growth (see p. 6) and many kinds of germs are killed by it. Ice water is therefore comparatively free from germs. The most favorable temperature for the growth of disease germs is that of the animal body—from 98° F. to 103° F.—while most other germs multiply most readily between the temperatures of 59° F. and 77° F.

This knowledge is of the greatest importance in the care of milk and teaches us that the chief essential consists in cooling it immediately to a low temperature (40° F. to 50° F.) and keeping it at this temperature thereafter till consumed. The number of germs in milk is always estimated as that number contained in a cubic centimeter of milk. A cubic centimeter represents a cube holding a quantity of liquid equivalent to about one-quarter of a teaspoonful, or sixteen drops of water. If very clean milk is kept below 50° F. for 24 hours there is not only not an increase but generally a decrease in the number of germs, and the same usually holds good for very clean milk kept 36 hours below 45° F. The initial decrease in the number of germs in new milk is due to a feeble and variable germ-destroying substance present in fresh milk. Immediate cooling does not affect the germicidal substance, but heating milk may destroy it (see p. 10). The bactericidal body in milk does not lower the number of bacteria in milk which is kept at high temperatures—

over 60° F. The germicidal action disappears spontaneously in old milk. After 36 hours, when milk is kept at 40° F., there is an increase in the number of germs. Dr. Park found in a sample of milk containing only 3,000 germs in the cubic centimeter, that after 24 hours at 42° F. it contained 2,600 germs; after 48 hours 3,600 germs; and after 96 hours 500,000 germs to the cubic centimeter. The bacteria in reasonably clean milk (12,000 to 25,000 per c.c.) will multiply some fourfold at 50° F. in 24 hours; and at about the same rate when kept at 46° F. for 36 hours. The number of germs in milk kept at 32° F. lessens from day to day for a number of days, then increases.

When milk is kept at higher temperatures the germs multiply rapidly and it sours and deteriorates correspondingly. It has been shown that very clean milk (containing but 3,000 germs to the cubic centimeter), if kept for 24 hours at 60° F., held 180,000 germs; if kept at 86° F. for 24 hours it contained 1,400,000 germs; and at 94° F. the germs multiplied so tremendously that at the end of 24 hours the same milk contained 25 billion germs per cubic centimeter.

All germs require some moisture in order that they may actually grow, but they may exist in large quantities—for a longer or shorter time—in dust. Some require air for their existence, others do not.

Sunlight is one of the most powerful enemies of germs, since few will thrive in sunlight, especially in the presence of fresh air. This explains the value of sunning dairy utensils and of permitting the sunlight to enter freely into the barn and dairy. Some germs grow more readily in substances having an alkaline or neutral reaction; others, as those which cause milk to sour, flourish in an acid medium, providing the acidity is not too great.

The most potent factors in destroying germs are intense heat and cold, sunlight and chemicals. A temperature varying from 140° to 158° F. will kill most germs—if continued long enough or

repeated at frequent intervals. Milk treated by continued, intermittent heating at 140° F. has been kept for years without changing, owing to the destruction of germs (and ferments) in it. As the time required for the destruction of germs at this temperature is too great for commercial purposes, temperatures ranging from 160° to 176° F. are usually applied for either killing or checking the development of germs in milk. Heating milk below the boiling point with this object in view is called technically pasteurization, after the great originator of the process. If properly done, pasteurization kills most of the germs in milk (95 to 98% of all bacteria, including those which cause disease in the human most commonly, *i. e.*, the miscellaneous and undetermined germs which induce diarrheal diseases in infants, and the special germs of typhoid and scarlet fever, Malta fever, tuberculosis, and diphtheria), and this is the best way to obviate the dangers of dirty milk for human consumption—more particularly in the case of infants. The spores of germs—the immature forms from which germs develop—are not killed by pasteurization or even by boiling milk; a still higher temperature is required. Most milk contains some spore-bearing germs and so cannot be made absolutely germ-free by pasteurization or boiling. Boiling milk alters its taste and chemical composition, and renders it somewhat less digestible. There are certain drawbacks to pasteurization, however. If the milk has been kept long before heating, poisons may form in it which the heat will not destroy.

Our knowledge concerning these poisons (or, more technically, toxins) resulting from the growth of germs is very slight. That is, concerning the varieties of germs which may produce toxins in milk, and the harm which they do, and the effect of heat upon them. It is generally conceded, however, that it is impossible to make an old and dirty milk harmless by heating it, and that myriads of dead bodies of germs and their products are sometimes poisonous to infants—even after the milk containing them has been pasteurized. Milk, then, which contains a large number of germs, or an acidity

over 0.2%, is unfit for pasteurization. A high acidity generally means an excess of spore-bearing germs which are not killed by pasteurization. These induce putrefactive changes in milk with the production of poisons or ptomaines from decomposition of the milk—not directly from the growth of germs. Milk and cream should, then, be pasteurized when fresh, since when old the spore-bearing germs are apt to be abundant. Commercial pasteurization is therefore more fitly done in the country at the creamery.

There are certain substances naturally present in cows' milk exactly resembling those which bring about the digestion of food in the stomach and bowels of man and animals. These chemical substances in milk or in the digestive organs are called ferments (or enzymes). They appear to aid the digestibility of milk, particularly in infants, and are destroyed by heating milk over 150° F., or at a lower temperature if the milk is repeatedly heated. These natural ferments in milk one must keep distinct in the mind from those ferments formed by germs accidentally contaminating milk (see below). It is generally accepted, however, that babies will not thrive so well on pasteurized milk for long periods, as on clean, unheated milk, and occasionally develop malnutrition, anemia, rickets and scurvy. The last may be prevented by feeding infants one tablespoonful of orange juice twice daily. It is known that scurvy in infants sometimes occurs in infants fed on breast milk and on raw cows' milk. I have had a case in my own practice in a breast-fed baby. The milk was very low in fat (1.55%) and probably also in proteids.

Moreover, it has been contended that pasteurized milk is more digestible than unheated milk, since heating milk prevents the fat globules from running together, and since heating lessens the curdling of milk in the stomach by rennin. The same effect is seen outside the body in the action of rennet on raw and heated milk. Finally, there are experiments that seem to show that pasteurized milk is absorbed more readily than raw milk from the bowels.

It may be positively affirmed, however, that American physicians having most experience and knowledge of feeding babies are generally agreed that infants thrive best on clean, unheated milk.

The whole question of the comparative value of raw and pasteurized milk for infants' food is still undecided. In either case it is equally imperative that the milk be as clean as possible.

The "ferments" of milk aid digestion of milk, and even that of other food taken with the milk. Different ferments occur in the milk of different animals. Similar ferments occur in the milk of women and bitches; also there are like ferments in the milk of cows and goats.

Besides the ferments in fresh milk, there is also a body which is destructive to germs.* It is probable that both the ferments and this germicidal substance disappear spontaneously in 24 hours, and both are weakened or destroyed by high degrees of heat. The chief ferments in cows' milk are the following: 1. *Galactase*. This is a proteolytic ferment, or that digesting proteids, as casein of milk. Other proteids in the stomach may be digested to some slight extent by it in new milk. Galactase occurs in the milk of most animals and is not destroyed except by heat near the boiling point. Galactase consists of galactase proper and two other ferments (catalase and peroxidase), which do not affect the digestion of milk. 2. *Lipase*. This is a fat-splitting or fat digesting ferment. It is weakened by a temperature of 145° F., and destroyed by 149° F. 3. *Lactokinase*. This digests proteids similarly to galactase, but acts especially in the small intestines of animals consuming milk. It is destroyed by

* It should be stated, however, that Stocking denies that there is any germicidal substance in milk. From his experiments he concludes that the primary decrease in bacterial content in fresh milk is simply due to dying out of those varieties of bacteria which do not readily flourish in milk. If bacteria—which find in milk their natural habitat—predominate in fresh milk, then there is a constant increase from the time the milk is drawn. These bacteria natural to milk include the *B. lactis acidi* and *B. lactis aerogenes*.

heat from 163° F. to 167° F. The germ-destroying substance is weakened by 149° F., acting for half an hour.

Now, the important point lies in the fact that the disease germs which occasionally are present in milk (germs of typhoid and scarlet fever, diphtheria, tuberculosis, cholera and streptococci and staphylococci) may be killed by a comparatively low degree of heat (140° F.) without destruction of either the ferments or the germ destroying substance.

Then there may be the poisons, spoken of above, to be considered. Those arising in milk from germ growth (toxines) we have little knowledge of, but those we do know about (as the toxines of diphtheria and tetanus) are readily destroyed by a low degree of heat (140° F.) The poisons or ptomaines arising from the action of spore-bearing germs in causing putrefaction of old milk are found in pasteurized milk because heat does not kill these germs. From what has been said it would seem that the temperature of 140° F. is most suitable for heating milk intended for infant food. The time during which milk should be thus heated has been found (Freeman) to be 30 minutes in order to effectively kill most germs.

This, then, seems the best temperature and time for pasteurizing milk for infant food. Milk is more commonly pasteurized now at higher temperatures. To be effective in killing germs pasteurization should be done as follows: If milk is heated to 150° F., it should be maintained at this point for 20 minutes; if to 160° F., then it should be maintained for 15 minutes; if to 170° F., then it should be maintained for 10 minutes. As a matter of fact, most medical authorities have been in the habit of pasteurizing milk for infants at 150° F. to 160° F. for 20 minutes. Authorities differ somewhat as to the proper pasteurizing temperature. Pasteurizing at a low temperature (140° F.) is chiefly important for infants—not for adults. Park states that heating milk at the following points will kill typhoid, tubercle and other non-spore bearing organisms:—

For 10 minutes at 80° C. (176° F.).

For 15 minutes at 70° C. (158° F.).

For 1 minute at 70° C. kills 99% of tubercle bacilli (tuberculosis germs) and 95-98% of other non-spore bearing germs.

Rosenau finds milk heated to 60° C. (149° F.) for 20 minutes kills tubercle bacilli and Malta fever germs; for 10 minutes—dysentery bacilli; for 2 minutes—typhoid, diphtheria and cholera organisms.

“Ferments,” or enzymes, must be distinguished from germs (or living ferments), which are the most common causes of fermentation. Enzymes are chemical substances, but are derived from living cells.

Those related to milk are derived from three sources. 1. They may naturally exist in milk and are presumably secreted by the udder cells, as rennet is secreted by the stomach. The ferments just described belong to this class. 2. They may be produced by various germs contaminating milk (as the rennet-like ferment of certain germs; the liquefying ferments of liquefying or putrefactive bacteria). 3. The third class includes simply rennet obtained from the animal stomach and often added artificially to milk in cheese-making, etc.

There is, indeed, as much difference in practice as in theory regarding the comparative value of heated and raw milk for infant feeding—even in the case of certified milk. Thus in nine milk stations (see p. 173) supplying milk for babies in different cities of this country, under the best medical supervision, we find that the practice of four stations is to feed the certified milk raw as it comes from the dairy; in three the certified milk is wholly pasteurized; and in two stations the certified milk is under some circumstances pasteurized (as in hot weather). It remains to be seen whether milk heated to 140° F. will be deficient in any properties of fresh, unheated milk.

Obstinate constipation is sometimes seen in animals and children living on milk pasteurized at the higher temperatures. In the

public use of pasteurized milk* there arises the difficulty of determining its true condition by ordinary tests at our command. Thus it may not show acidity when old (as lactic acid germs are most readily killed by heat), nor may it be altered in appearance or taste, and yet be swarming with deleterious germs—if kept for some time at low temperature.

These last remarks apply particularly to pasteurized milk which has been insufficiently heated (not uncommonly so in commerce as regards time of heating), or which has been placed in dirty or unsealed containers, or to that which has not been rapidly cooled, or to that which was too dirty and germ-laden before heating, or to milk kept too long after heating. Therefore it will be seen that pasteurization will not make a dirty or old milk harmless, and that the same care in cooling, in the use of clean utensils, in avoidance of contamination in handling, together with the necessity for its speedy consumption, are as essential as with clean, unheated milk.

Against all objections to pasteurized milk the one salient, undeniable fact stands out, viz., that properly pasteurized milk is a comparatively safe food, whereas unheated milk is not. This follows because occasionally in the most carefully handled certified milk contamination with contagious disease may occur, while in ordinary market milk not only is this danger present, but that of tuberculosis germs, and the many miscellaneous bacteria arising from manure, filth, impure water and utensils and disease of cows. But since the chance of harm from certified milk is slight, and because of objections noted regarding pasteurized milk generally, Melvin has offered the following solution. He advises that all market milk, except such as is “certified” or “inspected,” be subjected to compulsory pasteurization under the supervision and control of health authorities (see p. 186)

* For municipal regulations of pasteurized milk see p. 216.

The simplest method of home pasteurization consists in bringing water to the boiling point in the outer part of a double boiler. As much water should be used as can be contained in the outer part when the inner part of the double boiler is in place. When the water boils, the outer part of the double boiler is taken off the fire and placed upon a piece of board. Then into the inner part is placed the milk and the inner part is inserted into the outer part of the double boiler and is covered. After the milk has been in the boiler 20 minutes the inner part is placed in cold water. It should then be put on ice and covered. Or water may be brought to the boiling point in a pot having a close-fitting cover. Then the pot is at once removed from the stove and placed on a board. The individual nursing bottles, having been previously filled with milk, are now placed in the pot of boiling water, which is covered. The water should be of sufficient depth to reach the same level without the bottles as the milk reaches within them. The bottles are kept in the hot water for 20 minutes and then cooled in cold water and kept on ice. By either method of pasteurizing the milk is brought to about 165° F. Freeman's pasteurizer is to be commended for more accurate results.

Home pasteurization is far preferable to commercial pasteurization, as the latter is at present not at all to be relied upon. All milk, not certified or equivalent to certified milk, should be pasteurized for use by infants or invalids. Even certified milk is often pasteurized when employed for babies and the sick. In the summer months this may be advisable and in New York at the Straus milk stations certified milk is pasteurized the year round.

As I have observed, in pasteurization done on a large scale for market purposes in Seattle, the result has been a farce other than it enabled the milkman to keep the milk for perhaps twenty-four hours longer than it would have otherwise kept sweet. The pasteurization of the market milk is done for one to three minutes in machines of the continuous type. The pasteurizers having a large chamber, in

which the milk may be retained for the required time, at the proper temperature, are preferable.

Almost all the commercial pasteurizers are of the continuous type, for convenience in handling large quantities of milk, and are made to allow milk to flow through them as quickly as possible, after the temperature of the milk has been raised to 155° F., 165° F., or thereabouts. A discontinuous pasteurizer, in which the milk is heated by a hot water jacket while it is kept in motion by rotating arms or other device, is to be preferred because the milk may be kept in the machine for the proper time after it has reached the desired temperature.

When milk is to be used directly for food it is better that it be pasteurized in sterile bottles so that it may not become afterward contaminated by handling.

The bottles are first cleaned and sterilized, and filled and capped, and then placed in a steam sterilizer; or are immersed to their necks in a water bath heated by steam. All milk should be rapidly cooled after pasteurization. If in bottles, the water about the bottles is quickly reduced in temperature. If milk is heated and unstirred in open vessels a scum will form on the surface in which the germs of tuberculosis may not be killed by ordinary pasteurization temperature and time. The cost of pasteurization is said to be from 1/10 to 1/2 cent per quart. Rapid alteration in temperature is particularly effective in killing bacteria. So that, in the short pasteurization done commercially, rapid cooling is of the greatest import. Rapid cooling also destroys the cooked taste of milk. Pasteurized milk should not only be immediately cooled to 40° F., after heating, but should be kept at that temperature in closed, sterilized bottles or cans for several hours before it is delivered—to still further check the growth of bacilli.

In order that a pasteurizer shall fulfil the scientific requirements it must be able to heat the entire amount of milk it contains (including the froth) to the proper temperature, and maintain the

milk at this temperature for the time suitable to the temperature. Also the machine must work reliably and be easy to clean. Commercial pasteurizers should also have an automatic, temperature-regulating device which is self-registering, and this is now demanded by Boards of Health (p. 217).

Imperfect pasteurization prevents milk from souring quickly because the germs which cause milk to sour are those most readily succumbing to heat (since they are generally not spore-bearing germs). The general effect of imperfect pasteurization is simply to check—for a longer or shorter time—the growth of germs. They are retarded in their development, not killed. Disease germs may not be wholly destroyed in the process. Experiments which I have conducted with the pasteurized milk of the general market (in cans) showed that while containing but 15,000 germs to the cubic centimeter, soon after emerging from the pasteurizer on the delivery wagon, in twenty-four hours the same milk contained several million germs to the cubic centimeter. Drs. Bergey and Pennington found much the same result in Philadelphia; that raw and recently pasteurized milk contained respectively 1,260 and 12 bacteria, but, at the end of 72 hours, the numbers were 17,000,000 and 148,000,000 germs. Also the harmless lactic acid germs of raw milk are killed by heat, and the more dangerous germs from dirty bottles, corks and dust contaminate the improperly pasteurized milk. A commercial pasteurizer which fulfils the scientific requirements for heating milk, *i. e.*, one in which milk may be heated to a given temperature and held at that point for a given time, is the Willmann Perfect Pasteurizer made by the Dairy Machinery and Construction Co., of Shelton, Conn. In this machine the milk is first heated to 145° F. and then passes into an automatic holding machine, where it is maintained at this temperature by an automatic device for 30 minutes, when it is discharged automatically back into the original regenerative pasteurizer and thence on to a cooler to be cooled to 38° or 40° F. If pasteurization is done thoroughly the lactic acid bacilli (sour

milk germs) are destroyed and so the milk does not sour but putrefies when it ages.

Pasteurization prevents milk from being properly curdled by rennet and so unfits milk for cheese-making. Cheese is, however, now being made from pasteurized milk to which is added a "starter." Pasteurized milk or cream may be used to advantage for butter-making when the lactic acid germs are added in the form of sour milk, known as a "starter," which will be described later. Since butter frequently contains tubercle bacilli (tuberculosis germs) it should always be made from cream derived from tuberculosis-free cows or else cream should be properly pasteurized. If we must have dirty milk, pasteurization is the best remedy for this unhappy state of affairs, but it may well prove undesirable to thus remove the incentive to dairymen to produce clean milk. If done at all for the market, it should be done thoroughly (see pp. 217-19), followed by rapid cooling.* If milk is not cooled down to allow point after pasteurization, spores will develop which have escaped destruction on account of their great resistance to heat, and these will result in germs which, while not souring milk, act on the casein to cause it to curdle and perhaps become poisonous and putrid. In Europe pasteurization of milk is much more common than in this country, since ice is in less common use. In Denmark it is required by law, so that tuberculosis may not be spread when skim milk and buttermilk are returned from the creameries and fed to calves and pigs. This custom should be imitated in the United States, since the young stock are not only protected from disease, but the keeping quality of the skim milk is so much improved. A higher temperature than 165° F. gives the milk a boiled taste and alters its composition to some extent. Steam or boiling water are used to destroy germs in or on dairy utensils.

* Pasteurized milk which is sold for general consumption should be always marked as such, in order that infants shall not be harmed by its use. (See p. 187.)

Chemicals find little use as germ-destroyers in a properly conducted dairy or farm. They may be employed to some extent in the barn (as lime scattered on the floor), or in case milk products become faulty through some contamination with special germs in the stable or dairy, and in case the stable has been inhabited by cows having tuberculosis, when general disinfection is in order (see p. 346). Various preservatives under the trade names of Freezine, Iceline, Preservaline, Milk Sweet (all containing from two to five per cent. of formaldehyde), and others containing boric acid, as Dry Antiseptic, Preserving Salts, "A" Preservaline, Cream Albuminoid, Patent "M" Preservaline and Ozone Antiseptic Compound, are employed to keep milk from souring without the use of ice or cleanliness by killing or checking the growth of germs in milk. Their use is contrary to law and detrimental to the consumer's health, especially when employed, as they usually are, in a careless way, without regard to what the effect of a considerable amount of the chemical might be. Thus the following instance is related in the Year Book of the Department of Agriculture for 1900 of a case where a preserving fluid was first added to the milk by the farmer, then by the collector of the milk, again by the wholesale dealer, and finally the fourth dose by the retail dealer.

If it were impossible to produce clean milk or to preserve it with ice, and if preservatives could be used properly in a harmless dose, their employment might be permitted, but such is not the case.

Significance of Germs in Milk

The growth of large numbers of germs in milk causes it to deteriorate because they remove nutriment or alter the milk chemically and thus lessen its food-value. Ordinary market milk, which is overrun with germs, loses much of its value as food after it is twenty-four hours old. The ideal result would be reached if milk could be withdrawn from the cow absolutely free from germs. This might be possible if germs did not enter the udder in the

air through the opening in the teat and find their way into the cavity or milk-cistern in the lower part of the udder. Among the more common germs found in the first or fore milk are the streptococci. Streptococci are those germs which are frequently responsible for various forms of inflammation in man and animals, and are also found in milk withdrawn from inflamed udders of cows affected with garget. That the streptococci ordinarily present in the teats of healthy cows are identical in appearance with the disease-producing streptococci is now known, but they are present in the cleanest milk, as they naturally enter the teats and milk cistern from the outer air. For this reason the fore milk is rejected by those producing clean milk.

Disease-producing streptococci are perhaps among the most important of the germs causing serious forms of infantile diarrhœas. Therefore when streptococci (with leucocytes) are present in excess the milk should be condemned for food (see p. 250). As the milking proceeds the germs in the milk-cistern and teat are washed away so that the latter part of the milk withdrawn is often absolutely free from germs until contaminated with the outside air. Occasionally germs may persist in milk throughout milking, and the strippings may contain as many as 500 germs to the cubic centimeter. If the latter part of the milk is withdrawn through an absolutely clean milking tube into an absolutely clean bottle, it will often be wholly without germs, and may keep sweet for months or years if it does not come in contact with the air. Such painstaking cleanliness as is necessary to make this experiment successful, is not of course practicable in actual dairy work, since it is not economically possible to throw away a larger part of the milk nor to withdraw milk so that it will not come in contact with air.* Therefore, under any ordinary conditions a certain number of germs must inevitably be present in the cleanest milk—perhaps 200 to 4,000 as the least number to the cubic centimeter.†

* Since writing the above the use of the milking machine (see Appendix) makes withdrawal of milk without exposure to air practicable.

† The average contamination of milk within the udder amounts to 500 bacteria per c.c. for all the milk from one milking; while there are, according to Conn, 6,900 bacteria on the average in the foremilk.

Then, if the milk is immediately cooled to 40° F. and retained at this temperature, the number of germs will lessen until it is thirty-six hours old.

The presence of many thousand germs to the cubic centimeter in milk freshly withdrawn indicates filthiness of the cow, milker or surroundings. This is especially so if the germs are of the putrefactive or liquefying type (see p. 23).

The existence of a great variety of germs in milk several hours old signifies contamination of the milk with filth also, because in clean milk only one kind of germs (lactic acid bacilli) are found very numerous after many hours.

While the mere fact that milk contains a vast number of germs is not a sure proof of its unwholesomeness—because the commonest germs in milk are harmless and because milk may contain but a few germs and these may be the cause of dangerous disease in man—yet the estimation of the number of germs in milk is to-day the best method we possess for determining its purity.

Ordinary market milk contains as many germs as sewage, and unusually dirty milk contains more germs than sewage was ever known to hold. This is, however, not at all a fair comparison, for while sewage is likely to contain all sorts of germs of disease, the germs in dirty milk are mostly not disease-germs.

We may consider the influence of germs in milk under two heads: 1. The effect of germs on milk and its products. 2. The influence of germs in milk on the consumer.

1. *The Effects of Germs on Milk and Its Products.*—All fermentation and putrefaction or rotting, anywhere and of anything, are usually due to germs. The changes wrought in substances by the “ferments” or chemical bodies—either produced by germs in milk or secreted in milk—and by the ferments in the digestive juices of animals, must also be included under the head of fermentation.

Germs are the great disintegrating agencies in the world;

they tend to break up complex, natural constituents in milk and its products into simpler bodies. The commonest germs in milk—as we have noted—are those causing souring of milk; they are invariably present and are about the only kind existing in very clean milk. They act to ferment or change the natural sugar of milk into an acid (lactic acid), and if they occur in large numbers a few hours after milking it is a sign that the milk has not been properly cooled and will sour early. Lactic acid germs, or those producing souring of milk, besides being the most common, are of most importance in their influence on milk and its products. They exist in very small numbers in milk soon after leaving the cow, but as they grow more readily than all other germs in milk at favorable temperatures (above 50° and better over 70° F.), they often constitute almost 50% of all the germs in twenty-four hours. While, after this time, they gradually crowd out the different varieties of competing germs until they produce so much acid that the milk or cream sours and curdles, and they have multiplied so rapidly and have made the milk so unfavorable for other germs that they form from 90 to 99% of all the germs present. This is a most favorable occurrence, because the flavor of most butter and cheese is chiefly dependent on the action of the lactic acid germs, and in their growth they protect the milk from the action of miscellaneous germs which would spoil these products.

Even to man the growth of the lactic acid germs is a favorable happening, as they are not harmful to adults in themselves and tend to check the development of other harmful germs in the digestive canal. Indeed Metchnikoff, perhaps the most celebrated living authority on the action of germs on the body, believes that lactic acid germs in sour milk constitute one of the best agencies for prolonging life. The acidity of sour milk is, however, harmful to children and may cause vomiting, etc. As we have pointed out, heating milk to 155° or 165° F. readily kills the lactic acid germs. Therefore such milk does not sour, but is changed by the action of

Other harmful germs so that it rots or putrefies when old. A low temperature (40° F.) also retards the development of the lactic acid germs and they are killed when the milk or cream becomes very sour (when the formation of lactic acid reaches 0.8-2.0 per cent), by means of the lactic acid they themselves produce. The action of these lactic acid germs is taken advantage of in the ripening of cream for butter by adding them in great numbers, either by the use of sour cream or milk, or by laboratory methods by which they can be obtained in pure culture—that is, free from admixture with other varieties of germs (see page 59). Lactic acid germs are not found in milk when it leaves the udder, but enter the milk when it is exposed to air. They are thought to reside on the skin of the cow, in dust, in the air or surroundings of the barn. But milk utensils—unless sterilized by steam or boiling water—are the chief means of supplying milk with lactic acid germs. This happens because sour milk germs lurk in the corners and rough surfaces and crevices of milk vessels. So, from the milk pail to the shipping can or milk bottle, each and every utensil adds its quota of lactic acid germs—unless the utensils have been thoroughly washed and heated for some time to the boiling point. Ordinary market milk at 50° F. sours in 120 hours; at 60° F. it sours in 66 hours; at 98° it sours in 16 to 18 hours.

There are two types of lactic acid germs: (1) The more common (*B. lactis acidii* or *Streptococcus lacticus* *) constitutes on the average about 90% of all the germs in milk. It grows best without air (anaerobic), and so milk sours best in deep vessels. (2) The less common type of lactic acid germ is that which causes gassy milk and cheese (*B. lactis aerogenes*) and is derived also from the dirt of the cow and does not come from the udder. Certain germs capable of producing disease in man also sour milk.

Of these the colon bacillus is derived from manure of the cow. And the germs causing inflammation of the udder (streptococci) in

* *Streptococcus lacticus* rightly forms a third group of lactic acid bacteria. It is the commonest organism souring milk, it differs from lactic acid bacteria (which are oval, in pairs or short chains) in appearance and is indistinguishable from disease-producing streptococci (*S. pyogenes*) but is harmless to man occurring in uncontaminated milk from healthy cows.

the cow may act as lactic acid germs and, on entering milk, may cause disease in man drinking it.

Altogether some 100 varieties of germs may lead to lactic acid fermentation and souring of milk. In general it may be said that when 80 to 90% of the germs in milk belong to the more common type of lactic acid germs the milk is wholesome—even if germs are in great numbers. If there are less than 20% of lactic acid germs in such milk it should be regarded as unfit food (Conn). Sour milk becomes covered in time by moulds (*Oidium lactis*) and colored spots produced by various bacteria and fungi.

At the Paris exposition of 1900 there was an exhibit of dairy products, under care of Major Alford, of the U. S. Department of Agriculture, which consisted of fresh milk and cream shipped from Illinois, New Jersey and New York in hot weather (July). Coming some 3,000 to 4,000 miles, the cream and milk were perfectly sweet a fortnight after being bottled, while the only other competitor was the French with a local supply which did not keep a day after reaching the grounds. In the Chicago National Dairy Show in 1906 a sample of cream shipped over 1,000 miles was still sweet at the end of 7 weeks. Cleanliness and cold were the only methods used in so wonderfully preserving this milk.

If milk is very dirty, however, it is not safe to keep it too long with ice, even if it does not sour and is unaltered in taste, as various sorts of harmful germs may develop at a low temperature. Thus, milk containing, soon after milking, some 800,000 germs to the cubic centimeter, after four days at 41° F. contained almost five million germs and became sour. At the end of ten days this same milk contained over 400 million germs, or over ten times the number of germs in the same milk kept the same time at 59° F.* The milk kept at a higher temperature soured more quickly and the acid destroyed many of the germs in the process.

* Swithinbank & Newman.

The kind of germs which will grow in milk depends on the temperature of the milk. Below 60° F. miscellaneous germs grow, but those which sour milk do not flourish. Therefore in dirty milk which kept for some days below 50° F. the miscellaneous germs may be abundant. These, or the poisons they produce, may cause disease in the human being—chiefly nausea and vomiting, and cholera infantum. The harmless lactic acid germs flourish at room temperature (60°—70° F.). Comprising less than 1% often in new milk, in 24 hours at room temperature they may reach 50%, and in 48 hours 95% of all the germs in the milk. At this time the milk sours, the acid having killed all the other germs.

At temperatures between 80° and 100° F. various different kinds of germs may predominate, but often the germs which lead to formation of gas in milk and cheese are in most abundance (*B. lactis aerogenes*).

It will thus be noted that sweet milk may be much more harmful to health than sour milk, *i. e.*, if it was contaminated and has been kept sweet by means of a low temperature.

There is a large class of germs known as putrefactive germs because they produce changes in milk which are akin to rotting of meat. If these continue to develop long enough they may impart a bad odor to milk or its products and are likely to induce diarrhoeal diseases in children.

Among the more common putrefactive bacteria which work harm to milk are the "liquefiers." They enter milk in manure and filth and thus to a considerable degree indicate contamination of milk with filth.

The liquefiers may at first cause "sweet curdling" in milk from the action of a rennet-like ferment they produce. Later—or sometimes immediately—the liquefiers alter and dissolve the casein of milk by means of another ferment (casease) which digests the casein. The milk then becomes clear as water or variously colored and has a putrid odor.

The liquefiers also liquefy the substance on which germs are commonly grown in the laboratory, *i. e.*, gelatine; hence their name.

The putrefactive germs or liquefiers may amount to 20 or 50% of the germs present in milk at the end of 24 hours (Conn), but from this time on they are commonly crowded out by growth of the lactic acid bacteria and gradually disappear.

There are a great number of germs in milk which apparently have no effect upon its character and also are not harmful to the consumer. It is practically impossible to discover the germs of special diseases in milk with any certainty, so that besides recognizing the chief types of germs—the lactic acid germs, the putrefactive germs, and miscellaneous germs whose action is unknown to us—the best that can be done at present is to estimate the number of germs in milk per cubic centimeter. Large numbers of miscellaneous and putrefactive germs signify that the milk is contaminated with filth and is most dangerous. Large numbers of lactic acid germs indicate that the milk has not been kept cool enough or is old. Freedom from any considerable number of germs is a pretty certain sign that the milk has been drawn from the cow and handled in a cleanly manner; has been properly cooled and is likely to be uncontaminated with disease-germs. This is the justification of cities which require that milk shall not contain more than a specified number of germs (bacteria) to the cubic centimeter.

Thus the law in force in Boston requires that milk sold in that city shall not contain more than 500,000 germs to the cubic centimeter.

It has generally been admitted that it is difficult to obtain any large supply of milk which shall certainly contain less than 10,000 germs to the cubic centimeter. In various parts of the United States milk of such purity is now sold and is often called "Certified Milk." The name "Certified Milk" originated with Henry L. Coit, M.D. He established a commission of medical men in Newark, N. J., in 1893, who made an agreement with a dairyman of Caldwell, N. J.,

to furnish milk subject to their requirements and inspection which should be known as "Certified Milk" when approved by the commission.

Certified milk is that produced under a legal contract between a medical milk commission and a dairyman to conform to certain recognized requirements. The name was registered in U. S. Patent Office in 1904 with the understanding that it should be used by medical milk commissions but not by dairymen not supplying milk to medical milk commissions.

New York State has passed a law preventing the use of the word certified milk except by permission of medical commissions formed by county medical societies which are organized and chartered by the State Medical Society. Similar laws should be passed in other states and offenders should be prosecuted.

Examinations of certified milk should be made by chemist, bacteriologist and veterinarian (stock and stabling, etc.) twice monthly and members of commission once monthly.*

Any person who pretends to produce clean milk must submit to the germ standard, as this is the best means of estimating purity which we now possess. Exactly what that standard should be has, however, not been generally agreed upon. It is not unusual to find 10,000 germs as the maximum number per cubic centimeter permitted in certain localities for certified milk. The standard of Albany for certified milk has been 80,000; for Rochester and New York City, 30,000; for Philadelphia and Milwaukee, 10,000. The U. S. Agricultural Department standard is 10,000, and this should now be considered the maximum, as it was originally established by Coit. It is perfectly possible to produce milk which shall not contain more than a few hundred, or, at most, not more than 2,000 to 4,000 germs to the cubic centimeter without great expense, if every precaution to secure cleanliness be observed in milking and handling the milk. At Newburgh, N. Y., certified milk has been

* For blank forms to be used in these examinations, see p. 204.

produced from a herd of 100 grade Jersey and Guernseys which has had a bacterial count below 1,000 for one year and an average of 150 bacteria for 15 successive weeks from samples taken at random in the city.

The usual contamination of milk with germs may be judged by the following figures with the understanding that great improvement is taking place owing to the interest which has been shown in the matter of obtaining a pure milk supply in recent years by physicians and others. In Boston, during the spring of 1890, 57 samples of milk showed an average of 2,355,500 germs in the better class milk, and of 4,557,000 germs in grocery milk. In winter the growth of germs is considerably lessened by the colder temperature and this is somewhat counterbalanced by the filthier conditions of the barn floors, air and of the animals. On the whole, winter milk is, however, much freer from germs. The New York County Medical Society issue a certificate of inspection to farmers who will follow their directions for producing a second-grade, pure milk which shall not average over 100,000 germs from May to October, and not over 60,000 germs from October to May. In Seattle I found in twenty-eight examinations of different samples of milk on as many days in May and June, that sixteen samples averaged over 3,000,000 germs, and twelve samples less than 1,000,000 germs per cubic centimeter. The examination of these milk samples was done when the milk was fifteen to thirty-six hours old, on the way to the consumer's house, being taken from the delivery wagons or on arrival of the milk train.

A great many conditions may alter the number of germs in milk if milk is not produced and handled in a proper manner. Time and temperature are the two most important factors upon which the growth of germs depends—and the greatest of these is temperature. The milk from one farm examined at the same hour on two consecutive days averaged 1,150,000 germs on the first day—which was warm for May—and 48,000 germs the following day,

which was cold and rainy. The great increase of germs when milk is kept at improper temperatures, we have already noticed, the number of germs in such milk depending entirely upon its age. To show the effect of dust and unclean utensils on milk I may cite the following: A sample of pasteurized milk, taken from a delivery wagon and examined by the writer, contained seven million germs, while from the same wagon was also taken a sample of the same milk put into sealed milk bottles which contained but 24,000 germs to the cubic centimeter. The first sample was taken from a large can which was frequently opened to pour out small quantities for consumers and very likely the can was unclean before the milk was put into it.

After the milk is withdrawn from the cow the number of germs in it generally diminishes for a longer or shorter time, and after this period the number rapidly increases. Thus at forty degrees the number of germs may not be greater in thirty or forty hours than it was when the milk was first withdrawn. At a higher temperature the germs begin to multiply in the milk as soon as the third hour after it has left the cow. Each variety of germ has a special temperature at which it flourishes to best advantage. The lactic acid germs grow more favorably at comparatively high temperatures—from 70° to 90° F., or even higher.

There are certain special germs—not all of which have been studied—which produce special faults, or, as they have been called, diseases of milk.

Thus the butyric acid germs develop that acid by the splitting up the fat in rancid butter. Yellow, red, blue, brown and green milk are rarely seen and the particular coloration is due to changes produced in the milk by special germs. A turnip taste is often given milk by a particular germ (*B. fœtidus lactis*). So also are slimy milk, bitter, stringy and soapy milk, owing to special germ-development and its effect on milk. It is thought that slimy milk may be caused by cows eating the leaves of the plant, *Pinguicula vulgaris*, since placing the leaves in milk will induce this condition.

Bitter milk may, however, be produced by other causes than the growth of germs, as by certain foods which the cow may eat (lupines, ragweed, wormwood, cabbages, raw swedish turnips), or as seen in milk during late lactation or in garget. In these cases the milk is bitter soon after it leaves the cow; but bitterness induced by the growth of germs is usually not seen except in old milk.

Red milk may be due to contamination with blood, following injury to the udder or teats. Red milk is said to occur owing to cows eating large amounts of sedges, rushes, madder root, alkanet, field horsetail, meadow saffron, and knot grass.

Aside from slimy milk caused by pus escaping from inflamed udders, a special germ (*B. lactis viscosus*) is commonly the source of this condition. This germ exists chiefly in water and in dust. To prevent slimy milk one must avoid contamination of the milk with unboiled water or with dust. Thus all milk utensils (including strainer cloths) must be thoroughly sterilized by boiling or by steam in a sterilizer.

Tanks containing water for cooling cans must be sterilized by using a solution of bichromate of potash (1 ounce to the cubic foot of water). Cans filled with milk may be kept in this solution, providing it is not spilled into the milk. Not a drop of unboiled water should be permitted to drop into milk or milk utensils. Floors of rooms in which milk is kept may be disinfected by 5% sulphuric acid solution. Milk utensils must be kept inverted and covered when not in use.

Cows should not be allowed to soil their udders by wading in mud and water. Slimy milk is not harmful but very distasteful.

This whole book is chiefly devoted to the influence of germs on milk, in one way or another, and further reference to the subject will be found under the special topics considered.

2. *Action of Germs in Milk Upon the Consumer.*—As we have already intimated, germs do not enter milk during its forma-

tion in the udder of the cow, in normal conditions, but only gain entrance to milk through the medium of the air when the milk flows into the receptacle or cistern which communicates with the air through the opening in the teat. We showed that if the milk cistern was washed out clean and that if then a milking tube was introduced into the teat it was possible to secure milk free from germs altogether and which would therefore remain sweet indefinitely if kept in a sealed flask. If the cow is suffering from a germ-disease it is possible for the germs to get into the milk, during its formation in the udder, from the blood of the animal, if it has a general disease; or, what is still more likely, if there is disease of the udder itself, the germs may find their way into the milk directly from the diseased parts. While, in the case of most general infectious or germ diseases of cows, the germs will not escape in the milk yet the toxins or poisons produced by these germs may so escape. Inflammation of the udder may be caused by various germs, of which the germ of tuberculosis is one and perhaps the most dangerous. This germ is found in milk, then, more frequently when tuberculosis affects the udder (tuberculosis of the udder occurs in 2-8% of all cases of tuberculosis), but also when tuberculosis attacks other parts of the cow.

Thus Mohler fed and also inoculated (injected under the skin) guinea pigs with milk from 56 tuberculous cows, which were free from udder tuberculosis, and found that the milk from 21% of these cows contained the virulent germs of tuberculosis.

Moreover, the milk becomes infected in other ways: 1. Tuberculosis of the bowels and womb of cows is common and the discharges from these parts soil the cow and thus the milk. 2. The germs of tuberculosis from consumptive persons (tuberculosis of the lungs) may enter milk as dried expectoration blowing about in dust (rare); or by means of the hands of consumptive milkers being soiled with their expectoration (rare). 3. Again, the discharges from tuberculous cows (expectoration, manure, vaginal

discharge) contaminate the surroundings, dust, utensils, water, fodder, etc., and so may find their way into milk, as they do into well animals. While it has generally been thought that the tuberculosis germs in milk are commonly derived from the udder of the diseased cow it now seems probable that the contamination of milk with manure of tuberculous cows is the most frequent source of the germ. Mohler has found the germs of tuberculosis in the manure of over 41 per cent. of cows of healthy appearance which showed no evidence of tuberculosis save by the tuberculin test. The tuberculosis germs present in the manure are, however, chiefly derived, not from disease of the bowel, but from the blood or discharge coughed up from the lungs and then swallowed by the animal.

The results of the examinations of some 1,287 samples of milk, chiefly by intraperitoneal injection into guinea pigs and rabbits, by some 18 or 20 experimenters in different European cities, show that 9% of milk contains active germs of tuberculosis. Anderson has shown that in Washington, D. C., approximately 11% of the dairies supply milk containing virulent tubercle bacilli.

The percentage of cows affected with tuberculosis varies widely in different herds and localities. Thus large herds are more apt to be tuberculous and 80 to 90% of the animals may have tuberculosis. In smaller herds and in those living chiefly outdoors the percentage may vary from zero to 50% affected with the disease. Of 24,685 cows tuberculin-tested in Massachusetts, 50% were found to be tuberculous. The latest statistics (1908) concerning the prevalence of tuberculosis among cattle in the United States are those of Melvin based on approximately 54 million cattle slaughtered and inspected for food, and 400,000 (mostly dairy cattle) tested with tuberculin.

He estimated that ten per cent. of milch cows and one per cent. of other cattle have tuberculosis. The use of tuberculin is the only positive test.

Just how common, and how important, therefore, is tubercu-

losis in the cow a source of the disease in man through drinking milk of tuberculous cows, it is impossible to say, but from recent studies it is probable that from 10 to 23 per cent. of tuberculosis in children owes its origin to milk, and in consequence it is essential that all cows should be tested with tuberculin, to exclude the possibility of tuberculosis, before the milk is used for any purpose.

* Koch states that of all the human deaths from tuberculosis, eleven twelfths are owing to consumption (tuberculosis of the lungs) and in *this form* of the disease the bovine type of germ has not been found. Therefore he does not attribute consumption to drinking milk.

Theobald Smith attributes half of the cases of tuberculosis of the abdomen and of the glands of the neck in children to the bovine type of bacilli and therefore to milk.

Nathan Raw ascribes tuberculosis of the lungs, larynx and intestines in man to the human type of bacillus; while human tuberculosis of the peritoneum, glands, joints, brain and skin, together with the acute miliary form, he believes are due to the bovine bacillus conveyed to man only in milk.

The germs of tuberculosis are not found only in milk, but in cream, cheese and butter.

Garget or inflammation of the udder (mastitis) is caused by external injuries and by infection with various germs which cause inflammation elsewhere in the body (as streptococci, staphylococci, colon bacilli and diplococci). These germs escape in the milk and so give rise to disease in persons consuming it. The milk is altered in character and is apt to be lessened in amount. It contains small whitish or yellowish lumps (pus and fibrin) and is often bloody, slimy or stringy. Such milk may have a bad odor and taste and may quickly curdle.

The commonest disorders produced in man by drinking milk

* Internat. Congress of Tuberculosis, 1908.

from cows with garget are digestive—as vomiting and diarrhea with prostration. Also severe sore throat (resembling follicular tonsillitis or diphtheria) and a condition simulating scarlet fever are seen. Garget is more common before or after calving and is discovered through the altered character of the milk and the appearance of flakes or small lumps in the milk, or stringy, bloody or thick milk, upon the cheese-cloth strainer covering the milk pail; by the occurrence of tenderness and lumpiness and swelling of the udder, and by the presence of the germs (noted above) in the milk (see p. 31). Milk from cows with garget—even when only one quarter of the udder is lumpy—is unfit for human consumption. By boiling such milk for 10 minutes it may be safely fed to animals. In the case of tuberculosis of the udder there is also hardening and enlargement of the udder—either affecting the whole udder or not uncommonly one of the rear quarters of the udder. Enlargement of the glands above and behind the udder (retromammary) is frequently the first sign. The milk secretion lessens, the color and consistency changes to a yellowish or reddish, thin fluid, with flakes of larger size than usual, and on standing there is a deposit of thick substance with watery fluid above. Finally, in advanced cases, the secretion is thick and yellowish from pus and contains curds, has an alkaline reaction, and is wanting in milk sugar. Tuberculous disease of the udder generally follows tuberculosis in other parts of the body (for method of finding the germs of tuberculosis in milk, see pp. 37, 276).

The most marked chemical changes in milk from cows with mastitis or udder tuberculosis consist in diminished content of milk sugar and increase in albumin and globulin from the contamination of milk with serum, blood and pus.

The milk from such cows may communicate the inflammation of the udder to other cows in the same barn by means of germs carried by the milker's hands. Therefore cows with caked or inflamed udders should be kept apart and milked by one not milking

the healthy cows. Nodules (or the miliary form) of actinomycosis may occur in the udder and the ray fungi from the disease may escape into the milk and produce the disease in man, when it is used as food by him. Botryomycosis may also attack the udder and render the milk unfit for food. The milk, butter, buttermilk and cheese from cows with foot-and-mouth disease has been the means of communicating this disease to man, giving rise in him to sore mouth, tender swellings under the jaw, an eruption of blisters or "cold sores" on the face, fever and disturbance of the digestion. Boiling and pasteurization (180° F.) destroys the germs of foot-and-mouth disease. Cow pox, milk fever, anthrax and pleuropneumonia (?) in cows have been conveyed by the germs of these diseases, in their milk, to human beings.

Some special diseases of cows have been studied in relation to infection of milk. Thus in that fatal form of dysentery of new-born calves (due to colon bacilli and proteus forms), and in infected navels of the new-born (septic umbilical phlebitis due to streptococci, staphylococci, colon bacilli, etc.), which is also accompanied with diarrhea, the milk is apt to be contaminated with the germs of these diseases in the atmosphere. Cows with an often fatal form of bloody diarrhea, accompanied by fever (hemorrhagic enteritis due to some of the colon group), may secrete milk containing the germs of the disorder and these may produce typhoid-like conditions in man consuming the milk. In various digestive disturbances of cows the milk is apt to be altered in taste (salty or bitter) and appearance (thin, yellowish, or it undergoes "sweet curdling").

Cows having a foul discharge from retained afterbirth and inflammation of the womb (septic metritis) should be removed from the barn, as the odor and germs in the vaginal discharge (colon bacilli and cocci of various kinds) will contaminate the milk of neighboring healthy cows. The milk from such diseased cows is not fit for use.

Cows having open sores, especially on the udder and teats, are

apt to contaminate their milk with the special germs to be found in suppurating wounds. Cows suffering from fevers of any description yield milk which may either contain special germs causing these disorders, or the poisons produced by these germs.

Cows with lockjaw (tetanus) or rabies may communicate these diseases to man by means of the specific germs in their milk. There appears to be some doubt as to whether these disorders have ever been actually transmitted to persons through the milk of cows sick of tetanus or rabies, but such milk should never be consumed by man or animals.

Milk sickness in man is due to a special bacillus (*B. lactimorbi*) escaping in the milk of cows suffering from Trembles, (p. 78).

The following drugs are known to escape in some amount in milk when given to cows. Other medicines may be excreted in milk also, as the subject has not been thoroughly studied. On general principles no powerful drug should be given to cows supplying market milk. Harmless drugs, as iron or simple bitters, would not damage the milk.

Opium	Mercury	Creolin
All volatile oils	Lead	Colchicum
Purgative salts	Zinc	Euphorbium
Rhubarb	Iron	Ergot
Senna	Bismuth	Salicylic acid
Castor oil	Neutral salts	Veratrine
Scammony	Ammonia	Strychnine
Jalap	Acids	Croton oil
Iodine	Sulphur	Aloes
Potassium iodide	Atropin	Turpentine
Antimony	Copper	
Arsenic	Carbolic acid	

It may be positively affirmed that the milk from a sick cow or one receiving powerful drugs, is not fit for human consumption. The milk of tuberculous cows may be safely fed to swine or calves after boiling for ten or more minutes.

The germs of typhoid fever, diphtheria and scarlet fever* (rarely of cholera, dysentery, malta fever, from goat's milk, and smallpox) occasionally find their way into milk, owing to the milk coming in contact with human patients suffering from these diseases, or with their surroundings, or from contamination of milk or milk utensils with water harboring the germs of typhoid fever.† Also, by wading in filth containing the bowel and urinary discharges of human beings, cows may contaminate their udders with germs of typhoid fever and thus convey them to milk.

Other agencies by which disease germs may be carried to milk and by which many cases of typhoid fever, diphtheria and scarlet fever have been communicated to man are as follows: by attendants in the sick room coming in contact with milk, by dish cloths, brushes and other articles coming in contact with the sick and milk utensils as well, by contact of milk with flies, dust, and by contact of milk with persons handling human excrement.

The chief source of milk infection is from patients at the farm, dairy or shop. Persons in the first stages of disease, or again those who carry the germs about with them after they recover, are especially likely to infect milk. Thus so-called "typhoid carriers" may disseminate germs for years from the bowels, and in the urine, etc. The germs of diphtheria occasionally remain in the throat for months after recovery, "diphtheria carriers." The method of sampling milk by tasting—so as to contaminate the milk by the mouth, or utensils touching the mouth—is of course a source of infection. Returned bottles from houses holding cases of contagious disease are a menace. Ice cream may be a source of typhoid germs, as freezing does not kill them. Typhoid germs also grow

* Physicians are required by law to report all cases of infectious disease to the local board of health. It should also be made mandatory that physicians state the name of the milk dealer supplying the patient with milk, in the case of every report of infectious disease, as is done in Mt. Vernon, N. Y. In this way epidemics originating in milk contamination with human infections could be readily traced.

† For "Typhoid Fever Case Card," see Appendix, p. 355.

in fresh butter, cheese and buttermilk. Inoculation of milk into guinea pigs, and growth of germs on appropriate culture material from samples of milk, may lead to the finding of disease germs in milk.

Of 253 milk-borne epidemics collected by Trask, and occurring since 1895, 179 were typhoid fever; 51 were scarlet fever; and 23 were diphtheria. Both the germs of typhoid and diphtheria may multiply in milk, especially if it is not properly cooled. Beginning with 78 typhoid fever germs in fresh milk there were 6,000 in 24 hours and 440 millions in seven days. Starting with 39 diphtheria germs in fresh milk, there were 1,170 in 24 hours and 19 millions at the end of a week (Eyre).

There are certain characteristics of epidemics originating from milk which will lead one to distinguish them from those derived from other sources. Thus the sudden onset. A number of cases suddenly appear in one day. Persons drink the infected milk at the same time and therefore become sick at about the same time.

Of next importance is the fact that all those taken sick have milk from the same source. This does not mean that they have taken milk from the same milkman, as the original infected milk may be mixed with other milk and may be sold by many milkmen. However, it is possible to trace the source of the infection by looking into the sources of supply of the milkmen distributing milk to the sick. To accomplish this it will be of great assistance if physicians be required to report the name of the milkman supplying milk to each contagious case reported by them. The decline of milk-borne outbreaks may be also more sudden than is usual in others. But this is not the case if the milk is constantly contaminated, nor if there are many new cases arising from contact with the sick. Several cases are apt to occur simultaneously in the same house in milk-borne epidemics. Then again those who drink most milk are prone to be the patients—as children and the well-to-do. The period of development of the disease is likely to be shorter and

the fatality less in milk-borne epidemics. It is usually not possible to find the germ of the disease in the infected milk.* This follows because it often happens the milk was contaminated but for a short time, perhaps but one day. Sometimes the milk is daily contaminated for a considerable period, but the germs may be greatly diluted in the milk or may be killed by the growth of lactic acid bacteria. In only one instance out of 179 milk-borne epidemics of typhoid fever was the typhoid germ found in the milk; and in but 2 out of 23 epidemics of milk-borne diphtheria, was the diphtheria germ discovered in the milk. If the source of the contaminated milk is found and its use stopped the epidemic will probably soon cease.

Disease germs grow best in pasteurized milk, since they are not killed by the germ-destroying substance in fresh, raw milk, nor by the acid produced by lactic acid bacteria. Readers who are particularly interested in milk-borne outbreaks of contagious disease are referred to Bull. No. 41, Hygienic Laboratory of the U. S. Public Health and Marine-Hospital Service.

The lesson which should be taken to heart is that no sick person or one coming in contact with persons sick with communicable diseases, should be allowed to have anything to do with the handling of milk, milk utensils or be permitted entrance to barn or dairy. Milk should be kept in a room separate from human habitation, and all the utensils should be kept and cared for in this milk room. Young children should be excluded from barn and dairy, as they are much more prone to contagious diseases than adults. Dogs and cats may be carriers of germs, dirt and parasites, and should also be kept out of these places. The water used in connection with the dairy should be examined for purity by a competent chemist. (See p. 75.)

* And it is not worth attempting unless from the original sample containing the infecting organism. Tubercle bacilli in milk are found most certainly by intraperitoneal injection of a guinea pig with the centrifuged sediment of 40 c. c. of milk in 2 c. c. of the same milk.

All forms of disease conveyed by germs in milk to human adults are as nothing in comparison with the damage wrought by germ-laden milk upon infants. Cholera infantum, in fact, is but another name for acute milk poisoning. Practically almost all the cases of summer diarrhœa in babies are caused by germs in milk. These are probably chiefly of the putrefactive type which enter milk from manure on the cow. Indeed, in some localities from 40 to 60 per cent. of the deaths in infants from all causes result from dirty milk. The wonderful reduction in the death rate of infants in some of our large cities—which is one of the remarkable signs of modern progress—has been brought about solely by the recognition of this fact.

This reduction is directly traceable to the use of pure milk or, where this is not obtainable, to pasteurizing milk, during which the growth of germs is killed or checked. Violent and often fatal poisoning, resembling cholera, is produced by a substance (tyrotoxin) formed by certain germs in milk kept in dirty, covered vessels during hot weather. The same poison has sometimes been found in cheese, cream and ice cream and has also caused fatal results.

Tyrotoxin is a ptomaine or chemical product due to the splitting up or putrefaction of milk-products by bacteria of the colon group. In ice cream the number of germs is often many times that common to milk or cream. This follows because the cream is often pasteurized, which kills the harmless lactic acid bacteria, and the cream is kept at a low temperature which allows other germs to grow which are harmful. 26 million germs were found on an average in the quarter teaspoonful in the examination of 263 samples of ice cream.* Streptococci are found (80%) twice as frequently as in milk. Storing ice cream does not lessen the number of germs but

* Ice cream is usually due to a toxin produced by the paratyphoid or typhoid-colon group of bacteria (*B. enteritidis* or *B. paratyphi*), which may occur in the feces of normal cows. Fecal contamination of milk is thus the immediate cause.

renders it much more dangerous by giving them time to form ptomaines in it. The danger of commercial ice cream lies in the dirtiness of the making and utensils, dirty cream to start with, and finally the keeping of it for many days.

When made from fresh, unpasteurized, clean cream, and eaten within a short time, ice cream is harmless. About 25 per cent. of market cream contains the germs of tuberculosis (see p. 96). These are not killed in ice cream. Therefore ice cream should be made of cream from tuberculin tested cows or from freshly pasteurized cream. Much of the commercial ice cream is dangerous to health.

Chiefly through the laudable and efficient work of Health Officer G. W. Goler, M.D., in supplying certified milk to the public of Rochester, N. Y., the infant mortality has been there reduced as follows: 1887-1896, before milk work was done, the average mortality in infants under 1 year in the month of July was 1,010; 1897-1906, after the milk work was begun, the average mortality was only 413 in July under the same circumstances.

TABLE I. (a)
GROUPS OF BACTERIA THAT GET INTO MILK.

Group	DESCRIPTION OF GROUP.	CLASS OF BACTERIA.
Group A	Lactic acid bacteria, ferment the milk sugar. Curdle or precipitate casein by acid. No further effect on milk.	1. Bacterium lactis acidi. Lactic acid produced. Favorable kind.
		2.† Coliform types { Bacterium lactis aerogenes } Bacillus coli aerogenes } Bacillus coli communis } Pseudomonas coli. } Lactic acid produced, CO ₂ , CII ₁ , H etc. Unfavorable kinds.
		3. Miscellaneous forms, produce lactic acid or several other kinds of acids. Some anaerobic. As a group not of much importance in milk.
Group B	Casein-digesting and peptonizing bacteria, liquefy gelatin, precipitate casein with alkaline reaction, with subsequent digestion of casein.*	4. Spore forming bacteria, resistant to heat, not killed by boiling.
		5. Motile bacteria, swim to every part of a liquid food.
		6. Non-motile, otherwise similar to 4 or 5.
		7. Acid liquefiers, often pathogenic, mostly spherical forms.‡
		8. Bacillus tuberculosis does not grow in milk.
		9. Diphtheria bacilli grow in milk.
		10. Scarlet fever germs do not grow in milk (?)
Group C	Disease bacteria and germs come largely from human sources, and individuals having the disease. Cause of serious milk epidemics.	11. Typhoid bacilli grow rapidly in milk.
		12. Cholera germs grow rapidly in milk (?)
		13. Diarrheal germs grow rapidly in milk (?)
		14. Chromogenic, color producing bacteria.
Group D	Indifferent forms of bacteria, non-liquefiers, produce very slight or no changes in milk, soon disappear and of no significance in milk.	15. Alkaline or neutral forms.
		16. All miscellaneous forms not included above.
		Alkaline bacteria, mostly rod shaped.

(a) Taken from Bull. 51, Storrs Exper. Sta.

* Cause poisoning by ice-cream and milk too long in cold storage and are the cause of gassy cheese.

† Class 2 in this group is responsible for diarrheal diseases of infants and is chiefly carried to milk by flies.

‡ Micrococcus lactis varians, probably the same as the Staph. pyogenes aureus, an organism known for a long time and associated with pus formation.

TABLE II. (b)

SOURCES OF BACTERIA THAT GET INTO MILK.*

Numbers in this table refer to varieties of bacteria in Table I.

COW.	Inside of Udder.	<p>Largely spherical forms, developing very slowly in milk, 14, 15, 16. Slightly acid forms, 3. In some cases pathogenic forms, 7, (<u>8, 9</u>),†</p>
	Surface of Cow.	<p>Feces, 1, 2, 4, 5, 6, <u>8</u>, 14, 15, 16. Hay dust 2, 3, 4, 5, 6, 7, <u>8</u>, 14, 15, 16. (No. 1 found in only one sample.) Grain feeds, 1, 2, 3, 4, 5, 6, 7, <u>8, 10</u>, 14, 15, 16. Soil dust, 3, 4, 5, 6, 14, 15, 16. Air distributed germs from any source. Indigenous on skin of cow, 1 (?), 7 (?).</p>
	Air.	<p>Hay dust, grain feed dust, soil dust, same as above. Medium of distribution for bacteria from all sources. Bedding furnishes one of the largest sources.</p>
	Flies. (July, Aug., Sept.)	<p>1, 2, 3, 4, 5, 6, 7, <u>8, 9, 11, 12, 13</u>, 14, 15, 16. Intestinal disease germs carried by flies.</p>
	Milker.	<p><u>4, 5, 6, 7, 8, 9, 10, 11, 12, 13</u>, 14, 15, 16. Hands, clothes, face, hair. The largest source of disease germs.</p>
	Milk Utensils.	<p>1, 2, 3, 4, 5, 6, 7, <u>8, 9, 10, 11, 12, 13</u>, 14, 15, 16. Water, dust, unsterile cloths or brushes, milk left in seams, crevices or in rusty places. Thoroughly sterilized utensils do not furnish any bacteria in milk.</p>

(b) Taken from Bull. 51, Storrs Exper. Sta.

* Bacteria injurious to milk and disease germs for man are indicated by heavy-faced type. Disease germs for man are indicated by heavy-faced type and underscored line.

† Bacteria (streptococci) in the milk from an inflamed cow's udder (mastitis or garget) may cause severe sore throat in a person drinking it, but not true diphtheria.—AUTHOR.

CHAPTER II

COMPOSITION OF MILK AND CREAM AND THEIR PRODUCTS

MILK is a white, opaque fluid, when seen in bulk, but appears transparent in thin layers. It has a peculiar, pleasant odor and taste which cannot be described. They can best be appreciated—by comparison—when they are absent. Thus, milk which has been heated in open vessels or passed through a separator loses some of its finest flavor. This flavor resides in a volatile substance which escapes in either process.

Milk has been called a vital or living fluid. This because of its semblance to other fluids in the living body and since it possesses some of the constituents and properties of these other fluids of the body. Like blood, milk contains cells—as fat and leucocytes—and opsonins, alexins, and various ferments. After 24 hours from its leaving the body milk becomes dead,—that is, the action of the ferments and germicidal properties are lost.

Chemically, milk is composed of all the essentials of a complete food. That is, it is a single substance which contains all the food-elements necessary to indefinitely support life. These food-elements are known technically as *Proteids, Fat, Sugar and Mineral Matters*. In reaction cow's milk is amphoteric, *i. e.*, it turns red litmus paper blue, and blue litmus red.

Proteids in milk have the same food value as flesh or eggs. Water is, of course, the largest constituent of milk, forming about 87 per cent. of it.

The solids make up the remainder of milk, amounting to about 13 per cent. and comprising the substances we have just enumerated, proteids, fat, sugar and mineral matters. The ash or mineral matters consists of salts of lime, potash, magnesium, sodium and iron in combination with chlorine, sulphuric and phosphoric acids. Omitting the mineral matters or salts, we may, in a general way, remember the proportion of proteids, fat and sugar as four per cent. of each, the percentage of proteids being slightly below and that of sugar slightly above these figures. The fat is the only one of these constituents which varies greatly and this indeed varies tremendously (from 1.5 to 13. per cent.) and owing to a great variety of circumstances which will be noted.

If the fat is all removed from milk—which can practically be done with the separator—we have left the skim milk, which is composed of the proteids, sugar and water. The sugar is of a kind peculiar to milk and therefore called milk sugar. It is found in no other substance and is not nearly so sweet as ordinary or cane sugar. The souring of milk is due to fermentation of milk sugar which takes place through the action of certain germs (lactic acid germs), which we have already mentioned and which are always present in the cleanest market milk. Since lactic acid bacilli enter the milk in dirt, dust, etc., outside of the cow, it is wholly possible to prevent them from getting into milk if milk is withdrawn from the udder through a tube into a clean, closed vessel and does not come in contact with the air. In this case natural souring will not occur. These germs lead to the breaking up (fermentation) of the sugar in milk into lactic acid (or milk acid). Milk sugar, sold in the shops, is made from sweet whey—a bye-product in cheese making. We have accounted for the sugar in the skim milk; we have left for consideration the proteids and mineral matters. The proteids are of three kinds: *Casein* (or *caseinogen*), *Albumin* and *Globulin*. Casein forms nearly four-fifths of the proteids (3 per cent. of milk) and is that part of milk which makes the curd

of skim milk, or the part of milk which forms the bulk of cheese. The word caseous means cheesy. The other kind of proteid or albumin remains mostly in the whey when milk is curdled. Casein exists in the form of a neutral, soluble lime compound, calcium-casein, while the albumin is in solution, together with the mineral matter, in the water of the milk.

In respect to curdling of milk, or coagulation of its casein, one must keep in mind the following as the three most common causes. (1) The most frequent—owing to souring—in which germs split milk sugar or lactose into lactic acid. The lactic acid breaks up the lime compound in which casein is soluble (forming calcium-lactate), and so casein appears in the form of insoluble curds. (2) Milk, or the casein in it, is curdled by rennet (or rennin), which is formed in the stomach of man and animals. (3) Germs curdle milk, also by means of a rennet-like ferment they produce. The curdling of milk by rennin is often called “sweet curdling.” Rennin splits casein into two bodies, paracasein and whey proteid. Here also the presence of lime salts in milk (calcium phosphate) is necessary for the formation of paracasein in milk by rennin and its precipitation as curd. In cheese making the development of lactic acid causes it to unite and form paracasein lactate. Then the removal of calcium salts from paracasein by lactic acid forming calcium lactate changes its physical consistency from a soft curd to a tough plastic curd which entangles most of the fat in the milk while pressure squeezes out the water and soluble proteids and sugar as whey. Boiling or heating milk beyond a certain point interferes with curd formation by rennin, since it throws down the lime salts. Sometimes germs cause curdling in milk by the production of both acid and rennin.

Globulin exists in but traces in ordinary milk but is present in considerable amount in colostrum. It coagulates at 167° F. Lactalbumin, or the albumin of milk, is not curdled or coagulated by the souring of milk, or by rennet, but is slightly by a temperature

FIG. 2.

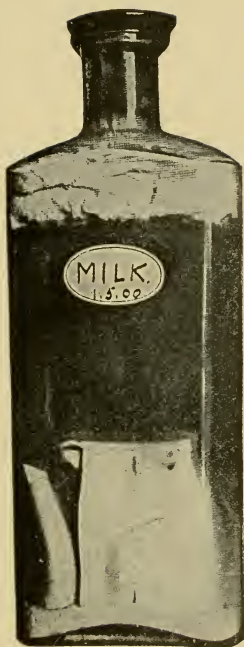

The Constituent Elements of Milk—Fat, Serum, and Casein.
(From Swithinbank & Newman).

over 162° F. About 1/11 part of the proteids of milk consists of lactalbumin.

If milk is kept a long while, the cream (mostly fat) rises to the top; the casein settles as another white layer to the bottom of the vessel, while in between these is seen a third clear layer (serum) consisting of water, in which remain dissolved the mineral matter, sugar, globulin and albumin (Fig. 2).

The fat in milk occurs as the most minute, microscopic globules which float through the milk and, on account of their buoyancy, rise more or less quickly to the surface and there form cream. These minute droplets of fat are apparently surrounded by a wonderfully thin pellicle or covering which has been thought to consist of a layer of casein adhering by capillary attraction. This surrounding membrane does not exist, according to recent research, milk being a natural emulsion. The fat globules vary greatly in size, some being six times the diameter of others. They average about 1-5,000 of an inch in diameter, and one drop of milk no larger than a pinhead may contain 1,500,000 fat globules. The difference in the size of the fat globules in different breeds of cows and in human milk is shown by Gilbert's table. A micron = 1/25,000 of an inch.

SIZE OF FAT GLOBULES IN DIFFERENT KINDS OF MILK.

	Human	Jersey	Guernsey	Ayrshire	Holstein
Average diameter in microns or μ ..	2.9	2.8	2.6	2.1	2.0
Average variation in microns μ ...	1.2	.9	.85	.76	.66

The larger globules of fat are most buoyant and rise to the surface; only the smallest remain in skim milk. The fat globules are larger in some breeds of animals, particularly the Jerseys, and the cream therefore rises more rapidly and completely. The size of fat globules in mixed milk varies from 2 to 30 microns. As the lactation period advances the globules diminish 2 or 3 times in size and increase 2 or 3 times in number. While there are breed dif-

ferences, in the size of the globules, there are great individual differences in the same breed. The fat globules are arranged in groups or clumps in milk instead of being uniformly scattered throughout the fluid. This is of considerable practical importance, for milk which has been separated or heated (pasteurized) does not cream so well because the clumps of fat globules are broken up and so do not rise so quickly or completely. For example, milk is passed through a separator revolving at the rate of 1,200 revolutions a minute, not fast enough to separate the milk from the cream (which is sometimes done to remove the dirt from milk or to "clarify" it), and the milk is bottled. The cream will rise from this milk slowly and incompletely, and the cream, when it has risen, will appear so thin that a twenty per cent. cream may not seem thicker nor richer than rich milk.

Pasteurizing milk will cause much the same result, if the milk is subjected to considerable agitation in the process.

If milk is cooled within a few moments of pasteurization to 40° F. and bottled immediately the cream will rise quickly into a smaller and denser mass than on unheated milk, but showing a good cream line.

The mineral matter in milk comprises a very small amount of variety of salts and altogether they do not form quite one per cent. of the whole milk.

The following table perhaps fairly represents the composition of what might be called average milk * from a large herd of average cows of various breeds:

	Per Cent.
Water	87.00
Fat	4.00
Proteids	3.30
Sugar	4.95
Mineral Matter	0.75

* The U. S. Pure Food Act of 1906 fixes the standard for milk as follows: Solids not fat, 8.5 per cent.; milk fat, 3.25 per cent.; milk solids, total, 11.75 per cent. Skimmed milk to contain 9.25 per cent. of total solids.

AVERAGE COMPOSITION OF WOMAN'S MILK.

	Per Cent.
Proteids	1.5
Fat	3.3
Milk sugar	6.8
Mineral Matter	0.2
Water	88.2

The chief differences between cow's and human milk are that the proteids exist in much larger proportion as albumin in human milk and that human milk is subject to greater daily variations in composition. Also there are ferments in human milk (amylolytic or starch digesting, and salol-splitting) which are not found in cow's milk.*

We will now consider in detail the various circumstances which modify the composition of milk. It is a curious fact that the character of the food of cows has little influence upon the composition of milk although it affects tremendously the yield of milk. The composition of the milk is dependent on the cow and breed, and is as much a characteristic as her color and as difficult to change. The following table illustrates the average composition of the milk of herds of different breeds of cows:

	† Durham or Short- horn	Devon	Ayrshire	Holstein- Friesian	Jersey	Brown Swiss	Common Native
Fat.....	4.04	4.09	3.89	2.88	5.22	4.00	3.69
Sugar.....	4.84	4.32	4.41	4.33	4.84	4.30	4.35
Proteids.....	4.17	4.04	4.01	3.99	3.58	4.00	4.09
Min'al M't'rs..	0.73	0.73	0.73	0.74	0.73	0.76	0.76

According to the statutes of the various states,‡ the required standard of composition of milk differs to a slight extent, but as much as three per cent. of fat is demanded in every state, except

* There is much more lecithin in the fat of human milk and the curd formed in the stomach is softer than that of cow's milk.

† Abstract of tables compiled by Mr. Gordon, of Walker-Gordon Laboratory. The figures for Holstein-Friesian in the case of fat are rather low; 3.2 per cent. fat would be nearer the minimum average.—K. W.

‡ Laws in force in June, 1900.

Rhode Island, and solids amounting to twelve per cent., in most states, and as high as thirteen per cent. in some.

The legal requirements for fat and total solids are often too high and unfair to owners of cows yielding milk below these standards or to those shipping milk which has not been thoroughly mixed. The Massachusetts standard requires that in the fall and winter months milk shall contain not less than 3.7 per cent. fat, nor less than 13 per cent. of total solids.

This works harm to owners of Holstein-Friesians, especially, as these cows often yield milk below the legal standard and yet it is milk best suited for infants.*

The composition of milk varies according to the period of milking, the milk growing richer in fat and the fat globules larger as milking advances, the last of the milking or "strippings" being very rich.

	Per Cent.
	Fat.
† Fore Milk	3.8
Middle Milk	6.74
Strippings	8.12

The reason for this is said to be that the fat globules are retarded by friction on the sides of the milk ducts in the udder and are forced out in abundance towards the last of milking. The percentage of the other solids remains practically unchanged at different periods of milking.

It is a curious fact that when the calf sucks the cow, the last of the milk appears to be much poorer in fat than the first part.

If cows are milked at frequent intervals the yield of milk is greater and the percentage of fat larger. The milk is formed in the cells of the udder and is conducted through numerous fine tubes of increasing size until it empties into a reservoir (holding about one-half pint on an average) connected with the upper end of the

* The standard for fat content must not, however, be removed or made too low so as to encourage production of low grade milk. Holstein milk may be much improved by breeding, see p. 68.

† Dr. Charles Harrington's analysis.

canal or opening in the centre of each teat. There are therefore four milk cisterns in the udder, one for each teat. It is probable that when the udder has become accustomed to hold in its ducts and cisterns a certain quantity of milk it will for a time secrete nearly the same amount during each interval between milkings. After a while, however—if the cow is milked more frequently than usual—the udder will not continue to secrete the same amount of milk and the exceptional quantity obtained by frequent milkings will cease. Milking three times daily is practiced in some parts of Europe, but milking more than twice in the twenty-four hours is rarely considered economical in the United States, and is not done except in the case of very heavy milkers or in cows newly calved.

Milk is formed continuously all the time and not chiefly at milking time, as has been thought.

Milking at the same hours twice daily, as at five A.M. and five P.M., gives the same amount of milk at each milking. Milking has no effect on milk formation. Frequent milking increases the milk-yield simply by more complete emptying of the udder. The longer the interval between milking the larger the quantity of milk and the poorer the quality of the milk; the shorter the interval, the smaller and richer the yield of milk. In the summer the nights are short and therefore the morning milking is apt to be richer. In winter the reverse is true and the night milking is likely to be the richer.

The following analyses of the milk of one herd at the Delaware Experiment Station show this:

	Night Milk Per Cent. Fat.	Morning Milk. Per Cent. Fat.
July 24th	3.76	4.67
February 5th	4.56	3.53

The season of the year influences the composition of milk. In the summer the percentage of fat and other solids is lowest. In the winter months the milk is richest in fat and solids not fat.

Thus in the months of November, December and January, the solids may average 13.36 per cent. and the fat, 4.16 per cent.; while in May, June and July the solids may average 12.68 per cent. and the fat 3.82 per cent.

The changes in the composition of one cow's milk are great and may be brought about through various influences, as, for instance, fright, excitement, rough handling, change of milker, exposure to bad weather, unfamiliar surroundings, sudden change in the character of food, and irregularity in time of milking. It follows without saying that all these unfavorable influences are, as far as possible, to be avoided.

In an analysis of hundreds of samples of milk from single cows, Farrington found that in the case of a Holstein there was as much difference between the highest and lowest percentage of fat as between 6.6 per cent. and 1.5 per cent., while in the case of the Jersey—in which sudden changes are most common—the highest was 12.3 per cent. of fat; the lowest, 2.9 of fat. The variations in the percentage of the other solids—proteids, milk sugar and salts—are very slight, especially of milk sugar.

The mixed milk of a large herd is pretty constant in composition except as influenced by the season and by the times the cows calve. For the composition of milk varies at different times in the milking period. The milking period of the cow lasts about 323 days on the average after calving, she going dry about eight weeks before she calves again. The interval between two calving days averages about 398 days.

In cows which are well tended and fed the percentage of fat increases as the milking period progresses, so that the milk is richer at the close than at the beginning of the period of milking.

The period of heat in a cow is often accompanied by a diminished yield of milk which is poor in fat (so that the fat may be reduced to one per cent.), and the milk curdles on boiling. The fat after this period is, however, proportionately increased over that

usually present. When cows are constantly in heat (nymphomania, "bullers") the milk yield is diminished and the composition may be altered. Abortion, while lowering the amount of milk, does not influence the composition—unless the cow is otherwise sick.

The milk-yielding capacity of cows generally increases up to the eighth year of age, and then decreases. With the decrease of yield there appears to be often a decrease in fat and total solids in the milk. It was thought at one time that the spaying of cows would prove of advantage in sustaining the yield and improving the richness of their milk, but it has not been found so in practice, except in those animals which are constantly in heat owing to disease.

The dehorning of cattle is said to improve the yield of milk, but there can be no conceivable reason for this other than in the freedom from fighting and wounds which this practice accomplishes.

The composition of milk is of great importance in that the value of milk depends upon the amount of fat it contains, other things being equal.

It has now become the custom for creameries in most parts of the country to pay a sum for milk proportionate to the amount of butter-fat it contains as estimated by the use of the Babcock machine at certain stated intervals. First-class, pure or "certified" milks now sold for an advanced price in cities should contain a high average of fat, unless sold exclusively for infants' use. Such milk often averages five per cent. Then again it is for the farmer's advantage, if he is to produce a high quality of milk, that he know the composition of the milk of all his individual cows so that the poorer ones may be weeded out. This may be accomplished by the use of a Babcock machine on the farm (see p. 193).

Colostrum (common name beastings, etc).—Colostrum is the milk secreted immediately after calving and differs very markedly in composition from ordinary milk. Colostrum is of a slightly yellowish or brownish color and has a peculiar smell, a slimy con-

sistency and salty taste. The proteids are at first large in amount and represent albumins and globulins (9 to 10 per cent.) rather than casein. For this reason the milk becomes curdled on boiling and this is a test for colostrum; if it curds on boiling it is unfit for use.

The sugar in colostrum is not milk sugar, but represents several other varieties. The percentage of fat is variable, while that of mineral matter is high. Colostrum usually separates into two layers on standing. Under the microscope there are to be seen in it very large globules of fat, called "colostrum corpuscles," and these are characteristic of this form of milk. The colostrum varies in composition from one milking to another after calving, becoming more and more like ordinary milk.

The following analysis will give an idea of its composition:

	Per Cent.
Water	78.7
Fat	4.0
Proteids	14.8
Sugar	1.5
Mineral Matters	1.0
	<hr/>
	100.0

While the proteids in colostrum are so soluble that they can be absorbed by the calf without any tax on its digestion, and appear to start up digestion in this animal, yet colostrum is not wholesome for man for from five to twenty days after calving. Legal requirements vary somewhat, but usually demand that cows' milk shall not be sold for fifteen days before, nor from five to twelve days after the calving of the cow supplying the milk.

The boiling test, referred to above, will show when the milk is fit for human consumption. The milk is not fit for churning until five days after calving, nor from ten to twelve days for making cream cheese.

Colostrum milk and the milk obtained from the cow within fifteen days before calving have produced disease in man. Colos-

trum has caused high fever, inflamed throat and mouth, which were covered with small sores or ulcers; while milk from cows, withdrawn a few days before calving, is sometimes the source of colic and diarrhea in the human. When cows give less than three quarts daily their milk is unfit for human consumption. The milk from a cow immediately after calving frequently contains blood, coming from that which soils the udder and tail after flowing out of the vagina.

CHAPTER III

MILK PRODUCTS

IT is a curious fact that the quantity of cream obtained from setting rich or poor milk is about the same for rich as for poor milk, but the cream from the poor milk is much thinner and contains less fat. As seen in a glass quart milk-jar, the layer of cream forms almost a quarter of the bulk of the contents of the bottle, at first, but after twenty-four hours or longer the layer of cream becomes less, owing to the crowding together of fat globules. When cream rises in tall vessels it contains a great deal more fat in its upper than in its lower layers.

In fact, of the cream which rises in a bottle of milk, the upper ounce contains as much sometimes as 25 per cent. of fat, while the fat in the cream regularly diminishes until at the lowest part of the layer of cream, which can be seen as a sharp line above the milk, the percentage of fat is not quite 10 per cent. The cream line in bottled, pasteurized milk is apt to be poorly defined since the natural clumps of fat globules in the milk are broken up by pasteurization and the cream rises incompletely. This is a serious disadvantage if it is desired to remove the cream for infant feeding or other purposes. As we have already said, the higher the creaming temperature the richer will be the cream, and for this reason the quantity of it will be much less than from the same amount of milk which is set at a low temperature. For the lower the cream temperature, especially at the end of the creaming period, the greater will be the amount of cream and the thinner will it be owing to the greater quantity of water in it. Milk which has been watered throws up

its cream much more rapidly than other milk. This accounts for the custom, with many farmers, of pouring a considerable amount of cold water into their milk cans when they wish to secure cream quickly for their own use.

Separator Cream

By the use of a separator, which consists of a rapidly whirling steel bowl (5,000 revolutions, more or less, per minute), the heavier portions of the milk—the skim milk and dirt—are thrown against the inside of the rotating bowl by centrifugal force, while the lighter portion—the cream—remains near the centre. The dirt sticks to the side of the bowl, where it forms a tough, sticky layer known as separator slime. This separator slime is not composed by any means of filth entirely, because a good part of it is made up of the proteid constituents of the milk (curd); one authority says that nine-tenths of the dried slime is formed of this natural product of the milk. That there is a great amount of filth in ordinary market milk has been abundantly shown. It has been estimated that the citizens of New York eat daily ten tons of barn filth and refuse in their milk. This amount is probably exaggerated, since Berlin is said to furnish its inhabitants but 300 pounds of cow dung in its daily milk-supply, and, allowing a wide margin for our native progressiveness, we could hardly be credited with beating the Germans so tremendously in this international filth contest. In the separator slime are to be found, in addition to the cheesy matter from milk, manure, fodder, hairs, particles of skin, insects, down from birds, threads from clothing, bits of bedding, cobwebs, bristles, soil, etc., and large quantities of germs. The slime forms from .04 to .3 of 1 per cent. of the weight of the new milk, depending upon its original state of cleanliness.* The use of the separator is superior to all other methods of obtaining cream on account of its

* Separator slime should be burned to destroy tubercle bacilli in it. It should never be used to feed swine.

power to more rapidly and thoroughly extract fat from milk. Thus it shortens the period for growth of germs permitted by the older methods of creaming, and—to some extent—removes germs already present in the milk. The cream, however, will be found to contain as many or more germs as the milk did before separation, although the skim milk leaving the separator may show one-third to one-half less germs in pretty clean milk, but in filthy milk the number of germs after separation is practically unaltered. Recent experiments show that of the germs present in whole milk before separation, 47 per cent. appear in slime, 29 per cent. in milk and 24 per cent. in cream after separation. (Eckles & Barnes, Iowa Sta. Bull., 1902.) Cream, after separation, must therefore be rapidly cooled down from the high temperature of separation (86° F.) to 40° F. in order to prevent the growth of germs which have not been removed to any great degree by the process.

The use of the separator to free milk of germs is not a success, although this method has been practiced in large cities to cleanse or “clarify” milk.

None of the disease germs occasionally present in milk is certainly removed by separation. When used to cleanse milk the separator is run at a comparatively low speed so as not to separate the cream from the milk, but sufficient to remove much of the filth and therefore the so-called animal odor. Although there may be an improvement in the flavor and odor of the milk, it will not keep any longer, showing that germs are not removed. Filtering milk by various devices has about the same value.

The filth and insoluble dirt are removed more or less completely, and the taste and odor improved thereby, but dirt, as manure, which is dissolved in the milk and the essential contamination—the germs—are not removed. For, as Professor Conn has pointed out, the germs are so minute and so much smaller than the fat globules that it would be necessary to employ a filter which would remove all the fat in the milk in order to catch the germs in the filter.

Dr. Seibert states that by filtering milk through one-half inch of compressed cotton seven-eighths of the bacteria are removed. This is a very slow process and some fat is removed by it.

Complete separation of milk into cream and skim milk is sometimes done for cleansing purposes, the skim milk and cream being reunited. Many physicians believe that milk thus treated is often the cause of indigestion in infants.

Neither these nor any other methods will make dirty milk clean.

Contamination of milk begins at the farm, and only at the farm can it be eradicated. Absolute cleanliness with respect to milking and everything which comes in contact with the milk, together with immediate cooling to below 50° F., will alone insure success. The importance of germs in relation to milk is as great as to the operating surgeon, and the amazing progress in both surgery and dairying is due chiefly to the appreciation of this fact.

Exclusive of fat, the percentage of the other constituents of milk—proteids, sugar and mineral matters—is about the same in cream as in milk, unless the cream be of unusual richness. For the same reason, the composition of skim milk is about the same as whole milk, the fat excepted. The fat is practically absent from separator skim milk and is present in skim milk, from which the cream has been removed by hand, to the extent of one-half to one, or even one and one-half per cent. The following tables illustrate these statements:

	Composition of milk Per Cent.	Composition of 20% Cream Per Cent.	Composition of 25% Cream Per Cent.	Composition of 67% Cream Per Cent.
Fat	4.00	20.00	25.00	67.00
Sugar	4.50	4.8	4.8	2.2
Proteids	3.5	3.05	3.2	1.2
Mineral matters .	0.7	0.6	0.7	0.1

	Composition of Hand-skimmed Milk Per Cent.	Composition of Separator Skim Milk Per Cent.	Composition of Separator Skim Milk Per Cent.
Fat	0.75	0.12 (hand)	to 0.1 (power)

The cream from set-milk contains 90 to 99 per cent. of the germs which were present in the whole milk, because in rising the fat globules entangle the germs and carry them along to the surface. These germs are chiefly made up of the varieties which cause the souring of milk or cream (lactic acid bacilli), and these increase for forty-eight hours at favorable temperatures—60° to 70° F.—in cream, and then gradually die out, owing to the unfavorable influence of the acid formed in souring, so that in a week few remain. During the first few hours there are to be found a great variety of germs in milk and cream, but the lactic acid bacilli crowd these out, because they grow so much more readily than do the other kinds of germs, and at the end of forty-eight hours there may be as many as 500,000,000 lactic acid germs to the quarter teaspoonful. Butter is commonly made from cream which has “ripened.” By ripening is meant the changes which occur in cream owing to the growth of germs in it during the process of souring.

The ripening of cream may be compared to the change which takes place in grape juice when it turns to wine. Both changes—in the grape juice and cream—are brought about by fermentation, and fermentation is simply a term for describing the changes—chemical and physical—which occur in a substance owing to the action of germs * and their products upon it.

In the ripening or fermentation of cream the germs alter the character of the cream and supply bodies which give to the butter its peculiar flavor and improve its keeping qualities. Butter made from fresh cream has less flavor and does not keep well. The sour milk germs give butter part of its flavor, but the miscellaneous germs which are crowded out by the former also are responsible for much of the flavor. In this country the popular palate requires a much stronger flavored butter than the European taste, which regards our butter as rank in flavor. Therefore abroad it is often customary to pasteurize fresh cream to kill the miscellaneous germs

* Or, rarely, to the action of ferments or enzymes.

and add the sour milk germs in the form of a "starter," thus getting a butter made from ripened cream, but avoiding the stronger flavor caused by the miscellaneous germs. The flavor and aroma of butter, then, depend upon the varieties of germs in cream. Butter is thought to possess the finest flavor in May and June because at this season the greatest variety of germs flourish in the milk.

The chief reason why butter is so much better from certain dairies than others is because the better dairies are the homes of special kinds of germs, which give butter a good flavor and aroma, while in the others—owing to want of cleanliness of the cows, barns, milk rooms, employees or utensils—special germs of filth which are unfavorable to good dairy products come to occupy the premises.

The action of the germs is, then, the essential factor in the production of good butter, as in all other departments of dairying. As we have pointed out, the lactic acid germs, while in the minority in the milk just drawn from the cow, soon gain ascendancy by multiplying in milk or cream, and it is to this type of germ that the ripening of butter and of cheese is chiefly due.

We have also shown that to the miscellaneous germs in milk and cream butter owes some of its flavor. But as some of these are deleterious to flavor and aroma, and are not to be depended upon, the endeavor has been made to employ only the lactic acid bacilli to ripen cream. These are present in pure culture; that is, they form the only type of germ in the commercial starters, which may be bought in market in various shapes, as bottles of milk, pastes, powders and pellets, all merely vehicles for the growth and preservation of lactic acid germs. This starter is added to fresh cream to ripen it. If the cream is already sour it is useless to add a starter. It is best to first heat cream to 155° F., to destroy the miscellaneous germs, before adding the starter containing the lactic acid germs, but in this country, where the added flavor caused by the miscellaneous germs is desired, the starter is more commonly added to fresh cream. The starters which were first used consisted

simply of a quantity of sour milk or cream containing a great number of germs, suitable for ripening cream, which was added to fresh cream to quickly sour and ripen it, especially in cold weather. These are called natural starters, and are still used extensively. To prepare such a starter the milk is withdrawn from the cow in the most cleanly manner; the milk is then separated and the skim milk is collected in an absolutely clean vessel and set aside at a temperature of 60° to 70° F. to sour. This sour milk may contain all sorts of germs, but if it is clean there are apt to be few miscellaneous germs and these are likely to be crowded out by the growth of the lactic acid germs, so that the result may be almost as pure a culture or collection of lactic acid bacilli as is found in the commercial starters. We quote the following from Farrington:

The foundation material for both kinds of starters is usually skim milk. This is first freed from most of its bacteria by heating it to 180 deg. F. or above, for at least one-half hour. It is a good plan to keep this hot milk well stirred and covered while it is being heated. After this period of heating, the skim milk is cooled. The cooling is usually done by setting the can of hot skim milk into cold water. The quicker it is cooled the better. When the temperature of the skim milk reaches 80 deg. F., it is then in condition to receive either the pure culture which has been brought from the dealer, or the sour milk which has been selected and allowed to sour naturally.

The so-called commercial starters are made by adding to about a gallon of this skim milk a small quantity (about an ounce) of the pure culture which has been brought from a dealer in this material. After the pure culture has been added to the skim milk the mixture is kept at a temperature of about 80 deg. F. until the skim milk has become soured by the pure culture bacteria. This preparation is sometimes called "startoline," and it may amount to about four quarts of sour milk. This is added to a larger quantity of pasteurized skim milk, which has been prepared by heating and cooling as previously described, and the mixture is allowed to stand at a temperature near 80 deg. until it becomes sour and has an acidity of about six-tenths of one per cent.* If the cream in which the starter is to be used is now ready, the starter may be added to it in about the proportion of ten pounds of starter to one hundred pounds of cream. A small quantity of this starter is saved each day and added to a new lot of pasteurized skim milk. In this way the starter is carried on from day to day and a new lot for use in ripening cream is prepared every day.

The natural starter is made in exactly the same way as the commercial starter, except that in place of the ounce of pure culture which is bought

* See page 190.

from a dealer, a small quantity of selected sour milk is added to the pasteurized skim milk. The starter is then built up from this mixture as before described.

This in general is an outline of the methods used for making cream-ripening starters. The successful handling of starters depends entirely on the carefulness with which the skim milk is pasteurized and the skill used in protecting the starter from outside contamination by dust, dirty cans, etc. In some cases the butter maker often goes so far as to wash his hands before handling his starter. These refining precautions used to protect the pure culture and the starter from contamination are very important.

If the starter does not give satisfactory results, it is best to throw it away and begin a new one; but, when once obtained, a good starter should be propagated from day to day as long as possible, and the length of time which it may be kept pure depends on the care with which it is made from day to day.

It is always better to seed a new lot of pasteurized skim milk with a portion of fresh starter taken out just before it is poured into the cream, than to attempt to propagate a new starter every day by means of buttermilk obtained from a churning of cream in which the starter was used. A buttermilk starter may often give good results; but, as a rule, it cannot be depended on, because some unpleasant flavors may develop in the cream during its ripening. These, of course, are carried into the buttermilk, and when this is used for making the next starter, the unpleasant flavors may be continued in the butter from day to day.

One of the important elements in starter making is the ability to detect a satisfactory starter when it is made. A person with a keen sense of smell and taste is able by inspection to select a good starter and know that it will produce good results, while other persons, without this ability, are unable to accurately judge between two different starters and they may keep on using a poor one day after day without noticing it. This faculty of judging starters may be cultivated by practice, and the butter maker who is most successful in training himself to detect a good starter, and a poor one as well, will be the most successful in making butter of a fancy grade.

The commercial starters are more expensive, but uniform, certain and convenient; while the natural starter costs little or nothing and is less uniform but generally successful. Both are in common use.

Butter made from ripened cream, besides having more flavor, aroma and better keeping qualities, is more readily churned and can be obtained in somewhat larger quantities than from fresh cream. Butter made from fresh cream is preferred by many persons, and, perhaps it may be said, by those with the most refined taste. However, the market for such butter is limited and it must be sold

immediately it is made. Fresh separated cream is much more readily churned than gravity cream.

Cheese is made from the curd (casein or cheesy portion) of milk obtained by souring milk or by curdling it with rennet, chiefly by the latter method. The whey is removed in different ways. In soft cheese, as Brie or Camembert, the whey is merely permitted to drain naturally from the curd. The whey being not all removed, soft cheeses keep poorly.

In the case of hard cheeses, the curd is cut up, and sometimes heated to 110° F. to toughen it, and pressed for days. Both soft and hard cheeses must ripen, which process takes days or months. The lactic acid germs are those chiefly instrumental in ripening hard cheeses, while molds and miscellaneous germs ripen the soft cheeses. In ripening, the various flavors characteristic of the special cheese are developed through the action of chemical products formed by the growth of these vegetable parasites or germs. In addition, the cheese becomes softened, and therefore easier of digestion through the action of a ferment natural to milk, resembling rennet, the latter being a secretion of the animal stomach.

How important is the influence of special varieties of germs in the successful making of cheese may be appreciated from the fact that it is a practice to smear shelves and walls of new factories with fresh cheese (as Brie and Limburger) to convey to them the special germs necessary to produce the flavor and characteristics of the cheeses which it is desired to make. A starter is often added to milk from which American cheese is to be made. As in the case of cream for butter, the addition of the lactic acid germs tends to crowd out miscellaneous and undesirable germs and give a more certainly uniform product. The commercial starters are most reliable for the ripening of cheese, as for butter. As a general practice, milk cannot be pasteurized to kill the undesirable germs before adding the starter, when cheese is to be made, because heating the milk destroys the ferment in it which assists in ripening cheese, and heated

milk does not curd so well with rennet. Certain of the sour milk, and of the soft and hard cheeses are, however, made successfully from pasteurized milk or cream to which is added a starter.

If cheeses made from unpasteurized milk, to which starters containing lactic acid germs have been added, are ripened in low-temperature cellars, the miscellaneous germs are not likely to develop.

The chemical composition of buttermilk and whey, bye-products in the manufacture of butter and cheese, is given below.

Buttermilk is usually sour from lactic acid, while the proteids are more digestible than in ordinary milk because existing in a flaky form. Quite recently the advantages of concentrated and preserved buttermilk have been advocated. Its use will probably become much extended in time. Also an innovation is buttermilk made from clean skim milk. This should be set at 70°-80° F. to clabber when it is churned until the casein is in a finely divided state and immediately cooled to below 50° F. and sold within 24 hours. A pasteurized skim milk may be used.* There is a great field for absolutely clean buttermilk thus made for consumption in cities.

Whey possesses but slight food value, containing only the ash, sugar and albumin of milk. It is sometimes the only food, when combined with a little cream, which infants with delicate digestion can tolerate.

We also append a table showing the composition of butter.

	Buttermilk Per Cent.	Whey Per Cent.	Butter Per Cent.
Proteids	4.06	0.81	1.00
Fat	0.93	0.36	84.00
Sugar and Ash	4.40	5.71	3.00

Good cheese contains about 33 per cent. each of proteids and fat, and possesses two to three times the food value of meat, providing it is well digested, as it is more apt to be if cooked with macaroni or vegetables.

* To which is added a starter.

Skim Milk

Skim milk forms a valuable food for man or beast, especially for calves and pigs. The milk should be fed young animals sweet, and warmed to the temperature of the body, when it possesses about one-half the value of whole milk for food. The use of the hand separator at the farm will often be found lucrative, for the reason that the skim milk may then be obtained warm and fresh for calves or pigs and the cream bring as large a price as the whole milk, while retaining the most valuable element—the nitrogen in the proteids of the milk—on the farm. This because the nitrogen is returned to the soil in manure. For man, skim milk, through its proteids, is said to be three times as cheap as meat, though a much more bulky food. If the skim milk is returned from the creamery for feeding, it is best that it be first pasteurized to kill any germs of tuberculosis which may be contained in it and to prevent souring. Indeed, when skim milk is to be fed either calves or pigs, or other animals, it is best to previously boil the milk for 10 minutes unless the cows yielding it are known to be positively free from tuberculosis. Calves should be permitted to suck the first day of their existence, and then may be given whole and skimmed milk for ten days, gradually reducing the whole milk. After that time they may be given only skim milk, five to six quarts daily in three feedings for the first two weeks. At the end of this time five pints of skim milk may be fed twice daily with a tablespoonful of flaxseed or Indian meal to supply the deficiency of fat in the food. A liking for corn meal may be encouraged by placing a little on the tongue after feeding milk. Skim milk is fed pigs in the proportion of three pounds to one of corn meal; to fowls, also, with grain. The utensils and troughs in which the skim milk is fed to young animals should be kept scrupulously clean, and the milk should not be fed sour. Rich milk is less desirable for feeding calves or pigs than milk comparatively poor in fat or skim milk. Rich milk leads

to indigestion and diarrhea and not infrequently causes the death of Jersey calves living on their mother's milk.

Bye-Products

In speaking of milk products the bye-products of milk are used to an extent in the arts but little appreciated. This has recently been brought out in an address at Chicago by Dr. Nowak, the inventor of a process for using skim milk in the tanning of leather. The curd or casein of skim milk is the essential part of the milk employed for the following manufactures:

For sizing straw and felt hats; for making and glazing paper; for glazing and finishing leather; finishing and sizing silk, cotton, woolen and linen goods; for making wall paper, roofing paper and linoleum. Also, casein is an important ingredient of cements, glues, putty, woodfillers, paints (especially dry paints), imitation ivory for balls, and buttons, etc.

Some of the most lasting of the old Roman structures were made from a mixture of milk, lime and sand, and the most celebrated old mural decorations of Europe from casein mixed with color.

CHAPTER IV

FEEDING FOR MILK

IN feeding cows for milk the most essential fact to grasp is that the composition of milk cannot be altered to any extent by feeding. The solids may be increased slightly by a food very rich in protein, or, on the other hand, the solids may be lessened, if the diet is very watery, but the percentage of fat, sugar and proteids in the milk is not affected to any degree by different kinds of foodstuffs. One often reads of the marked influence of a change of food in increasing, or otherwise, the percentage of fat in the milk. But, while a sudden change in the ration may produce a corresponding alteration in the percentage of fat in the milk, it will be found only a temporary matter. The single exception to the rule that the composition of milk is not changed by feeding is when the animals are not in a normal condition. If an animal has not enough food to be maintained in a normal condition, there may be a disturbance of the functions of the udder, as of any other function in the body, and therefore alteration in the composition of the milk.

The theory adopted by many physiologists teaches that milk is formed by the constant breaking down of the substance of the cells of the udder into the proteids, fat, and perhaps to some extent the sugar, of milk. This process is followed by a rapid rebuilding of the udder cells. But, while it was formerly thought that the entire udder cells were being continually destroyed in the

* Consult also page 351 for recent advances in the science of feeding animals.

making of milk, it now appears that only the free end of the udder cell is broken down. The contents (protoplasm) of the base of each cell, together with the cell nucleus, is not destroyed but—after the remaining portion of the cell has been changed into milk constituents—the cell is rebuilt.* The constituents of the food of cows are not transformed directly into milk, but are altered and absorbed into the blood and serve only to build the cells of the udder, as they do any other part of the body.

Moreover, it is probable that the content of the udder cells (protoplasm) is not directly changed into fat, proteids, and milk sugar, but that the cells manufacture these substances out of the materials brought to them by the blood.† There are perhaps some 136 million fat globules formed per second in the milch cow's udder, which, it is estimated, would require complete renewal of the entire secreting tissue of the udder several times daily—if the udder cells were directly transformed into fat. Fat in the milk is not then due to a breaking down or fatty degeneration of the udder cells, but is a deposit of fat in the cells manufactured from the blood and lymph.

No one of the separate constituents of milk is directly derived from similar constituents of food. Fat in milk is not derived directly from fat in food, but indirectly is formed from fat, carbohydrates and proteids in food. Indirectly, because these substances are greatly altered before and after they reach the udder in the blood.

Therefore an excess of fat in the food, for instance, will not increase fat in the milk. The kind of food does not influence the composition of milk so long as the food is sufficient in amount and properly proportioned or "balanced" in its constituents to fully nourish and sustain the animal.

The *quality* or composition of the milk from any cow depends upon the natural characteristics of the cells of the udder; the *quantity* of milk depends on the capacity for rapid cell-building and, to a degree, upon the size of the udder. But, although the

* This destruction is probably confined to but a few of the udder cells, however. It is thought that globulin is thus a product of broken down cells.

† Fat, casein and milk sugar are the results of glandular activity of the udder cells.

composition of milk is unaltered by food, the quantity of milk secreted is directly dependent upon the amount and kind of food. The cells of the udder being made of a substance similar chemically to the proteids of the milk, there must be an abundance of protein in the food to constantly rebuild these cells as they liquefy into milk. Indeed, the proportion of protein in the food has to be higher in feeding for milk than for any other purpose. This proportion has been determined by experience and experiments (see Wolff's table below).

While it is possible to secure the proper proportion of protein by the use of the greatest variety of fodders, the special foodstuffs which may be employed in any given case should be determined chiefly by the local cost of special fodders and the price of milk.

The richer a food in protein the more costly is it, and, if the price of milk is low, it may not pay to increase the amount of proteids in the food sufficiently to attain to the maximum milk-yield. A food rich in protein tends to sustain the period of lactation and keep up the flow of milk—which is ordinarily greatest soon after calving—for a considerable period. In case of large milkers which receive an insufficient supply of protein, the proteids of the tissues of the body are called upon to make up for the loss of protein in the formation of milk from the udder cells, and the animal rapidly loses flesh.

Notwithstanding the fact that the composition of milk cannot be materially altered by feeding under ordinary circumstances, yet by good feeding and breeding (taking advantage of increased fat yield in milk through careful selection), it has been found possible in several generations to produce an animal giving milk one per cent. richer than that common to its breed. This has been accomplished by some in the case of the Holsteins.

Wolff's original feeding standard for milk cows, per day and 1,000 pounds live weight, is as follows:

	Pounds
Digestible protein	2.5
“ fat	0.4
“ carbohydrates	12.5
Total dry matter	24.
Nutritive ratio	1 to 5.4

The nutritive ratio means the proportion of nitrogenous to non-nitrogenous constituents of the food. The protein represents the nitrogenous, and the fat and carbohydrates together represent the non-nitrogenous nutrients, as the food constituents are called. But to put fat on the same basis as carbohydrates, in calculating the nutritive ratio, the percentage of digestible fat is multiplied by 2.25 and the result is added to the total of digestible carbohydrates. The reason for this is because fat is thought to have two and one-quarter times the food value of carbohydrates, since a given weight of fat produces two and one-quarter times as much heat in burning as carbohydrates. This method of reasoning is realized, however, to be very imperfect.* In books† on cattle feeding tables showing the composition of foodstuffs may be found. The carbohydrates are found under the headings Crude Fibre and Nitrogen-Free Extract. There are other tables showing the percentage of digestibility of the fat, protein, crude fibre and nitrogen-free extract in the various fodders.

By multiplying the amount of any of these constituents in any given fodder by the percentage of the constituent digestible, we get the quantity of the digestible constituent in the fodder. Thus, if we look at a table showing the composition of hay: Average hay we find contains in the 100 lbs. as follows: 9 lbs. protein, 2 lbs. fat, 43

* The exact nutritive value of fat as compared with carbohydrates is shown by recent experiments to be as follows:

1 gram of carbohydrates = 4180 calories.
 1 gram of fat = 9400 calories.

A calorie (small) is that amount of heat required to raise 1 gram of water 1 degree centigrade. Therefore the heat value of fat is about 2.25 times that of carbohydrates, rather than 2.5 times, as has hitherto been accepted.

† Armsby's "Manual of Cattle Feeding."

lbs. nitrogen-free extract, and 26 lbs. crude fibre. To find the digestibility of these nutrients we look in another table and there discover that 46 per cent. of the fat in hay is digestible, 57 per cent. of the protein, and that the total amount of nitrogen-free extract in a coarse fodder represents the total quantity of digestible carbohydrates it contains. So in our 100 lbs. of hay we calculate that there are 5.13 lbs. of digestible protein (multiply $9 \times .57$); and 0.92 lbs. of fat (multiply $2 \times .46$) and 43 lbs. of carbohydrates digestible.

When we cannot figure the amount of nitrogen-free extract as equal to the total digestible carbohydrates, as we do for convenience in a coarse fodder, we find the amounts of digestible crude fibre and nitrogen-free extract in the tables and add them together to represent the total digestible carbohydrate in the foodstuff. Fat is often spoken of as ether extract by some writers. It is not necessary, of course, to try to secure a ration which shall be the exact chemical counterpart of Wolff's table above, but only to approach it as nearly as may be, especially in the matter of protein. The general idea should be to take the foodstuffs at hand and look up the amounts of digestible nutrients* they contain and combine them in the proper proportions as indicated by Wolff's table. Protein† is an expensive food constituent or nutrient, and it should be fed in the cheapest form of fodder available in the locality. The best manner of feeding is to weigh out the food necessary for the whole number of cows at one feeding and distribute the amount to each cow in proportion to her weight, secretion of milk, etc. Professor Haecker's work on cattle feeding teaches that the daily quantity of nutrients should be proportioned to the amount and richness of daily milk-yield as displayed in the following table.‡

* Armsby's "Manual of Cattle Feeding."

† In cattle foods protein costs, by weight, twice as much as carbohydrates and about one-half as much as fat, but there is ordinarily enough fat in a ration.

‡ The following rations were selected at random from Hoard's Dairyman.

For Cows Weighing 1,000 Pounds.

Milk-Yield		Digestible Nutrients Required		
Daily Amount lbs.	Testing in Fat Per Cent.	Protein lbs.	Carbohydrates lbs.	Fat lbs.
10	{ 3	1.10	8.81	.24
	{ 4	1.17	9.14	.26
	{ 5	1.24	9.47	.28
20	{ 3	1.50	10.62	.37
	{ 4	1.63	11.28	.42
	{ 5	1.78	11.94	.47
25	{ 3	1.70	11.54	.45
	{ 4	1.87	12.35	.50
	{ 5	1.95	13.18	.56
30	{ 3	1.90	12.43	.51
	{ 4	2.10	13.42	.58
	{ 5	2.30	14.41	.65
35	{ 3	2.10	13.35	.58
	{ 4	2.34	14.49	.66
	{ 5	2.58	15.65	.74
40	{ 3	2.30	14.24	.65
	{ 4	2.57	15.56	.74
	{ 5	2.85	16.88	.83
50	{ 3	2.70	16.05	.68
	{ 4	3.04	17.70	.90
	{ 5	3.39	19.35	1.01
60	{ 3	3.10	17.86	.92
	{ 4	3.50	19.84	1.06
	{ 5	3.92	21.76	1.19
70	{ 3	3.50	19.67	1.05
	{ 4	4.00	21.98	1.22
	{ 5	4.46	23.82	1.36

In practice it may also be broadly stated that there should be a certain proportion of coarse fodder, or roughage, to the more concentrated foodstuffs, as grain and bye-products. Haecker's rule giving one pound of concentrated food for every three pounds of milk yield, affords a very useful basis for calculating a ration.

Thus, for a daily ration, 20 to 40 lbs. of roughage, including hay, silage, stover, etc., may be fed with about 8 lbs. of concentrates (consisting preferably of a mixture of a variety of grains) to a cow of average size and giving about 25 lbs. of milk daily. To cows giving daily 35 lbs. of milk, 10 lbs. of concentrates are suitable,

and if the milk contains 5 per cent. of fat, 12 lbs. may be fed. The great milkers are often fed 30 to 40 lbs. of roughage with 15 to 16 lbs. of a grain mixture daily.

Some such rations as the following may be used for milk cows of average weight and giving about 25 pounds of 4 per cent. milk:

Roughage, 20 lbs. of timothy hay, with a mixture of oats, 2 lbs.; bran, 4 lbs.; and gluten, 4 lbs. This contains as follows: Dry matter, 26.3 lbs.; digestible nutrients—protein, 2.18 lbs.; carbohydrates, 13.09 lbs.; fat, 0.58 lbs.

Roughage, 20 lbs. of timothy and clover-hay, with a mixture of oats, 4 lbs.; barley, 3 lbs.; and oil meal, 1 lb. This is equivalent to: Dry matter, 24.3 lbs.; digestible nutrients—protein, 1.88 lbs.; carbohydrates, 12.1 lbs.; fat, 0.6 lbs.

Roughage, 30 lbs. of ensilage and 10 lbs. of clover hay, with a mixture of barley, 4 lbs., and bran, 4 lbs. This ration is equivalent to: Dry matter, 25.5 lbs.; digestible nutrients—protein, 1.92 lbs.; carbohydrates, 11.92 lbs.; fat, 0.56 lbs.

Roughage, ensilage, 30 lbs., and oat hay, 30 lbs.; with mixture of ground rye, 4 lbs., and gluten feed, 4 lbs. This feed is equivalent to: Dry matter, 23.56 lbs.; digestible nutrients—protein, 2.08 lbs.; carbohydrates, 13.32 lbs.; fat, 0.54 lbs.

It will be seen that the protein is a little low in all these rations, according to Wolff's standard of 50 years ago, but not according to the Wisconsin standard of Haecker.

The best nutritive ratio for milch cows is still a matter of dispute. The Wisconsin standard calls, for each 1,000 lbs. of live weight, 2.15 lbs of protein and sufficient fat and carbohydrates to give a nutritive ratio of 1:6.9. The Storrs station suggests the same amount of protein as Wolff (2.5 lbs.), but an increase in fat and carbohydrates enough to make the nutritive ration 1:5.6.

There is, however, a concensus of opinion favoring increasing the proportion of protein in the food for cows having large milk yields. Dr. Lehmann's standard for milch cows per 1,000 lbs. live

weight, with different milk yields, is as follows. It will be noted that the proportion of protein is higher than Haecker's standards.

Milk per cow per day. <i>Pounds.</i>	Protein. <i>Pounds.</i>	Fat. <i>Pounds.</i>	Carbohy- drates. <i>Pounds.</i>	Nutritive ratio.
11	1.6	0.3	10	1:6.7
16	2.0	.4	11	1:6.0
22	2.5	.5	13	1:5.7
27	3.3	.8	13	1:4.5

Cottonseed (or linseed) meal is one of the richest foodstuffs in protein we possess, and may be added to advantage to bring up the proportion of protein in the ration, as one pound of the meal is equivalent to about one-third pound of digestible protein. Not more than two to three pounds daily of cottonseed meal should be fed, however, on account of its poor digestibility in considerable amounts, and because in excess it may render milk unfit for use as an infant food.

The following mixtures of concentrates may be employed with an appropriate amount of roughage (if hay is used, as much may be given as the cow will eat without waste) as daily rations for an average cow:

Bran, 4 lbs.; corn chop, 3 lbs.; oil meal, 1 lb. Or, 2 parts bran; 2 parts ground oats; 2 parts gluten, and 1 part oil meal, giving 8 lbs. of the mixture daily. Or, 4 lbs. oats; 3 lbs. bran; 1 lb. oil meal. Or, 4 lbs. of bran and 4 lbs. of oats; or, a mixture by weight of bran, 3 parts; gluten feed, 2 parts; corn chop, 2 parts; and oil meal, 1 part, giving 8 to 10 lbs. daily. Professor Haecker estimates that a ration containing seven-tenths of a pound of digestible protein, 7 lbs. of digestible carbohydrates and one-tenth of a pound of digestible ether extract (fat) is ample for the physical maintenance of a cow weighing 1,000 lbs., not giving milk or subjected to other demands. A ration having the proper proportion of nitrogenous to non-nitrogenous nutrients, or, in other words, the proper nutritive ratio, according to Wolff, is now called a balanced ration. Oil

meal is linseed meal. The exact amount of fat in the daily ration is not of much moment, but we should endeavor to approximate Wolff's feeding standard with the more recent modification of adjusting the ration somewhat to the quantity and richness of the milk-yield. An amount of salt equal to one teaspoonful should be given with the feed of each cow twice daily.

Cows may be watered to advantage twice daily; once before they are turned out for pasture or airing, in the morning, and again before the evening feeding. The best method is to always have water before the cows. The greater amount of water cows drink, the greater their milk-yield—within certain limits.

The matter of a pure water supply in the pasture, farm and dairy is of great significance. This is the case, not because the milk is contaminated by germs or poisons swallowed by the cow in impure water, but because the cow's udders become contaminated from wading in impure water. The dairy utensils may likewise be contaminated by washing them in an infected water supply containing the germs of typhoid fever or dysentery. The presence of pools of water in pastures which in any way can be polluted with human excrement or urine should be avoided. Germs or micro-organisms existing in stagnant pools in pastures may impart a fishy taste to milk when such water is wallowed in or swallowed by cows. Water for cattle and for dairy purposes is best obtained from a public water supply of known purity, but when this is not possible a spring, away from sources of pollution, or a driven well, may afford excellent water. Cows do not like very cold water. Avoid giving it to them when possible. The neighborhood of a privy or manure pile should always be shunned, and surface drainage of any kind should be prevented from entering the well. Below the depth of three and one-half feet germs do not live in the soil. Where there is any doubt—and some doubt must always exist concerning open wells and those situated near dwellings—a half gallon of the water should be submitted to a competent chemist for analysis. Wells

must be free of all solid objects, even stones, and water containing over 100 germs to the cubic centimeter is unfit for dairy purposes.

Sedgewick states that if more than 100 germs to the c. c. are present in water it should be regarded as suspicious; and if there are over 500 to the c. c. water should be considered polluted. Wells should not be nearer than 50 feet to any source of infection, and should be walled, surrounded by a coping and covered. Suspected water should be boiled.

If springs are employed, these should also be walled about and covered, with a pipe leading the water for use from the spring. No open water supply is permissible. So steps leading down into a spring may contaminate the water by the feet or drainage from the surface. Cisterns may be used. They should be divided by a porous brick wall so that the water will filter through into the half from which the supply is to be pumped. An arrangement preventing the water first flowing from a roof in a rain from entering the cistern should be made.

The kind of food and manner of feeding cows has an influence upon milk which is of much importance, especially when the milk is to be used by infants.

Many chemical substances in the food are eliminated—either changed or unchanged—in the milk, and may impart to it an unnatural odor, taste or appearance, and may render it unfit for food. A sudden change from dry fodder to grass, or any other green food in considerable amount, is apt to give rise to milk which will cause digestive troubles in babies.

Fresh corn fodder in considerable quantity, when fed to cows, will often render the milk harmful to infants. While roots and ensilage are commonly said to produce a milk which will disagree with infants, yet I believe these are harmless when fed in moderate quantities and after milking.

Silage should not be given in a greater amount than twenty pounds daily, and not more than two pounds of oil meal should be

fed, when the milk is especially intended for infants' use. The feeding of spoiled, moldy ensilage, and remnants of ensilage which have been allowed to accumulate about the barn, are chiefly responsible for the harm this foodstuff inflicts upon milk. In fact, some authorities say that a ration of under 40 lbs. daily per cow is not damaging to milk. Some of the largest buyers of milk in the United States, however, refuse milk from ensilage-fed cows, and those versed in the use of milk for baby feeding find that a small feed of ensilage is safer. The only real objection to silage feeding lies in the use of sour and moldy ensilage and in feeding such large amounts that the cows have diarrhea. In the latter case it is impossible to keep either cows or premises clean. Any sloppy or green fodder which produces diarrhea is therefore to be avoided. When certified milk is produced there should never be any sudden change in the ration, as the composition of the milk may be thus suddenly altered. When the feeding of ensilage is begun in the autumn very small quantities must be given at first and the quantity should only be gradually increased—if the milk is intended for infants' food. Otherwise the milk will be likely to cause vomiting and diarrhea in babies. The same remark applies to the use of corn stalks in summer. They should not be fed to cows until after the corn is in blossom and then only in small quantities at the beginning. Grass, hay, clover and grains have been considered the best food for cows supplying milk for use by babies, but a moderate ration of silage is allowable. The melting point of butter may differ according to the feed of the cows. Gluten products and gluten meal tend to produce a soft butter, while cotton seed meal tends to make a hard butter. Barley and peas in grain mixtures give rise to a softer butter than cornmeal or wheat bran with cotton and linseed meal.

The time of feeding is a matter of great moment. In general, it may be said that milk cows should only be fed after milking to avoid dust in the barn, and fodder, when given at this time—as

mangolds, turnips, rutabagas, carrots or their tops—will not impart a bad odor or taste to the milk. Turnips, turnip tops and rutabagas are excluded from the ration by some milk buyers. A turnip taste, however, is frequently due to germ contamination. It is not necessary to feed cows in order that they be quiet during milking; they can soon be habituated to being fed after milking. Indeed, so great is the danger of disseminating germs in the air when cows are fed before or during milking, that it is now recognized that when dry fodder is thus fed it is impossible to secure clean milk. Moreover, when hay is kept in mows open to the cow-barn, it is very difficult to produce clean milk. If feeding is done at milking time, it should only be moistened grain.

Of 26 samples of hay examined at the Storrs Experiment Station, it was found that on the average a gram (quarter teaspoonful) contained 16,800,000 bacteria. Seventy-two per cent. of these were liquefiers and ten per cent. were spore-forming bacteria. The latter cannot be killed by boiling in the spore-forming stage and therefore exist in pasteurized milk and lead to its decomposition.

The liquefiers cause digestion of the milk and destroy the casein. The varieties of bacteria in hay, which are very numerous, diminish with storing; the miscellaneous acid bacteria double with storing in the barn, but the liquefiers diminish one-third. Hay dust is one of the chief sources of germ contamination of milk. True lactic acid bacteria are not found in hay and therefore it is not the source of them in milk. Hay should be moistened before it is fed.

There are certain pasture plants which are harmful to milk, and sometimes to human consumers of it. Among these are the following: Poison ivy, lupines, wormwood, poison oak, meadow saffron, Jamestown weed, sorrel, poisonous mushrooms, wild mustard, carrot tops, milkweed, sumach, henbane and skunk cabbage.

* Bull. 51 Storrs Agric. Exper. Sta. 1908.

The disease known as milk sickness, or trembles, which sometimes attacks man, has been attributed to the drinking of milk from cows feeding on poison ivy, mushrooms, etc. It is now known that trembles is probably caused by a special germ (*B. lactimorbi*), as it may be reproduced indefinitely by feeding the flesh of diseased to healthy animals. Night exposure is most dangerous to animals—perhaps because the germ is introduced by a biting insect. Cows usually do not sicken with trembles while they are regularly milked, although, without seeming sick, such infected animals may be capable of giving the disease to man drinking their milk. If milking is stopped the cow may suddenly sicken. Cattle with trembles show dulness and weakness, and tremble, pant, and run against objects. Fever is absent. The bowels are constipated but sometimes loose with discharge of blood and mucus. The animal lies with the head to one side and the breath is strong with acetone. Animals finally lie quivering and may be unable to rise. The disease is quite fatal in man and animals. From three to six days after drinking milk from cows affected with the disease, symptoms appear in man. It begins with malaise, vomiting, constipation, pain in the belly, acetone breath and thirst. Twitching of the muscles, weakness and paralysis, with difficulty in breathing, may occur. About half the cases die. The disease lasts about a week or ten days. It is only known in the United States—especially in newly settled parts of the Southern and Middle States. Meadow saffron consumed by cows may lead to severe diarrhea in man drinking their milk.

Milk is not of good quality for any purpose when the animals yielding it are fed upon swill, brewers' grains or food in a state of marked fermentation or putrefaction. Such milk may cause digestive disturbances in man—particularly in babies—and the manure is very soft and stinking from cows eating fermented food, and splashes about, and is therefore more apt to soil the cow and milk. The milk produced with brewers' grains does not keep sweet so long as good milk should, neither are the cows consuming large

quantities of it long-lived. The use of this food is now prohibited by law in most cities. Dried brewers' and distillers' grains constitute wholesome food for cows. Moldy hay, straw or grain; decayed leaves, salt hay, onions, garlic and cabbage may give to milk a bad odor or flavor.

The expressed pulp from the sugar beet is inadvisable as a food for cows, because of its richness in potassium salts, which find their way into the milk and render it unfit food for human beings or animals.

The milk of cows receiving drugs is unsuitable for food, since many medicines are eliminated in the milk. Furthermore, the milk of cows sick in any manner should be withheld from feeding purposes, as poisons in the blood or germs of disease may be conveyed to man or animals in the milk from the sick cow. The milk of cows undergoing the tuberculin test may be used as food unless the animal reacts to the test, when it should be permanently rejected for human consumption, or boiled before feeding it to animals.

CHAPTER V

HOUSING AND CARE OF COWS

IN considering the practical details concerned with the housing and care of cows, and the handling and marketing of milk, our object will be to emphasize the essentials required for the production of clean milk.

Many different methods may be employed to attain the same end, but certain principles are essential. Ideal methods are unfortunately expensive, and the most approved appointments of the modern stable and dairy rival those of the surgeon's operating room in elaborateness and cost. Nevertheless, milk which will fulfil all the requirements necessary for "certification" can be produced by care and cleanliness in an ordinary stable, and without any great outlay for plant.

The Barn

The essentials are that it shall be clean, light, airy, free from dust, flies and odors. In regard to the air space in a barn, this is a matter which depends wholly on the ventilation. When the ventilation is good, 500 cubic feet of air per cow is sufficient, as the air is in constant movement. The number of cubic feet of air, rather than air space, is the important matter. The King system for stables is that commonly used, the principle being to secure a current of air traveling at the rate of 200 to 500 cubic feet per minute through the barn.

The animal's heat is used to aid the movement of air. If the stable is too high, the animal-heat will be lost, so that in cold climates a height of 8 feet is sufficient, while a good width for a

stable is 36 feet. The cows are to be placed in two rows running the length of the stable, and either facing each other or toward the outside of the building. There is much disagreement as to which arrangement is the better. If the cows face outward, there should be feeding alleys in front of them at least 6 feet wide, while the central aisle in the barn behind them is used for removing manure. If the cows face inward, the central aisle between the rows of cows is used for feeding purposes. In either case an overhead railway is often used for removing manure from the centre aisle, when the cattle face outward, or for carrying feed when the animals face toward each other. The writer gives the preference to the plan of facing the cows towards the outside of the building. By this arrangement the cows get more air and light, and their breath does not commingle. At the same time the manure can be more readily removed, which is more important than ease of feeding, for the production of clean milk. In the cow stall, the chief object should be to have an arrangement which keeps the cows wholly apart and does not cumber the floor so as to make places where dirt can collect. The best floors are of concrete, covered with cement, and made somewhat rough, so that the cattle will not slip. Competent dairy men place layers of tar paper under the upper layer of cement,* or cover the cement with movable wood flooring, under the cows, to prevent them from lying on this hard and cold substance. (See Appendix.) If not of cement, the floor should be of planed, matched planking, and the cracks filled in with tar. In case planking is used, it is best at any rate to have the gutters of cement.

To secure drainage of the floor of the stall, the rear half of it—that is, the half nearest the manure trench—should have a fall of two inches. The manure trench should be sixteen inches wide

* On top of three inches of concrete, place three layers of building paper. Coat the two lower layers of paper with melted tar. Add three inches of concrete above the paper.

and about eight inches deep. The trench should have a fall for drainage, being, for instance, six inches deep at one end and ten inches deep at the other; or the whole floor of the stable may be made to slope, with the trench of the same depth from end to end.

Special milking barns (used only for milking) are not at all necessary to produce clean milk, since bacteria are as few in milk withdrawn in ordinary clean barns as in milk withdrawn in barns used only for milking purposes.

Stables should be cleaned by daily scrubbing with a washing compound followed by the use of the hose.

A number greater than forty cows is not desirable in one barn. There should be a continuous window space along each side of the barn. The windows may hinge from below, or be made to open and close as one, by means of a continuous rod. In cold climates, the sides of the barn may be built of two layers of inch, matched boards with a space of eight inches between, filled in with cut straw or sawdust. Besides this, building paper should be laid inside each layer of the boarding. The inner layer of boarding should be without beading and laid perpendicularly. The ceiling overhead should be perfectly tight. If it is composed of a double floor with building paper between, there is no reason why hay should not be kept overhead, providing it is brought down into a room separate from the main stable. There should be tightly-fitting double windows in winter in cold climates. The King ventilating system consists of numerous flues on all four sides of the building for the intake of air, 4 x 4 inches in diameter, and opening three or four feet below the ceiling outside the stable, and entering the stable just under the ceiling. These are furnished with sliding doors, or closed with an arrangement like a furnace register in a dwelling house. The out-take for air should be only one for every twenty cows or less, being a shaft with openings—the same size as the shaft one foot above the floor and just below the ceiling. This shaft should be placed on the outside of the centre of one side

of the barn, and should be carried straight upward like a chimney, six feet higher than the top of the roof.

The shaft or flue should be absolutely air-tight, and may be made of metal, covered with building paper, or preferably of two layers of wood, with filling of sawdust or building paper between, and covered with a cap, to keep the rain out, one foot above the top. The openings near the floor and at the ceiling should be provided with doors or dampers of some kind. The number of flues and size of flues are governed by the number of cows in the barn. Only one flue is necessary for the out-take of air when there are less than thirty cows in the barn.

1 flue	1 ft. square	for	6 cows.
1 "	1 x 2 "	" "	10 "
1 "	2 x 2 "	" "	20 "
2 "	2 x 2 "	" "	40 "
3 "	2 x 2 "	" "	100 "

The movement of air in the ventilating system is brought about by the following forces: Wind pressure against the barn, forcing air into the building; wind suction on leeward side, tending to suck air out; wind blowing across top of ventilating shaft, tending to suck air out of it; by difference of temperature between the air inside and that outside the building. Thus air enters the intake near the ceiling and is distributed over the building. The air at the bottom of the barn is the coldest. In cold weather the bottom opening of the out-take shaft should be open, and the upper opening near the ceiling shut. The cold air is then sucked from the floor of the barn up the flue into the outer air. In hot weather the upper opening in the out-take flue may be opened, and the lower closed. This permits of escape of heated air from the stable, and may be done at any time to secure better ventilation, but at the expense of the animal heat. In order that the system work well, it is essential that every part of the barn be absolutely tight, with well-insulated walls to prevent chilling and condensation of moisture, as about ten pounds of water are eliminated daily from

the lungs and skin of a cow. The doors leading outdoors should be double. There must be no leakage of air in or out anywhere, except through the ventilating system—even hay chutes must be closed, and no escape of air into the loft be permitted. It is not possible to state just how many intake flues there should be, but it is better to have them numerous on each side of the barn (6 feet apart), as they can easily be closed if necessary.

It is feasible to sustain a pretty even temperature in a tightly built stable properly ventilated—somewhere between 55° and 60° F. in cold weather. If the air is too hot, the out-take flues are not sufficient; if too much cold air rushes in, the intakes should be closed to some extent, as there should be no considerable *drafts* when the system is working properly. The intake flues are commonly built in the walls of the barn, and the out-take flues may also be so constructed, in which case they are made of two layers of tight boarding with roofing paper between.

Metal flues are not so advisable in cold climates as wooden ones, because moisture condenses more readily in them. The following sketches of some barns ventilated by the King system are taken from King's "Physics of Agriculture," to which the author wishes to acknowledge his indebtedness for some of the matter concerning ventilation presented above. Old stables can be remodeled with concrete floors, and later the ventilating system, with stuffed walls and tight ceilings, doors and windows, may be added.

Sketch A shows two methods of ventilating a dairy barn. On the right (Fig. 1) the ventilating flue D F rises straight from the floor, passing out through the roof and rising above the ridge. One, two or three of these would be used according to number of cattle. The flues should be at one or the other side of the cupola rather than behind it. On the left C E represents how a hay chute may be used also for ventilating flue. In each of these cases the ventilating flue would take the place of one cow. This method would give the best ventilation, but has the objection of occupying

valuable space. C, in the feed chute, is a door which swings out when hay is being thrown down, but is closed when used as a ventilator, the door not reaching quite to the floor. To take air into this stable, if it is built of wood with studding, openings would

Fig. 1.

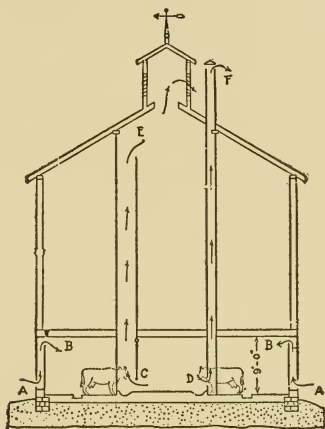
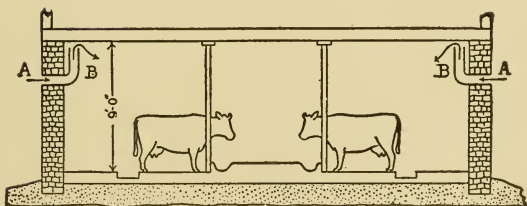

Fig. 2.



Sketch A—Two methods of ventilating a dairy barn.

be left at A about 4 x 12 inches every twelve or sixteen feet, and the air would enter and rise between the sheathing of the inside and the siding on the outside, entering at B as represented by the arrows. Fig. 2 shows intakes through a brick wall.

Sketch B shows a method of ventilating a lean-to stable. The air enters as represented by the arrows at A B and passes out through a flue built on the inside of the upright or main barn. This flue may rise directly through the roof or it may end at E as shown in the figure, the air passing through a cupola. If the upright barn has a balloon frame, then the space between the studding could be used as ventilating flues. These flues could be made tighter by covering inside and out on the studding with the lightest galvanized iron.

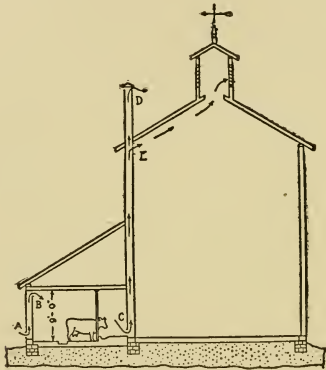

Sketch B—Method of ventilating a lean-to stable.

Sketch C shows a section of the cow stable of the dairy barn at the Wisconsin Experiment Station. A single ventilating flue D E rises above the roof of the main barn, and is divided below the roof into two arms A B D, which terminate at or near the level of the stable floor at A A. These openings are provided with ordinary registers, with valves to be opened and closed when desired. Two other ventilators are placed at B B, to be used when the stable is too warm, but are provided with valves to be closed at other times. C is a direct 12-inch ventilator leading into the main shaft, and opening from the ceiling, so as to admit a current of warm air at

all times to the main shaft to help force the draft. This ventilating shaft is made of galvanized iron, the upper portion being 3 feet in diameter. The covering on the outside is simply for architectural effect. G F show method of intake of air.

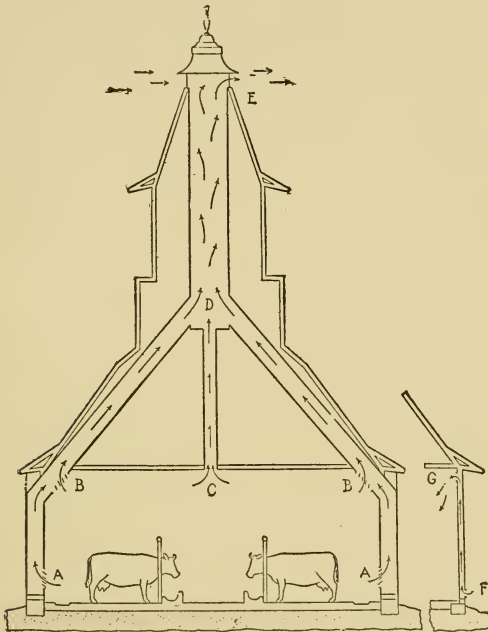

Sketch C—Section of the cow stable of the dairy barn at the Wisconsin Experiment Station.

In mild climates a single storied, high studded (10 to 12 ft.) barn may be best, without the King system of ventilation but with a monitor roof. This resembles a small second story running along the top of the main roof and having numerous windows in its side and ventilators on its top—both to aid ventilation.

The Cloth Method of Stable Ventilation

Quite recently there has come into existence a new system of ventilating barns by means of windows covered with cheap cotton cloth. No method could be simpler or less expensive and the results thus far reported have been very favorable.

Thus Ellis M. Santee, of the Dairy Department of U. S. Bureau of Animal Industry, Washington, D. C., writing in *Hoard's Dairyman* of May 17th, 1907, records some conclusions from exhaustive experiments with cloth ventilation as compared with the King system. He affirms that even with the thermometer registering 43 degrees below zero, water never froze in the barn with cloth-covered windows. Also that the difference in temperature in barns with cloth-covered windows and in those with all glass windows was but 1 to 3 degrees. Moreover, in the stables ventilated with cloth-covered windows, the humidity was 7 to 10 per cent. lower than in the barns ventilated by the King system. Finally he records the fact that many good dairymen have closed the outlets and inlets of their King system to give place to the cloth curtain method. Glass windows to secure proper sunlight (Santee) should be alternated with cloth-covered openings, the proportion being 3 sq. ft. of glass and 2 sq. ft. of cloth-covered openings for each 1,000 lbs. of animal. The cloth should be muslin of the first grade better than cheesecloth, costing 5 to 6 cents per yard.

Some farmers are supplementing the King system of ventilation with the cloth method. This is superfluous if the King system has been properly installed. With the chimney flue in the King system, for creating a draft, there is good ventilation with little air moving along the ground and heat is not wasted in high winds. This is not the case with cloth ventilation. Moreover, if the cloth becomes wet and freezes, ventilation may be nil for the time.

Cheesecloth is now often used in place of muslin and over all the windows of the barn. If fastened outside the windows the glass may be closed when it is so desired.

In summer, mosquito netting—with larger meshes—will give better ventilation.

Some farmers are using cheesecloth the year round on their barns on all windows—having discarded glass altogether—and, it is said, with good results, even in very cold weather. The cheesecloth ventilation certainly proves satisfactory in comparatively mild climates (as the Pacific coast) and is at once so simple and cheap that it may here well supplant the King system and is worthy of trial in colder climates in barns lacking other or satisfactory forms of ventilating systems.

The last word has not been said on stable ventilation by a great deal. Ventilation is a very complex and difficult problem unless one can produce a forced draught of warm or cold air by blowers, as is now done in large public buildings. It has been taught that the impure air (CO_2) falls to the floor in stables and is thus removed by the King system. This is not entirely true, as there are all sorts of currents and counter currents in barns.

One fact is certain, warm air rises. In the dwelling-house warm, fresh furnace-heated air rises and the air containing most CO_2 falls to the floor. In the stable the warm air is furnished by animal heat and the animal emanations must rise to some extent with the warmed air.

If there is only a ventilator on the roof this may allow some warm, vitiated air to escape, but then the current may be reversed by wind pressure and cold air descend. A simple way of securing a constant circulation of air is the Rutherford method, which has been in use for 14 years and is installed in the Dep't of Agriculture buildings at Ottawa. The arrangement is shown in the accompanying sketch.* The inlet is seen at E, D and C,—a U-shaped pipe or box laid in the ground, the deeper the better.

The intake is at E under the covered outside end of the box,

* Hoard's Dairyman, June 5, 1903.

to prevent rain and snow from entering. The diameter of the in-takes should be a little larger than the outlets. They are placed under ground so that the air is of more even temperature and warmed somewhat in winter and is not forced in by wind currents but just replaces that escaping by the chimney. This should be straight and in the top of the roof and contain a damper, F. By closing the damper air ceases to enter or escape from the ventilating system. This may be done when there are very few cows in the barn or in extremely cold weather. The chimney may be made

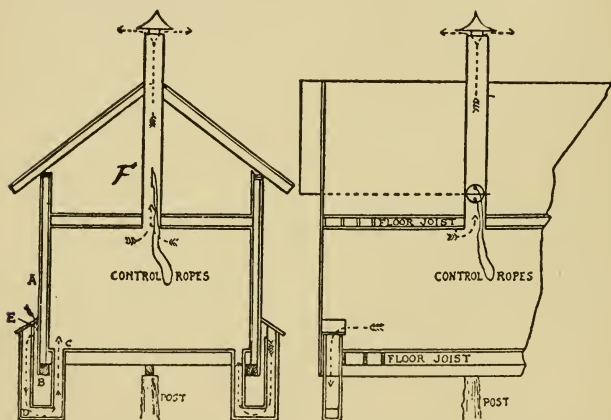

Sketch D—Showing the Rutlerford System of Ventilation. (Hoard's Dairyman.)

of a metal pipe surrounded with sawdust and enclosed in a wooden box, to prevent moisture forming on the pipe. The diameter of the chimney pipe should be about 2 ft. for 20 cows. In warm climates there is no need for any method of stable ventilation other than open windows and doors.

Cow Stalls

It is generally considered of advantage to be rid of stanchions and tie-ups of all kinds, and confine the cow in a stall giving entire

freedom to the head. The swing stanchion, however (p. 87), allows of much freedom of movement and is a good form of tie. The partitions between the cows are made in the form of metal or wooden gates about five feet high, but not touching the floor. The cows are held in place also by a chain or rope fastened by snap hooks to the uprights at either side of the back of the stall, and in front there is a movable partition of metal or wood adjusted to the length of the cow, so as to keep her standing well back to the edge of the manure trench. The whole length of the stall is six feet to six feet eight inches, according to the length of the cow. The cow is fed off the floor, or from a gutter cut in cement inside of the front partition. Metal stalls are comparatively expensive. The chief object is to keep all of the stall structure off the floor, as far as may be, to have a clean floor-space free from nooks and crannies to harbor dirt and dust. The width of the cow stall varies between thirty-eight to forty-five inches, according to the size of the animals. The milker opens the gate of the stall just behind him when milking, which gives him more room and keeps the next cow away from his back.

When the cows are let out the chains may be retained in place and the gates are opened. For details and illustrations of serviceable stable arrangements, see Appendix.

It is well to round up the cement floor to a point six inches or so up the wall of the stable. The urine should be drained into a tank, which can be emptied once or more daily, or be received into a regular drain with a trap. If the urine cannot be so removed it is well to have the gutters tight (without outlet) and use rotted sod, sawdust, or leaf mold to absorb the moisture and save the fertilizing properties of the urine. Chains or ropes should be stretched lengthwise with the stable under the cows' necks to prevent them from lying down after grooming and before milking. The manure must be removed as soon as it falls, except one-half hour before or at milking time, and carried not less than several hundred feet from the barn, so as not to attract flies. When this is not feasible, by us-

ing absorbents, as above, and occasionally sprinkling 5 per cent, creolin solution in the gutters (if of wood), the stable may be kept clean. Sprinkling woods ashes and slaked lime in the trenches daily after removal of manure, is of service. The germs of tuberculosis escape from the tuberculous cow chiefly in the manure and in this way contaminate the milk—unless great cleanliness is used. Thus, in 24 cows apparently healthy, but shown by the tuberculin test to be tuberculous, Schroeder found 40% were expelling tubercle bacilli in the manure; while 6 cows, sick some 3 years with tuberculosis, were all thus expelling tubercle bacilli. This is still another reason for the avoidance of contamination of milk with manure. The dried manure containing tuberculous germs floats about in the dust of a barn and infects healthy animals which breathe it in.

Experiments performed at Washington show that baboons fed milk from tuberculous cows develop tuberculosis almost as rapidly and as certainly as when tubercle bacilli obtained from a tuberculous human being are injected into the animal. This proves that the baboon—and presumably man—is as susceptible to the bovine as to the human type of tuberculosis germ.

Flies convey germs to the milk and annoy cattle. The average number of bacteria carried by each fly is about one million and a quarter, as shown in the examination of 414 flies for bacteria at the Storrs Experiment Station (Bull. 51). Where there is a pig pen or exposed manure pile the proportion of harmful bacteria (*coli-aerogenes* type) is very large. In fact, flies are the chief source of the contamination of milk with the latter type of germs, and these are the cause of diarrheal diseases and infant mortality. Therefore, to prevent infant mortality, attack the fly and prevent its contact with milk. Many of the preparations for spraying cows with the purpose of keeping off flies are of great service, and are widely advertised in the agricultural journals. Shutters are useful in hot weather to darken the stable and, with netting, aid to keep

out flies. Water may be run in the feeding gutter of cement floors, before feeding time, or supplied in iron vessels raised from the floor.

Before sweeping the barn floor it should be sprinkled to avoid dust, and neither sweeping nor removal of manure should be done within half an hour of milking—to prevent contamination of the air. While most of the germs in milk come from dirt on the cow, nevertheless there is also danger of contamination from dust in the barn. For this reason a good way is to keep a barn, built with cement floors, entirely for milking purposes. The floors are sprinkled and the cows only driven in the building at milking time and removed immediately after. In the air of the ordinary barn germs are fifty per cent. more abundant, owing to the dust in the air, than in a school room at the close of the day.

It is advisable to have a number of box stalls for sick animals, for cows about to have calf, and for calves. These should be in a separate stable, because contagious diseases may thus be kept away from the rest of the herd, as contagious abortion, for instance.

A milk receiving room in the stable is useful, in which the milk from separate cows may be weighed and recorded before the milk is carried to the milk room. (See Appendix, page 320.)

The most suitable bedding for cows in the production of clean milk consists either of shavings from kiln dried lumber (which have, in the process of kiln drying, been sterilized), or sawdust, or straw.

We have been laying down ideal rather than the essential requirements in the housing of cattle to secure clean milk. Suppose we take an ordinary barn. The hay is probably stored over the cows. If this is so, then either the hay must be removed, and also the ceiling over the cows, or the ceiling must be made dust-tight and the hay never removed before milking time, to avoid dust. It is probable that there are not enough windows. More windows, or, better, a continuous row of windows, should be put in. There will

be also probably unnecessary feed boxes which cannot be readily cleaned, rubbish and implements and dirt to be removed.

Everything which may collect dust or dirt should be done away with. The whole premises then should be washed, swept and painted or whitewashed. The material sold in the form of a powder and known in the trade as water paint, and which is mixed with water by the user, is not much more expensive than whitewash and is infinitely better. The floors of the cow stalls must be smooth and tight, to be kept clean, and may be of matched wood—although the gutters are preferably of cement. The floor of the stall must not be too long or too short, so that the cow when up will just stand on the edge of the gutter. If the cows are of different breeds and sizes this may be regulated by arranging the ties at proper distances from the gutter. It is well to have a sufficient space behind the gutters, so that one can walk without being soiled with manure, five feet at least, and in some stables this space is made wide enough to drive a wagon for filling with manure. This, however, is not necessary, nor the best way to remove the manure, as it should not be allowed to collect at all. The gutters must be deep enough (eight inches or more) to keep the cows clean when lying down, or may be made six inches deep at one end and ten inches at the other end of the barn to secure a fall for flushing them out with water. They should be made watertight. It is well to keep land plaster or lime always in the gutters to absorb odors. Extra ventilation may be added by installing one of the systems described above without great expense.

Feeding should only be done after milking. A sufficient supply of hot and cold water and basins, soap and towels should be provided in a convenient place for the milkers to wash, and this may be used as a dressing-room. No manure should be permitted to remain within several hundred feet of the barn, and the ground about the barn must be kept clear of rubbish, dirt and stagnant

water, and sprinkled when very dusty. Children and cats and dogs must be excluded from the barn at milking time.

The essentials in relation to the stable, then, are: Sufficient pure air and light; freedom from dust; clean floors, gutters, walls and ceilings; and clean surroundings, free from manure and rubbish.

Care of the Cows*

All cows should be tested with tuberculin† before their milk is used for human consumption, either as raw milk or in the form of cream, butter or cheese. This is necessary, since no expert can tell positively by the appearance or examination of a cow whether she is tuberculous or not in many cases. A tuberculous cow may even be very fat. If tuberculous cows are found in the stable it must be thoroughly cleaned and disinfected after the diseased cows are removed and before healthy animals are placed in the stable (see p. 346).

Before adding new cows to a herd it is safer to test them with tuberculin twice; once before purchase and again after three months of isolation from the herd. Then if the cows fail to react they may with safety be added to the herd. Sometimes cows which fail to react in the first test may communicate the disease to the herd if at once turned loose with the herd before a second test. The necessity for this double test with tuberculin depends upon the fact that animals may not react in a very early or latent stage of tuberculosis and again that animals receiving treatment with tuberculin in increasing doses before their sale may not at that time react to an ordinary test dose. New cows subject to the double tuberculin test and isolated may still supply certified milk after the first negative test.

The germs of tuberculosis have been frequently found in milk, cream, cheese and butter. (Butter may harbor active tubercle bacilli for five or six weeks.) The bacilli of tuberculosis will retain their

* See Moak's "Card for Identifying Cattle," p. 357.

† For directions for testing cows with tuberculin, see p. 347.

virulence in ordinary salted butter for four and a half months or longer; in cheese, 30 or 40 days, (Schroeder & Cotton) and as tubercle bacilli are found in about one-fourth of samples of separator slime the reasonable inference may be drawn that they occur with the same frequency in the cream from which the butter is made and therefore in 25 per cent. of butter.

The danger of consuming milk from tuberculous cows is seen more conspicuously in children. In 20 cases of primary tuberculosis of the bowels and mesenteric glands, in children, 13 were caused by the bovine germ of tuberculosis and 7 by the human type of the tuberculosis germ. In 16 children with tuberculous glands of the neck, 10 of the cases could be attributed to the human type of tuberculosis germ and 6 to the bovine form. In 140 cases of tuberculosis in human beings, 21 or 15% were derived from a bovine source (Steffenhagen). The distinction between tuberculosis germs derived from bovine and human sources is made by studying the characteristics of the germs during their growth outside the body upon special culture media, and also by the injection of the germs into animals. The bovine bacillus of tuberculosis when injected into cattle and the lower animals is much more virulent than the human type.

Recent experiments from many sources (German Commission and British Royal Commission on Tuberculosis, etc.) appear to show that in tuberculosis of children respectively, 10 and 23 per cent. of the cases are due to the tuberculosis germ peculiar to cattle (Bovine tubercle bacilli), thus locating the origin of 10 to 23 per cent. of children's tuberculosis in milk.

In the light of most recent scientific studies and experiments, tuberculosis in man appears to start more frequently in the digestive tract than was formerly supposed even when the disease is situated only in the lungs and other parts of the body. No cow should be placed in a herd until it has been tested and found free from tuberculosis. Such testing must be repeated once a year, or twice, if there

has been much tuberculosis in the herd. One tuberculous cow may infect the entire herd. While one has tuberculous animals they should be kept in a separate barn from healthy animals. According to the present New York State law tuberculous cows may be kept under restrictions according to what is known as the Bang system. That is tuberculous cows are kept in a separate stable and their calves removed, as soon as born, and fed on the mother's milk after it has been pasteurized at 185° F. These include animals which are only known to be diseased because they react to the tuberculin test, while those cows are killed which show physical signs of tuberculosis—especially disease of the womb, udder, and lungs in which germs are spread broadcast by discharge from the womb, from udder to milk, and in manure from the blood or from swallowing of discharge coughed from lungs.

When the calves are born they are suckled only for the first day. There should be two sets of barn employees if possible; one for the tuberculous and the other for the healthy animals. Also two sets of barn utensils of every kind. The stock must likewise be separated in pasture and the calves tested every six months with tuberculin. This method is of value when the cows are valuable. Calves should not be allowed in a stable with milch cows as they may spread infection.

The milk of cows which are being tested with tuberculin may be used, providing that they do not react to the test. All cows should be identified by metal tags in the ears containing a number or other mark. Such tags are also necessary to separate those which have been tuberculin-tested.

Cows with garget (having caked udders, or pus (slime) and blood in the milk) should be milked by one who does not milk the other cows, and animals about to calve should be kept apart from the herd. Milk is now condemned in cities which is found to contain an excess of germs (streptococci) and pus from inflamed udders. Diseased udders are more apt to be found immediately be-

fore and after calving and the milk from cows at these times deserves careful watching. In view of the wonderfully successful results from the use of air for inflating the udders of cows suffering from milk fever, it will be wise for the farmer to keep the simple apparatus on hand for practicing the treatment. Every agricultural paper advertises information for obtaining and using the apparatus. Cows with leaky teats are especially subject to bacterial infection of teats and should be removed from a herd supplying certified milk.

The hair about the flanks, udder, and the brush of the tail should be clipped short and the cows groomed once or twice daily, if necessary. The carding and brushing is done after milking, or must be completed two hours before milking, otherwise the dust produced will give rise to an increase of bacteria in the milk. In fact, there will be many more germs in the milk from cows brushed just before milking than would occur in the same milk if the cows had not been brushed at all.

Cows may be washed, however, immediately before milking, provided that they are not so wet as to drip. This should always be done if cows are soiled with manure or urine in a moist state, and, in some certified dairies, all the cows are washed in a special tank for the purpose.

This is not at all essential, and the writer has seen great shrinkage in milk caused by too free use of cold water applied to cows before milking.

Before each milking, the udder should, however, be wiped with a clean, damp towel, or washed, if necessary, with soap and water and dried with a dry towel.

The towels must be clean and the water pure for this purpose. The teats and udder should always be slightly damp, but not wet, during milking. If the udder is dry so much dust and dry skin falls into the milk that the number of germs in the milk is much increased. It is well to tie up the cow's tail to the stall while milking. The tail-holder is useful in fly time. A tail-holder is applied

to each cow before it is milked and at the same time one is also applied to the cows on each side of the cow which is to be milked. The appliance may be obtained of dairy supply firms. Handling the udder stimulates the flow of milk. So that the udder should be cleaned by a man or boy especially devoted to this work, who

Fig. 3.

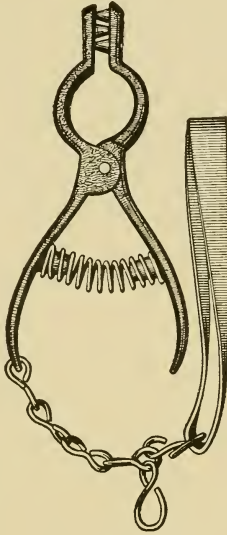

Cow Tail-holder.

The pincers snap around the cow's tail and the rubber band is passed around the leg and hooked into the open link on the chain. (Bull. 104 Bureau Animal Industry.)

goes immediately ahead of the milker with pail of warm water, wash cloth, soap and clean towels. He can thus clean as many udders as would require ten milkers to milk. If the udders are cleansed some time before milking begins—as by the milkers themselves—the cows are apt either to leak their milk or to shrink in milk-yield. Do not allow the cows to become excited by hard

driving, abusive treatment or even loud talking. The cow yard should be clean and dry. If it is deep in mud it is impossible to have clean cows.

The best plan is to allow no talking whatever to the cows at milking, and then, when there is a change in milkers, it will not influence the animals so much.

All herds from which a clean milk supply is desired should be examined by a competent veterinarian at frequent and regular intervals. Such inspection will prevent contamination of milk with many of the germs most dangerous to the human consumer, because these germs are derived from diseased cows.

Indeed, veterinary inspection of cows is as much more valuable than laboratory examination of their product, as prevention generally is better than cure. (See p. 178.)

CHAPTER VI

HANDLING OF MILK AND CREAM

Milkers and Other Employees

THE milker should be clean and be clean shaven; hair on the face is inadvisable. Before milking and before putting on his milking suit he must wash his hands thoroughly with warm water, soap and a nail brush. And as soon as the milker has finished milking a cow, and poured the milk from his milking pail over the cooler, he should wash his hands again before milking another cow. The hands must be well dried on a clean towel before milking is begun. Some 45 million bacteria were found on the hand of an ordinary farm worker about 98 per cent. of which may be removed by thorough washing with soap and warm water. (Storrs Exper. Station.)

A special suit of clean, washable outer garments and a clean washable cap should be worn during milking and at no other times. A costume consisting of a white duck cap, duck trousers, and khaki shirt with leather belt, is satisfactory. The suit need not be sterilized, but should be washed twice a week. When not in use they must be kept in a clean and airy place. If milking is done after dark the barn must be well lighted or the milker must carry a lantern. This is very objectionable as the lantern will soil his hands with oil and germs.

Milking ought to be performed at the same hour, morning and evening. Milking must be accomplished quietly; jerking the

teats causes dirt and germs to drop in the milk and is not permissible.* The first few jets of milk from each teat must be rejected (not on the floor, but into a special, clean, sterilized small pail), because the germs are washed out of the milk cistern by the

Fig. 4.



Good type of Milking Suit and Pail. (Bull. 41 Hygienic Lab.)

first part of the milk. If any of the milk in the pail becomes contaminated through accident or through mixture with stringy or

* For more detailed account of milking and use of milking machine, see Appendix, 336.

bloody milk from the udder, the whole must be thrown away. Milking stools must be clean; iron stools, painted white, are recommended (see Figs. 5 and 6), or the use of a milk pail as a seat (see Fig. 9, page 105).

After the milker has donned his milking suit and cap and washed his hands, he should touch absolutely nothing but the cleaned teats of the cow and his clean stool and milk pail. The habit of milkers wetting their hands with milk is not to be tolerated.

No person employed to milk, or handle milk in any way, should have, or have come in contact with, any contagious disease. In case of illness in the household of an employee a physician's certifi-

Fig. 5.



Iron Milking Stool.

Fig. 6.

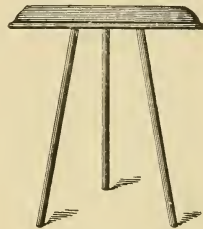

Milking Stool.

cate should be required of the employee stating that the illness is not communicable before permitting the employee to come in contact with milk in any manner.

The safest rule is to debar a person from handling milk who has tuberculosis, syphilis, severe diarrhea, or suppurating sores on the surface of the body, throat trouble or any infectious disease, or has come in contact with a patient suffering from contagious disorder, or entered a dwelling in which there has been contagious disease.

If a cow has one-quarter of the udder inflamed so that pus (slime) or blood escapes from it into the milk, the milk from the whole udder is unfit for human consumption. The cow should be

isolated, and the milk, after boiling for 15 minutes, may be fed to animals.

The milk pail is an important factor in the production of clean milk. The writer first employed a pail which has a removable cover crowned up so that it is about four inches above the top of the pail, with a hole in the cover six inches in diameter. The pail has a spout arising from its upper part and reaching a little above the cover of the pail when it is in place. The spout on the pail is covered by a removable metal cap.

Two layers of sterilized cheesecloth or cotton flannel are placed across the top of the pail and then the cover is fitted on over

Fig. 7.

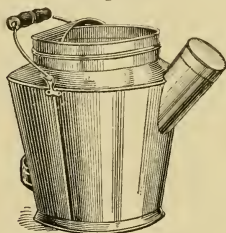

The Gurler Milk Pail.

Fig. 8.

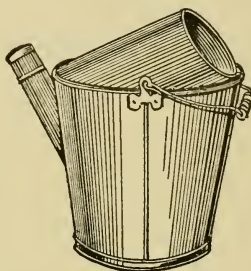

A recent improvement of the Gurler Pail.

the top of the pail, stretching and holding the cheesecloth in place. When the pail is full it may be emptied through the spout without disturbing the cheesecloth, and so be used through a whole milking. The gauze (or flannel) is washed in warm water, then in soda and water, and rinsed in cold water and boiled 20 minutes, or placed in the steam sterilizer before being used again. It is better to use it at but one milking and throw it away. The Gurler milk pail (Fig. 7) is very similar, with a removable cover, the opening in which is larger than it need be, however. Otherwise it is a very satisfactory pail. Cheesecloth is laid over the top of the pail and the

cover is fitted on, stretching it into place. Experiments have shown that milking through a clean cheesecloth strainer is capable of yielding a comparatively clean milk, even in rather dirty premises.

The writer has recently known excellent results with the use of a milk pail modified from one described by Stewart of Philadelphia. This is made of spun steel, $10\frac{1}{2}$ inches high, and is covered with a flat, removable lid on which the milker sits. The milking is done into a spout which has an expanded opening 7 inches in diameter. The spout is covered at the end by a removable pan,

Fig. 9.

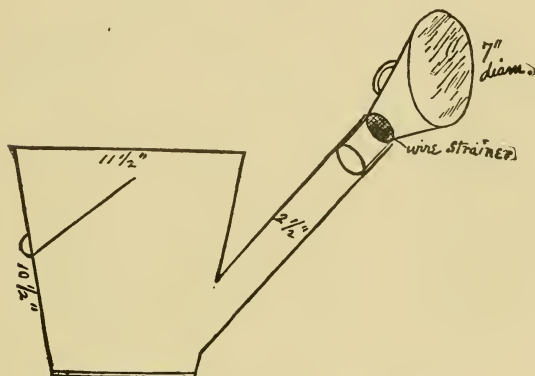

Modification of Stewart's Milk Pail.

and the bottom of the pan is a wire strainer—100 meshes to the inch. The opening of the spout is nearly vertical, so that dirt will not easily fall into it. Any metal worker can make such a pail. Stewart's pail may now be procured of the Star Milk Cooler Co. Stewart found that milk in this pail contained only 29 germs, as against 125,000 germs to the quarter teaspoonful of milk drawn into an open bucket.

Milk pails should have all seams covered smoothly with solder. The aluminum pail is best because made in one piece without joints.

Stocking * gives the following summary of results of experiments with covered pails and strainer cloths:

1. The use of the covered milk pail is of great advantage in any stable in excluding dirt and bacteria from the milk. The relative advantage gained by the use of the cover depends upon the sanitary condition of the stable.

2. The special form of cover does not seem to be important provided it is a device practical for use and the area through which dirt can gain access to the milk is reduced as much as possible.

Fig. 10.

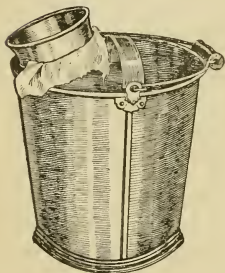

Stadmueller Covered Pail.
(Bull. 48 Storrs Exper. Sta.)

Fig. 11.

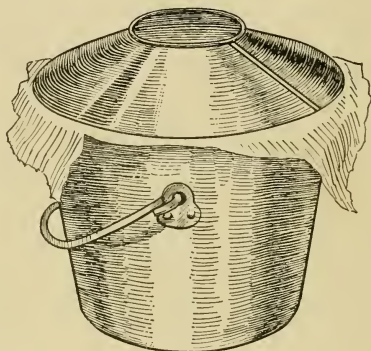

The North Covered Milk Pail.
(Bull. 48 Storrs Exper. Sta.)

3. Whether or not a strainer on the covered pail is desirable depends upon the style of the straining device.

4. The use of the strainer in a pail where the dirt which falls into the opening is likely to be driven through by the succeeding streams of milk is not desirable (Stadmueller, Fig. 10). Its use tends to increase the germ content of the milk and injure its keeping quality.

* Bull. No. 48 Storrs Agric. Exper. Sta.

5. In pails where the dirt which falls in does not remain where the succeeding streams strike against it a strainer cloth aids in keeping down the number of bacteria which gain access to the milk. The North pail (Fig. 11), is an illustration of this type.

6. The use of absorbent cotton as a strainer, as in the Gurler pail, is a decided advantage in preventing the entrance of bacteria into the milk.

The metal strainer is safer where milkers are unreliable, as they will handle cheesecloth strainers and lay them down in dirty

Fig. 12.

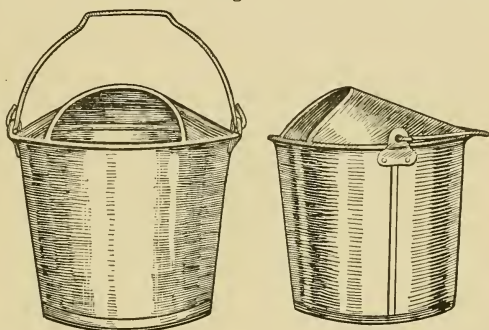

The Trueman Covered Milk Pail. One of the simplest and best covered pails. Made in one piece, easily cleaned and does not have any strainer. (Bull. 48 Storrs Exper. Sta.)

places. Cotton wool (absorbent cotton) laid between two layers of cheesecloth to strain milk—while milking—into the pail, is more effective than cheesecloth alone, but we have found that the cotton wool is matted in lumps by the jets of milk and that only those absorbent cotton strainers made by dairy supply companies for the purpose are to be recommended. We have been content with the good results obtained from cheesecloth alone.

By a new invention one may do away with the small mouthed milk pail and at the same time save the expense and trouble of

changing the cheesecloth filter after each cow is milked. This new appliance is known as the Revolving Dairy Filter (Fig. 13). Briefly, the principle is as follows: There are two parts. 1. A reservoir to catch the milk which may be attached to an ordinary open milk pail. 2. A revolving disc attached to the under surface of the reservoir. The cow is milked into the reservoir and the milk passes through an opening one inch in diameter in the bottom of the reservoir through three thicknesses of cheesecloth and through holes in the revolving disc into the pail.

After each cow is milked the disc is turned by a handle so that a fresh portion of cheesecloth and a new opening of the perforated

Fig. 13.

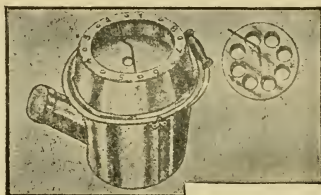

Revolving Dairy Filter.

disc is brought opposite the single 1 inch hole in the reservoir. In this way eight cows may be milked with a fresh filter surface for each cow and using the same milk pail. The opening through which the milk passes is also smaller than in any small mouthed milk pail. As compared with the open pail more than three quarters of the bacilli are removed by this filter. It is readily cleaned and sterilized and is cheap.*

For farmers using little care in cleaning their cows and large mouthed milk pails the revolving filter is certainly to be recommended.

* Revolving Dairy Filter Co., 53 Union St., Portland, Maine.

But, if cows are properly cleaned and their udders dampened before milking, it is probable that a simple Trueman pail is the best pail of all those described and is without any filter whatever. The area on which dirt may fall is somewhat larger (6 in.) in the revolving filter than in a small mouthed pail. Its use also adds another article to cleanse and it is in itself another possible source of bacteria if not perfectly sterilized.

The handling of milk may be conducted properly in many ways. Some of these are very simple and inexpensive; others, which are quite expensive and elaborate, are required for convenience and

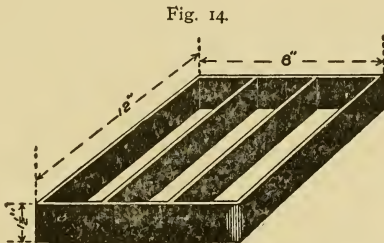

Metal frame on which milk pails are set in the stable to keep them out of the dirt. (Storrs Bull. 48.)

certainty when large quantities of milk are to be handled in the most approved style.

To such a degree of refinement has this matter been carried, and such a multitude of utensils have been devised, that the inexperienced, would-be dairyman is disheartened at the very outset by the great number of appliances which he finds are alike recommended and reviled by his various advisers. The matter of the best way to handle milk is a source of constant study, and improvements are as constantly taking place, and while there will never be a time when competent men will all agree on special details, yet they are agreed on the principles and essentials of the business. We have already described the principles, and dwelt upon the facts which

have led up to the establishment of those principles; we now propose to devote our attention to the essentials in handling clean, pure milk. First: We will consider those essentials necessary to insure the continuance of the cleanliness of the milk until it reaches the consumer, and then the various devices for convenience, labor-saving and system required in handling large quantities of milk in the best manner known at the present time—always with the admitted possibility of improvement in details.

The milk room is the first essential. It must be clean, proof against dust and extreme weather conditions, and separate from barn and house. It need not be expensive or elaborate. The floor, although preferably of asphalt or cement, may be of oiled or painted wood (if smooth and tight), and if on the level with the bottom of the milk wagon, will make it easier in loading the milk.

All water and washings from the room must be carried away in pipes to a point fifty yards from the milk house.

The milk room should be surrounded by grounds free from rubbish, pools of milky water, or dust (fifteen grains of dust have been shown to contain as many as seventy million germs), and should be at least forty feet from the barn.

It must be well lighted, with mosquito screens at the windows and doors. The windows and doors should be closed, as far as possible, at the time the milk is handled in the house, to exclude dust—ventilation being obtained by the King system. If there is a closed porch or vestibule, it will be an added safeguard against the admission of dust in windy weather, by providing an entrance with double doors. The construction of the milk room may be of wood, with walls and ceiling of wood or plaster, preferably painted. Whitewash may, however, be used on the inside of the room and should be renewed every three months. Scrupulous cleanliness must be observed in the milk room, and it should be kept as dry as possible in all its parts, with no spots of mold on the walls. No sour milk should be left in the room, as the sour milk, or lactic acid

germs, will get into the fresh milk. The milk room ought not to be used for any other purpose than to handle the milk, and should contain nothing that is not required in handling milk.

When milk is to be shipped in cans, the following utensils are essential:

Milk pails.

Receiving tank or cans.

A strainer.

A cooler or aerator.

A collecting can.

Shipping can with all seams flushed with solder.

A tank for washing purposes.

A tank for immersing cans in cold water.

Also washing soda or soap powder, brushes to scrub utensils and inside of cans, and cheesecloth for straining purposes.

Pure hot and cold water, and steam if business is conducted upon a large scale.

Method of Handling Milk To Be Shipped in Cans

Cooling the Milk.—I cannot agree with such authorities as Dr. Chapin, of New York (than whom no one has done more to introduce clean milk into that metropolis), when he says on page 131 in his book on "Infant Feeding": "For cooling the milk to best advantage a can placed in ice water is better than the commercial coolers."

Clean milk calls for milk cooled to below 50° F. with an hour. This will not be accomplished by placing milk warm from the cows into large cans and then immersing the cans in ice water, unless by constant stirring of the milk in each can. Warm milk placed in quart bottles and immersed in ice water can be cooled properly—that is, to 45° F.—within the hour. When milk is obtained from cows giving milk varying greatly in composition, as is usually the case, it must be thoroughly mixed before bottling. But, inasmuch as half an hour or more is commonly required to milk sufficient milk to mix, and inasmuch as one cannot keep

warm milk for this period without great increase in germs, the only way is to cool each pailful as soon as it is milked.

Then the milk may be kept an hour or more before it is mixed and bottled. I started out prejudiced in favor of cooling milk by immersion of cans or bottles in ice water, but did not find it practicable, except under certain conditions (see p. 118). There is no doubt but that the cooler and all apparatus, not necessary in handling milk, should be abandoned when possible. The oftener milk touches objects the more likely will contamination result, especially by aeration in a dusty atmosphere. But immediate cooling is essential.

When milking begins, as soon as a milk pail is filled, the milk should be taken directly to the milk house and the milk poured into the strainer, which is placed in the receiving tank of the cooler. The milk runs over the cooler and is received in the shipping can, which, when filled, should be immersed in a tank of cold or iced water above the shoulder of the can with the cover of the can left off until shipping time. The milk should be cooled below 50° F. Two types of coolers or aerators are in common use. Aeration, or exposure of the milk to air, is not essential if the milk is withdrawn from the cow in a cleanly manner, but if the milk is more or less contaminated with manure, by impure air or by odors caused by imperfect feeding, aeration frees it to an extent of so-called animal odor. Aeration is inadvisable, in so far as the milk is exposed to germs in the air during the process. The coolers in ordinary use do, however, aerate the milk at the same time that the milk is cooled. The conical cooler (Fig. 15) may be employed when a moderate quantity of milk is to be handled, but requires more labor, as, in order to cool the milk satisfactorily, the water in the aerator must be constantly stirred to continually change the layer of water lying against the inner surface of the tin over which the milk runs. This aerator is fitted with an inflow and outflow pipe for running water, at either side of the base of the aerator, but

unless the water is near the freezing point, it is better to fill the aerator with cracked ice, salt and water. In this case the aerator may be simply used as a storage tank for ice water, and both the inflow and outflow pipes are closed. By constant stirring of the ice water in the aerator while the milk is flowing, it is possible to reduce the temperature of the milk coming from the cooler to below 50° F. In this style of aerator the milk flows from the reservoir at the top through fine holes all about the base of the reservoir out

Fig. 15.

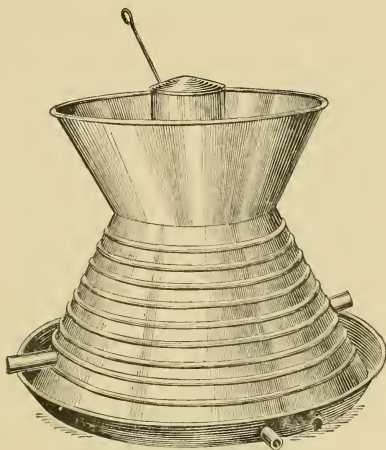

The Conical Cooler.

on to the surface and corrugations of the cooler, collects in the gutter below, and is carried off by the pipe leading from the gutter (in the front of the aerator in the cut) into the shipping can. Often these holes are too large or too numerous, allowing the milk to flow too fast, when some must be closed by solder. This kind of aerator works very unsatisfactorily if the water is not constantly stirred, and is not to be recommended if running water is at command and permits of use of a Star or tubular cooler.

The Star cooler (Fig. 16), or that of the tubular variety (Fig. 17), are by far the most efficient, certain and convenient coolers,

Fig. 16.

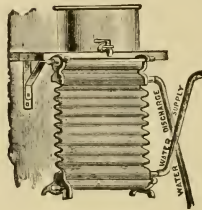

Star Cooler.

although more expensive in first cost than the conical aerators. The much greater surface offered by the tremendously corrugated

Fig. 17.

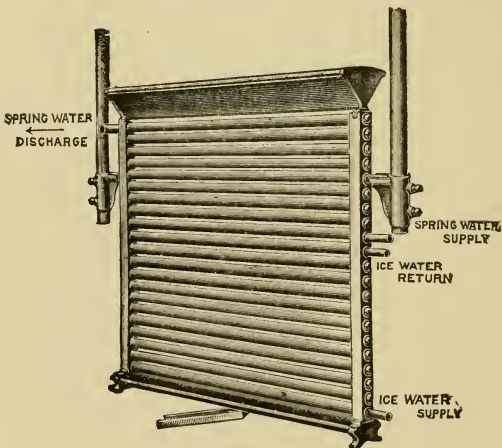

Tubular Cooler.

form of the cooler, together with the forced circulation of water which flows continuously from below upward through the cooler, account for the superiority of this type of cooler.

The temperature of the milk may be lowered to a point two degrees above that of the water circulating through the cooler.

The Star cooler is made of two sheets of corrugated copper, tinned on its outer surface, which comes in contact with the milk. The water enters below, filling the entire space between the copper sheets, and flows upward through the cooler, while the warm milk drops through the holes punched along the whole length of the feed trough at the top of the cooler and flows down over both cooling sheets. As the milk is cooled, flowing down the outside, the water is warmed as it moves up the inside of the cooler (see Fig. 16).

Fig. 18.

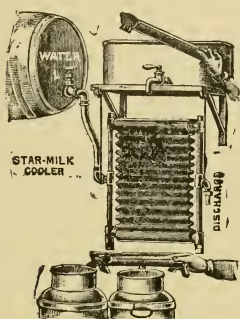

Star Milk Cooler.

Fig. 19.

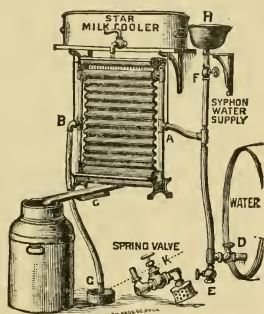

Star Milk Cooler.

The water supply for the cooler may be obtained in various ways: From a common source of water, as a town supply; from a barrel or tank over the cooler (see Fig. 18); or from a barrel beneath the cooler by means of a siphon attachment (see Fig. 19). If it be desired to cool the milk much under 50° , it may be necessary to use ice water in a part of the cooler.

This is most economically accomplished by an ice water section, which is made to be hung on the bottom of the Star cooler and is practically a small counterpart of the larger cooler above

(Fig. 20). Ice water is run through the ice section alone and is obtained from an overhead barrel holding broken ice, over which water is sprayed from a large-surface nozzle, and flows from the barrel through a short hose through the ice water section.

A similar result may be secured by using a tubular cooler (Fig. 17), arranged so the general water supply may be run through the upper half of the cooler, and the ice water or cold brine through the lower half. By either of these contrivances milk may be reduced to a temperature below 40° .

Fig. 20.

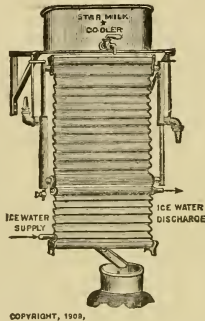

Star Milk Cooler.

In place of the spray-head for sprinkling water on cracked ice in a barrel, to supply the ice water section of the Star cooler, it has been found (by my friend Mr. Paulhamus, of Sumner, Wash.) that the following arrangement is better: A medium-sized cask is lined from top to bottom with a coil of a hundred feet or more of half-inch pipe. The water supply is connected with the bottom of the coil, and the top of the coil is connected with the ice water section of the Star cooler. Large pieces of cracked ice are used to fill the cask to the top, to which may be added rock salt and then water. If salt is used, care must be taken to have the water run-

ning constantly through the coil in the cask, otherwise the water will freeze in the coil. This way of cooling the water supply for the water section of the Star cooler is both more convenient and satisfactory because the cask may be placed directly on the floor of the milk room, instead of up in the air as required for the sprinkler, and much less ice is used than when a sprinkler is employed.

The advantages of such arrangements consist in utilizing the natural temperature of the regular water supply of the dairy to do the chief part of cooling the milk, while the ice water is only required to complete the smaller part of the reduction of temperature in hot weather. There are many different sizes of both the

Fig. 21.

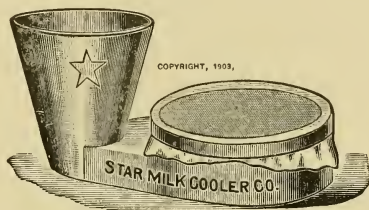

Trap Milk Strainer.

conical, tubular and Star coolers adapted to the quantity of milk which is handled. The tubular coolers are constructed to withstand high water pressure, while the Star coolers are not.

While milk may be simply poured from the milking pails through two or three thicknesses of cheesecloth, or through one layer of cotton flannel, into a receiving can, from which it is transferred to the receiving tank of the cooler, a better form of strainer is the trap variety (see Fig. 21), which is placed in the receiving tank of the cooler. The milk is poured into the upright funnel, and has to rise from below up through the cheesecloth strainer to seek its level.

Particles of dirt and foreign matter would naturally, through

gravity, fall to the bottom of the vessel and not be forced through with the milk, as commonly happens when milk is poured from above through a strainer.

In regard to straining milk. Every additional utensil adds another possible medium for the conveyance of germs to milk. Too great emphasis cannot be put upon this point—*i. e.*, the necessity for the use of as few utensils as possible. When the cows are thoroughly clean it is not essential to have any strainer upon the milk pail at all, and the only straining of the milk may be done through two single thicknesses of sterilized cheesecloth with a layer of sterile, absorbent cotton between these. This straining is done when the milk is poured into a receiving can for mixing the warm milk or into the receiving can of the cooler.

The strainer cloths used over the milk pails and other utensils may be of various materials. The writer has employed chiefly cheesecloth or rather gauze (which is cheesecloth prepared by washing, to remove the sizing and impurities, and dried), of the finest mesh, and two layers in thickness.

A single thickness of coarse cotton flannel or Turkish towelling may be used, however. When the strainer cloth cannot be sterilized in a regular sterilizer, it should be boiled for twenty minutes wrapped in a towel or clean cloth and left enclosed in this wrapping until used. Then it should be removed, but the fingers should not touch that part of the strainer cloth which will come in contact with the milk. Before sterilizing the cloth, it should be well rinsed in cold water, washed in hot water and washing soda, and rinsed in cold water again. Every little detail must be carried out conscientiously, as one failure in caring for the milk properly will spoil the result entirely.

The simplest, cleanest and most inexpensive method of handling milk is to place it—as soon as milked—in a bottle-filler tank and run it at once into bottles and immerse the bottles in ice water. By this method, the need of a cooler is avoided and the chance of

germs getting into the milk during its exposure to the air in running over the cooler. The chief objections to this method are two. (1) That the milk is not cooled so rapidly, and (2) that the milk will not be uniform in composition. The first objection is of no weight if the milk is clean; that is, bacteria will not multiply in clean milk while it is cooling in the bottle.

The objection to lack of uniformity in composition is very real and important. As mixing milk is not done in the bottling tank the cows should yield milk of pretty uniform quality, otherwise the milk

Fig. 22.

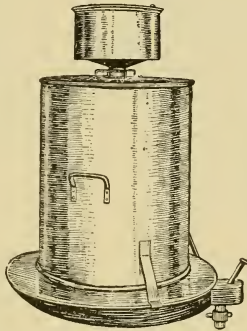

Covered Milk Cooler. (Bureau of Animal Industry, Bull. 104.)

in different bottles will vary very considerably, as the milk is bottled as soon as it is withdrawn from the cows. If there are a number of milkers and the milk-yield of the different cows is similar in composition, then the method is ideal in its simplicity and its freedom from expensive and contaminating apparatus. The milk will be cooled to 45° F. in ice water in an hour and by no method will the cream rise more rapidly. Another method of overcoming the danger of the tremendously thorough exposure to the air of milk passing over the ordinary coolers is the covered cooler and bottle filler (see Fig. 22 and Fig. 23).

This arrangement is particularly applicable in milk rooms which cannot be sterilized by steam and in which the air may be contaminated by dust and germs.

Its simplicity and moderate cost are also attractive features. It is said that one man can fill and cap two to three hundred bottles in one hour with the appliance, and that it is suitable for a herd of

Fig. 23

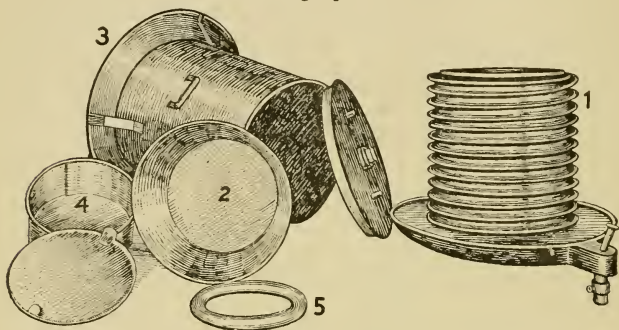

Parts of Cooler.

1. Cooler proper. Water passes through interior of coil, and milk over outer surface. 2. Receptacle placed on top of No. 1; has perforations in the bottom near the edge for distributing milk over the cooler. 3. Cover inclosing cooler. 4. Receptacle for receiving the milk and which also contains the strainer. The latter consists of a perforated plate which is put in first; next to this is placed a layer of cheese cloth, then a layer of absorbent cotton followed by another layer of cheese cloth and a perforated plate. 5. A copper ring, filled with lead and heavily tinned, placed on top of parts of strainer to hold them in position. (Bureau of Animal Industry, Bull. 104.)

fifty cows and should not cost over \$150.00 (Bull. 104, Bureau of Animal Industry). It may be bought of Dairy Machinery and Construction Co., Shelton, Conn.

In Fig. 24 it is shown how the cooler of this apparatus is placed in the weigh room and the filler in the milk room.

Hot Water.—Hot water may be readily obtained at comparatively small expense from a tank, such as is commonly employed

for supplying households with hot water when attached to the kitchen stove, by connecting the tank with a coil of pipe placed in an ordinary air-tight, wood stove. If a steam boiler is in use, the

Fig. 24.

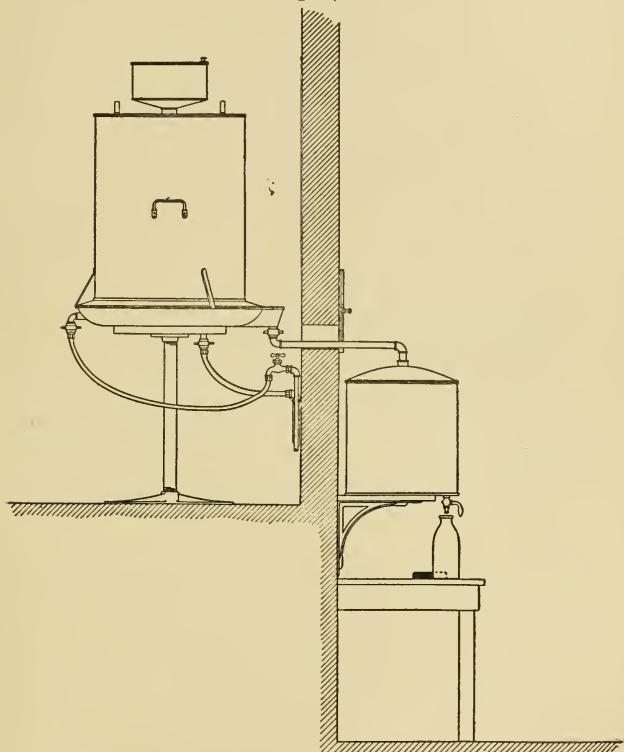

An arrangement of cooler and hand bottle filler. (Bureau of Animal Industry, Bull. 104.)

steam may be run into a tank of cold water. The steam heating tee is a most convenient appliance for heating water (see p. 131). In either case the stove or boiler should be placed in an adjoining room, to avoid dirt, while the tank is in the milk room.

Cleaning Utensils.—After milking, all the utensils, including milk pails, receiving tank, cooler, straining cloths, etc., should be at once rinsed in cold water, then washed in hot water and washing soda (sodium carbonate in 3 per cent. solution), and rinsed again in clean, cold water. Finally, all metal dairy utensils should have boiling water poured over them, which sterilizes and dries them at once. Seamless utensils are always preferable, as offering no crevice for germs to lodge. Dairy utensils should never be dried with towels. The cans should be scalded with boiling water or have live steam turned in them and be placed upside down on bars to drain in the milk room, thus also admitting air. Rusty cans should never be used; they sometimes impart a

Fig. 25.

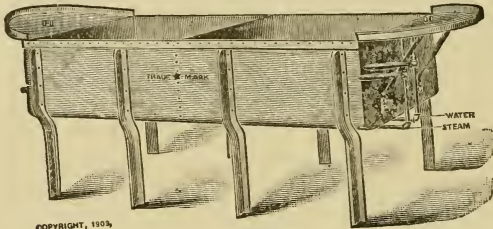

Wash Sink.

fishy taste to milk. A fishy flavor is said to be given to milk and butter when washing powder is not well rinsed from dairy utensils, also by cows drinking stagnant water.

Square cans have been recommended on account of the convenience and economy in stowing them during transportation in wagons and cars. The wooden stopper, which is used for milk cans in some places, is undesirable, as it is much more difficult to sterilize than the tin stopper. When milk cans become much battered and dented they are also difficult to keep clean and should not be used in that condition.

A convenient arrangement, when steam is employed, is the wash sink (see Fig. 25), provided with draining trays at each end.

The can is placed upside down over the two nipples in the tray, one supplying a jet of water to rinse the can, and the other a jet of steam to sterilize or kill germs in it. Various forms of brushes are desirable for scrubbing the utensils (see Fig. 26). They should be boiled daily for ten minutes after use.

To keep milk cool in cans during shipment the refrigerator car is commonly employed. Where this is not possible, the writer recommends the use of a cylindrical, hollow can of tin, with open top and closed bottom, being suspended bottom down, well into the milk or cream, from the mouth of the shipping can, and filled with cracked ice. The milk can jacket, made of hair, felt and canvas,

Fig. 26.

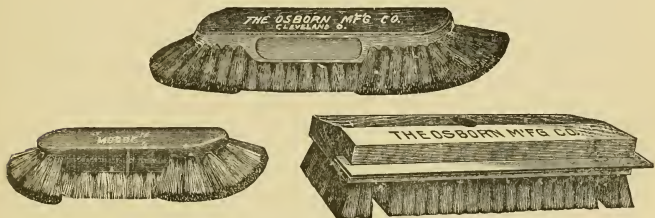

Various Forms of Brushes.

will protect cans against the effect of heat and cold to a considerable extent (see Fig. 27). Cans may be kept cool—while waiting for the train at a station—by placing a cake of ice on a stand raised three feet above the ground, and by stowing the cans about this and covering the whole with canvas reaching to the ground.

Bottled Milk.—If milk is to be shipped in bottles instead of cans, the following utensils will be essential in the milk room:

- Glass bottles, made to withstand heat, and delivery boxes.
- A receiving tank, with trap strainer.
- A cooler, with ice-water section.
- A collecting tank.
- A bottle-filler, with table.
- A sterilizer.
- A washing outfit.

The cooling arrangement is precisely as described above for cooling milk to be shipped in cans. When there are eight or ten milkers, so that the milk from as many cows may be mixed as soon as milked without loss of valuable time when it should be cooling, then the warm, mixed milk may properly be drawn directly into the bottles from the bottle filler. The bottles should, on being filled, be instantly immersed to the neck in ice water. In this way bottled milk may be suitably cooled, with the avoidance of the unnecessary exposure to two tanks and the air in passing over the cooler. The bottle filler is indispensable (see Fig. 28) for conveniently filling several bottles at once. By moving a lever one can fill from four to

Fig. 27.



Milk Can Jacket.

eighteen bottles to the same level at one time. The prices of these contrivances vary greatly with the size and material used in their construction.

The sterilizer is an important utensil. It is a tight chamber into which steam is turned, with the object of destroying germs, and is made to hold the bottles and absolutely every other dairy utensil with which milk comes in contact.

The germs are not only those which may have inhabited the milk, but occasionally there may be germs of disease contaminating the returned bottle, owing to it having been in a house in which such disease existed.

There are two styles of steam sterilizers—those in which the steam is not under pressure, and those confining steam under pressure.

The latter type is more efficient, in that with steam under pressure it is possible to obtain a much higher temperature than when it is not. Steam, when not under pressure, will not exceed in temperature boiling water (212° F.). With a pressure of ten

Fig. 28.

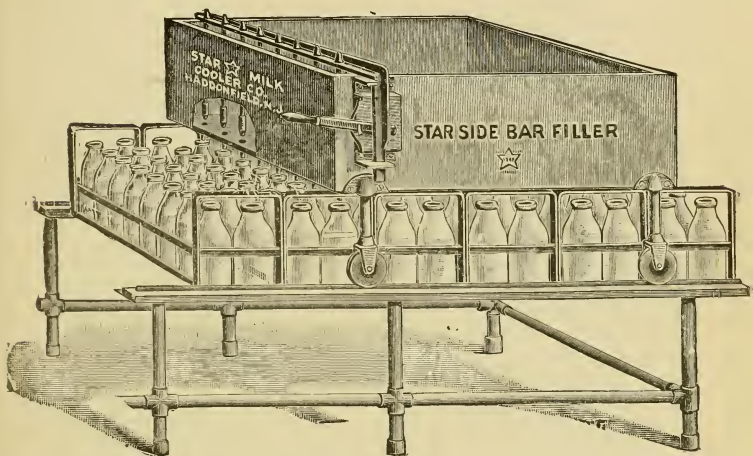

Star Side-Bar Filler.

pounds and a temperature of 241° F. in the high pressure sterilizers, it is possible to destroy the germs in the milk utensils with as much certainty in twenty minutes as with steam at 212° F. in the low pressure sterilizers in an hour. The heavy pressure or high pressure sterilizers are, however, exceedingly expensive, and, if the bottles are properly washed, there is practically no danger in relying upon the less expensive steam sterilizers in which the steam is not con-

fined under pressure. In Fig. 29 is shown a high pressure sterilizer. It must be built very strongly to withstand the pressure, which is over fifteen tons against the door alone, with a pressure of ten pounds of steam in the sterilizer. The matter of a sterilizer in

Fig. 29.

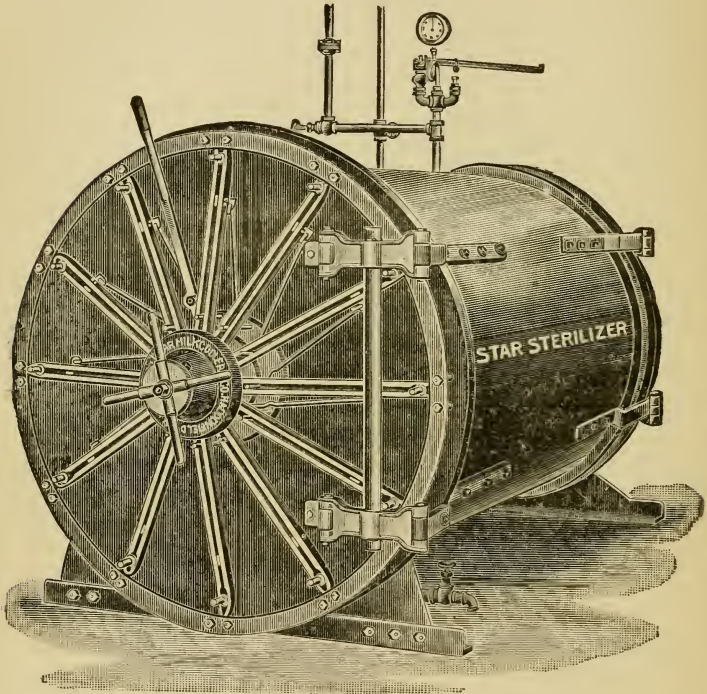

Star High Pressure Sterilizer.

which the steam is not confined under pressure is a comparatively simple affair. One may be home-made. The writer had a sterilizer built of two-inch plank, lined with galvanized iron, with double doors fastened with an iron bar across the front. The shape was

nearly square and the capacity was about 250 quart bottles. There was a movable sheet of galvanized iron, partitioning the sterilizer in two, and movable shelves of the same, perforated with holes, in which the bottles rested upside down on their shoulders. The shelves stretched horizontally across the sterilizer, from each side to the partition in the centre, resting on galvanized angle irons soldered along both sides and on each side of the partition in the centre. The shelves were just far enough apart to give room for a tier of bottles. Shelves and partition were removed to allow of room for sterilizing the milk pails, cooler, bottle filler and strainer, cheesecloths, and tanks supplying and receiving milk from cooler, etc. The sterilizer was fed from a ten horse power boiler with steam from below, and also had an exit or exhaust in the bottom, while at the top there was a hole in which was a cork holding a thermometer in place, with bulb inside and recording part outside of sterilizer. The doors were not steam-tight, and no pressure of steam was attempted or possible in the sterilizer, but the temperature was raised 212° in about twenty minutes, and maintained for the time—one hour—occupied by sterilization.

A very successful sterilizer has recently been made by my friend, Hon. W. H. Paulhamus, of Sumner, Wash., entirely of concrete faced with cement, and costing about \$75.00. It is a rectangular chamber $6\frac{1}{2}$ feet high by 8 feet wide and about 14 feet long and 6 inches thick, with one iron door. In the top, iron bars were used to reinforce the concrete. Two half-inch pipes enter one side of the chamber just above the floor for intake of steam from a twenty-five horse power boiler, and, at the top, there is a single pipe for outlet of steam when sterilization is over to cool off the oven, and one to drain the floor. In the middle of one side there is also a pipe inserted, large enough to hold a thermometer. This sterilizer will hold 100 dozen bottles and every bit of dairy apparatus used on four farms, including the milk pails and milk cans, coolers, and bottle filling apparatus, strainer cloths, etc. If one

does not wish to make a sterilizer, the largest size only should be bought (Fig. 30), as it is most economical in saving the expense of doing several sterilizations daily, because with it all bottles and every article of dairy utensil can be sterilized at one time. In case the Star galvanized sterilizer is used, the bottle carriers described on page 137 may be employed to hold the bottles in the sterilizer, or a rack and truck similar to that pictured on pages 103 and 104 may be utilized.

Fig. 30.

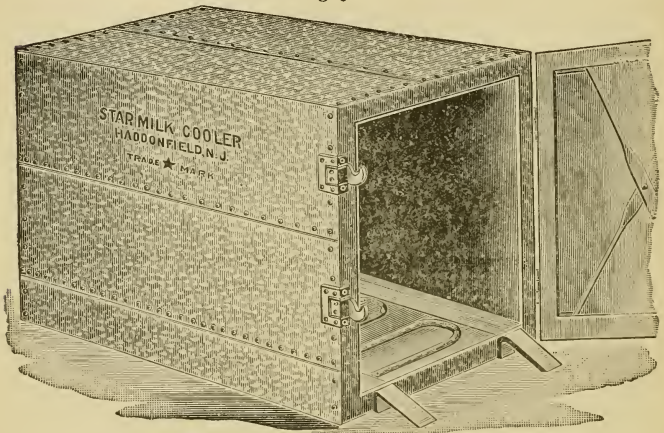

Star Sterilizer.

This sterilizer is made of heavy galvanized iron, riveted and soldered together, and holding from 240 to 632 quart bottles, according to the size. It is supplied with perforated steam coil and trapped drain outlet, and it is well to have an exhaust to carry off surplus steam, although the doors are not steam-tight when closed. A thermometer placed in the centre of the door is also advisable. Both the heavy pressure and the galvanized iron sterilizers are made either with a door at one end or a door at each end. The latter arrangement is a convenience when there is a separate room

for washing the bottles, the sterilizer being placed in the partition between the washing and bottling room and the bottles passed in the sterilizer through a door in the wash room and taken out through the other door in the sterilizer in the bottling room. Every single utensil with which milk comes in contact, including the various tanks and strainer cloths, should be thoroughly washed

Fig. 31.



Bottle Brush.

and sterilized after each milking for one hour at 212° F. To avoid sterilization twice daily, however, it is better to have two sets of utensils, which may be sterilized all together once daily.

Washing Outfit.—A separate room should be provided for washing milk utensils where the best plan is pursued. Since we are considering the essentials for handling clean milk we have not included a wash room separate from the milk room, as clean milk

Fig. 32.

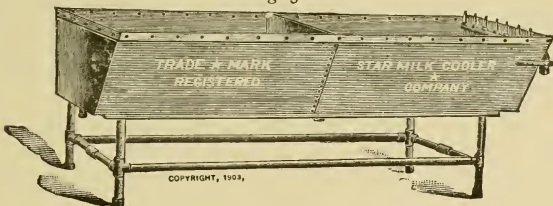

Star Metal Wash Sink.

can be handled in a combination bottling and wash room, although not to the best advantage. The bottles should be rinsed in warm water and washed with washing soda and hot water (in 3 per cent. solution) with a bottle brush (see Fig. 31), and then rinsed in clean hot water and inverted over the trays or shelves, which are placed in the sterilizer. The most convenient arrangement is such as that shown in the cut (Fig. 32), two tanks, one holding lukewarm water

in which the bottles are soaked, and the other hot water containing washing soda, while at the end there are projecting nipples over which the bottles are inverted, and, by turning the lever, several bottles are rinsed at once. Each tank has an overflow standpipe to carry off the grease floating on the top of the water.

An additional improvement is the turbine bottle washer shown in the illustration (Fig. 33). It consists of a revolving brush which is turned by a turbine wheel with steam at a pressure of twelve to fifteen pounds. In this cut are shown the two large tanks on the

Fig. 33.

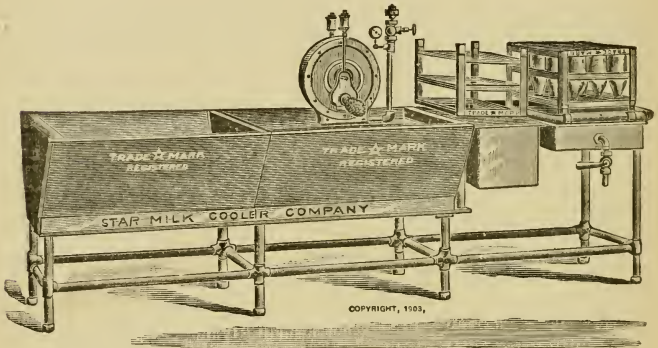

Star Bottle Washing Outfit.

left, for soaking and washing bottles in washing soda and water, and then the small tank, next the bottle washer, over which the bottles are inverted to be rinsed inside. This is accomplished by nipples, as shown in the cut (Fig. 32), spraying water into the interior of a number of bottles at one time, which are then dipped in the small tank below to wash the outside of the bottle, and are transferred to the tank at the extreme right to drain.

None of this special bottle-washing outfit is essential. Any convenient arrangement of tubs and hot water by which the bottles are put through three processes in washing—first rinsing in warm

water, then in hot alkali and water, and finally in clean hot water—will suffice.

If the bottles are thoroughly rinsed at the consumer's house the first rinsing in plain water may even be dispensed with, provided the bottles are thoroughly scrubbed inside with a brush and hot alkali water and well rinsed in clean hot water. The hot water may be supplied from a hot water tank, as suggested (p. 120), or by means of a steam heating tee (Fig. 34).

Fig. 34.

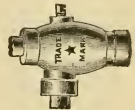

Steam Heating Tee.

This is an arrangement by which water may be heated to almost any temperature desired (short of boiling), by steam and cold water coming in contact, in varying proportions, according to the amount of either which is permitted to flow into the tee. Thus the steam enters the side and the water the top of the tee, both being regulated by valves in the steam and water pipes, and the hot water flows out below. Cold water or steam may be obtained separately also, from the device, which is comparatively inexpensive. A very convenient bottle-washing machine is shown in the Appendix (p. 328).

The routine of operating the dairy would be as follows: The empty, returned bottles would be taken from the wagon boxes into the milk room and there rinsed in warm water, in one tub, and then scrubbed with a brush in another tub holding alkali and water, as hot as the hand can bear. The bottles should be next rinsed in clean, hot water, inverted in the racks and placed in the sterilizer, where they are sterilized at 212° F. (as shown by a reliable thermometer) (Fig. 35) for an hour. The bottles should remain inverted until used.

The milk is brought from the barn in milk pails or cans, as soon as milked, and poured into the Star trap strainer resting in the receiving tank of the Star milk cooler with ice water section, or, better, into the covered cooler described on p. 119). The milk flows from the collecting tank of the cooler into a large can, if

it is desired to thoroughly mix the milk of many cows before it is bottled. Instead of a can for mixing the cooled milk, it is better to use the large tank for filling the bottles—that is, the bottle-filler tank; and after twenty gallons or more of milk have flowed from the collecting-tank of the cooler into the bottle-filler tank, the milk should be well stirred with a sterilized stirrer and the bottles filled while the milk is being mixed. The stirrer may be made like a huge fork, from heavy tin.

The warm milk of several cows may be mixed in the barn by pouring the contents of a number of milk pails into a large can. But unless there are enough milkers to do this within a few minutes, it is better to carry each milk pail to the cooler, as soon as it is full and mix the milk after it has cooled. The time elapsing between milking and bottling should be as short as possible. The

Fig. 35.



milk must be cooled instantly after milking, and be bottled within an hour of milking. In some establishments the milk is bottled within eight minutes of milking. The cooled, mixed milk is poured into the bottle filler and flows immediately into the bottles, which are then quickly capped with sterilized paper caps, and placed in the wagon boxes well surrounded with ice in warm weather. Milk bottles should always be cool before they are filled with milk. This is especially true of the smaller sizes, which it is wise to keep in cold storage an hour before filling. The milk should be delivered to the consumer the year round at a temperature not over 45° F. If not shipped immediately—as in case of the night's milk—the milk may be stored in the wagon boxes over night with ice or kept in cold storage or in sufficiently cold water. (Fig. 36).

All the dairy utensils should be rinsed in clean warm or cold water as soon as the milk has been bottled and then washed with

scalding alkali water and rinsed with clean cold water, and sterilized an hour in the sterilizer, including the cheesecloth used in straining the milk in the milk pails and in the Star trap strainer. It is safer to use new, fresh, sterile cheesecloth at each milking. The floor must be kept damp to avoid dust, and the windows and doors should be closed while the milk is being handled for the same reason. When dairy utensils are not in use, they may be kept in a sterilizer, or, if this is not practicable, it is well in many milk rooms to cover them with a clean sheet, to keep off the dust, and to rinse the cooler with clean, cold water just before using, for the same reason; or, better, to use a covered cooler. A properly con-

Fig. 36.



Machine for chopping ice used to pack about milk bottles.

structed and managed milk room should be dust-proof and dust-free, and such precautions should be entirely unnecessary.

Turning live steam against the walls of the milk room each day is useful as an aid to cleanliness, provided that they are constructed to withstand the process.

The employees in the milk room ought to wear clean, washable caps and clothes. Linen gowns, like those worn by butchers, which may be slipped over the clothes, are most convenient.

The final test of perfection of cleanliness of the milk, produced as described, is the laboratory. Such tests should be made

once a week. If the milk is sold as "certified," it must receive the sanction of some medical milk commission or Board of Health. The bacterial content or number of germs should not exceed 30,000. 10,000 germs is the maximum number permitted by many milk commissions (see p. 25) to the cubic centimeter, and this

Fig. 37.



Banjo Conductor for carrying milk through a wall.

is the proper standard according to the consensus of authorities at the present time, in so-called certified milk. It is perfectly possible to produce milk which shall not exceed in number 2,000 to 4,000 germs to the cubic centimeter by the comparatively simple and inexpensive plant which has just been described above, as the author has practically demonstrated.

Fig. 38.

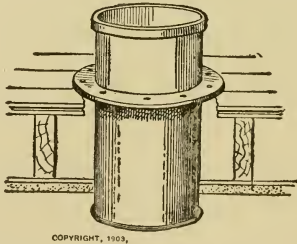

Cylinder for conveying milk through a floor.

A more perfect arrangement in a dairy building for handling clean milk is of advantage when one can afford it. The most important improvement consists in separating the bottling or milk room proper from the wash room, in which the sterilization and washing of the milk utensils are done, and to devote two rooms to these different processes. (1) The boiler and engine should have a

separate room, and adjoining this (2) a room for washing and sterilization, and then a room (3) in which the milk is cooled and bottled. A still further development comprises the following in the dairy building:

A Milk Receiving Room.
 A Milk Room.
 A Bottle Room.
 A Wash Room.
 An Engine Room.

A Boiler Room.
 A Cold Storage Room.
 A Shipping Room.
 A Lavatory.
 A Laundry.

Fig. 39.

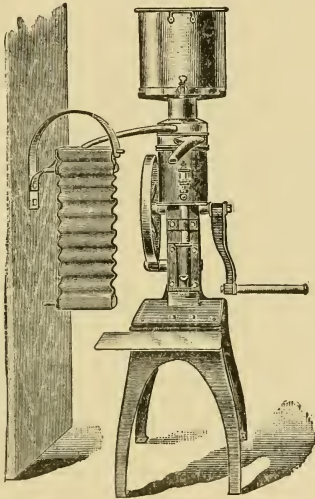

Cream Cooler connected with Separator.

The milk receiving room may be connected with the barn by a cable system by which two 5 to 10 gallon cans are suspended on can carriages running on an overhead wire. The milk receiving room is on a higher level than the milk room, so that the milk flows from it through the floor through a funnel or cylinder, or through the wall by a Banjo conductor (see Figs. 37 and 38) di-

rectly into the receiving tanks of the cooler or separator in the milk room below, thus avoiding unnecessary handling.

The milk room should not be connected with the outer air by a door or open window, but must be ventilated so as to exclude dust and only be connected with the other rooms. It contains the appliances for cooling and bottling milk we have already noticed, and also a separator, cream cooler and cream bottle filler (Figs. 39 and 40), if cream is to be made.

The bottle room adjoins the milk room, in which the clean bottles are kept after being sterilized. One end of the sterilizer

Fig. 40.

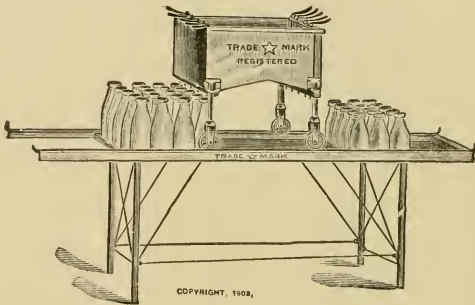

COPYRIGHT, 1908,
Cream Bottle Filler.

projects into this room from the wash room. The wash room contains the sterilizer, the bottle washing outfit, and a Babcock tester. The cold storage room is of great convenience where large quantities of milk are handled and may be arranged with natural ice, or by means of ammonia compression and an artificial refrigerating and ice-making plant. The lavatory and laundry are for the use of the employees in the dairy, the former with a shower bath, set basin and dressing room, and the latter to wash the clothes used by the employees. In the shipping room are the cases for holding the bottles, and the floor platform for loading the wagons should be on a level with them. Where there is machinery, as for a re-

frigerating plant, it is well to separate the boiler by a partition from the engine and fire room and thus avoid the dust, ashes and dirt from fuel.*

Space does not permit of more than a brief outline of the more elaborate dairy plant, but we would refer to one† who makes a business of planning and installing such, from whom we have derived many valuable suggestions. The object of this book is to detail the less elaborate and more essential methods which may be used by the farmer without great expense in the production of clean milk on a moderate scale.

Fig. 41.

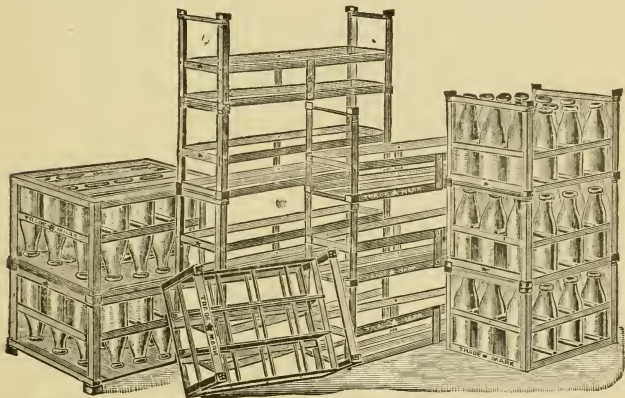

COPYRIGHT, 1909,

Bottle Carriers.

In the handling of milk bottles in the dairy, it is much more convenient—though not essential—if they can be transported and inverted in numbers without handling each bottle separately. Thus carriers have been invented for holding them, with reversing racks, so that the bottles may be inverted—as when they are washed and sterilized—by turning over as many as 20 bottles at once (see Fig. 41). Cars are also made which are used to transport these carriers

* For plan of milk house, see p. 324-36.

† Samuel M. Heulings, Haddonfield, N. J.

and the cars, carriers and bottles are all wheeled directly into the sterilizer and out again without handling the individual bottles (see Figs. 41 and 42).

Shipping Cases and Boxes.—Milk bottles of glass must be shipped in some sort of box. The writer has had such boxes made of strong galvanized iron (24 gage) with rolled edges at all the joints, with a hinged cover and padlock, and with metal handles at either end. Padlocks must be made to have the same key fit them all; but we have found great trouble in getting padlocks which

Fig. 42.

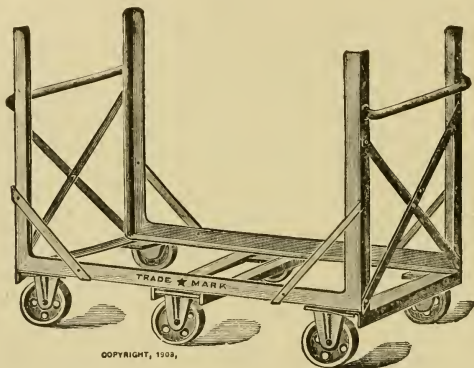

A Car for conveying carriers and bottles.

were not continually getting out of order. For this reason, and because keys for such padlocks are readily obtained by outsiders, I recommend the use of a lead seal having an opening through which the ends of short wires are passed. The seal is then compressed by a special punch, thus locking the ends of the wires and serving as a perfect padlock which is not likely to be tampered with without detection. The seal and wire for each shipping box cost about one-sixth of a cent and may be obtained complete with the punch. One called "The Enterprize Punch & Seal"

has proved efficient. The boxes hold 12 quart bottles, which are separated by a framework of galvanized iron on the same plan as the pasteboard partitions or fillers in egg cases. These frames lift

Fig. 43.

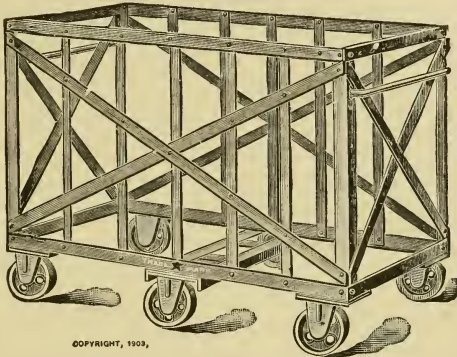

COPYRIGHT, 1903,

A Car for conveying carriers and bottles.

out of the boxes and are $3\frac{1}{2}$ inches deep. The boxes are $12\frac{1}{2} \times 17\frac{1}{2} \times 10$ inches deep and have a small hole punched in the bottom to allow the water, from melting ice, to drain away. This is advisable in saving ice and the weight of the water in

Fig. 44.

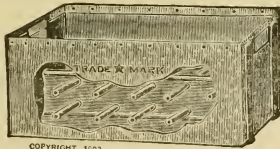

COPYRIGHT, 1903,

Wagon Box for carrying bottles and ice, not covered or locked.

transportation. I have found the locked boxes necessary to prevent theft of the milk and empty bottles in transportation. Boxes may be bought holding various quantities of bottles, as 20 or 14 pints (see Fig. 44). (For Bottle caps, see p. 168.)

Bottles.—In regard to glass bottles there is not much to say except that a bottle of good material and proper annealing must be secured to stand the repeated sterilizations (Fig. 45). The shapes are more a matter of taste than anything else. The bottles with the long and slender necks make a greater display of cream. The latest departure in the way of a milk bottle is the single service milk container of wood-paper made and invented by G. W. Maxwell of 2101 Folsom St., San Francisco. It is now in actual use by dairymen in Los Angeles, Cal. The containers in shape resemble an ordinary drinking glass. There are quart, $\frac{1}{4}$, $\frac{1}{2}$ and

Fig. 45.



Milk Bottles.

pint, sizes. The pints are $5\frac{1}{2}$ in. high and 3 in. across the top. The quarts are $6\frac{1}{2}$ in. high. The pints weigh 1 ounce; the quart sizes, 2 ounces. After the containers are filled with milk the paper cover is pressed down firmly into the narrowing container, until it becomes securely wedged in place, and is held there by four small tongues punched from the walls of the container (which press upon the top of the paper cover and are $\frac{1}{4}$ in. from the top rim of the container) by the bottle filling and capping machine (Fig. 46). After the containers are made they are dipped into melted paraffin at 220° F., which ensures absolute sterility and water-tightness. The containers and covers are nested and packed in sterile paper in

Fig. 46.

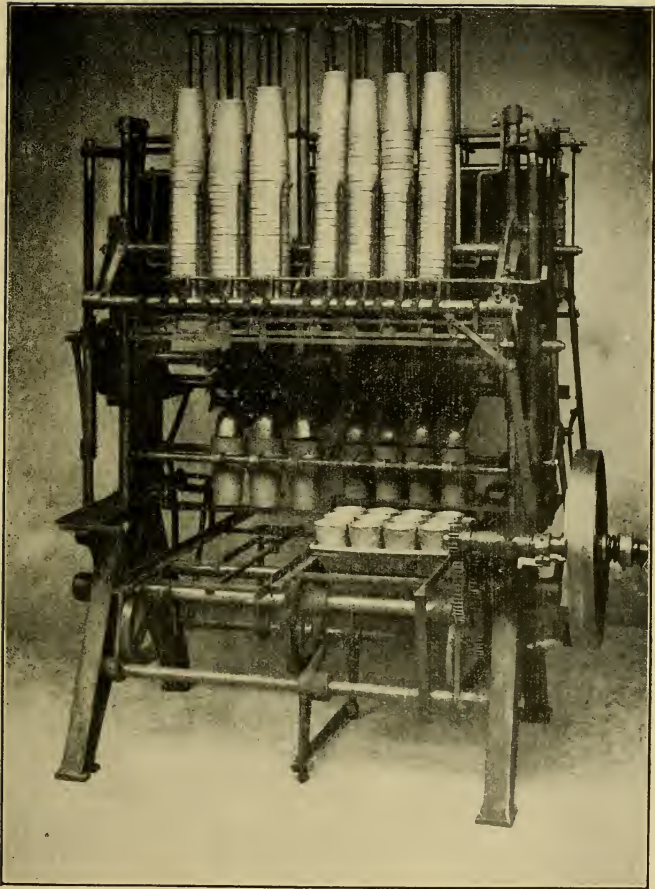

Maxwell Paper Bottle Filling and Capping Machine.

wooden boxes and in no part of the making or handling do either come in contact with the hands or other contaminating objects. Additional caps (to take the place of parchment paper caps on glass bottles) are supplied for certified milk to keep the dust from the inside covers of the bottles. An ingenious metal opener is provided consumers wherewith the covers are removed without danger of their falling sidewise into the container. A special machine (some of which are very cheap) is made for filling and capping the bottles so that the containers and covers are not touched by the hands. The paper bottles are several inches shorter than the glass bottles, on account of their thinner walls; the paper lids fit down into the bottle and allow of no leaking; and the necks are wide enough to remove the cream with a spoon. The cost is about 0.7 of a cent each for a quart, and 0.5 of a cent for pint paper containers. The paper container is first of all of most value because it is absolutely free from germs, *i. e.*, sterile. Then it does away with breakage, and with loss of glass bottles from various causes. Again, the paper bottle does away with the cleaning and sterilization required by glass bottles. And, moreover, there is saving in weight in transportation of paper bottles. The latter weigh 2 ounces against the 26 ounce glass quart bottle. A city dealer selling 3,000 qts. of bottled milk daily might save some \$60.00 monthly in loss of glass bottles, and as much more required for labor and power, by the use of paper bottles. But the paper bottles would cost some \$612.00 per month.

And, while there is so much saving in weight that almost twice as much milk could be carried on wagons in paper bottles, yet this is of little advantage, as it is now possible to carry as many glass bottles on a wagon as one man can distribute (300) in a day. There would be some saving of the milkman's time because he would not collect empty bottles. The only disadvantage which occurs to the writer is the fact that quality and quantity of the cream would not be so apparent in the paper bottles, nor would dirt.

The consumer is benefited in the great safety of the sterile containers in place of the often dirty milk bottle which may have just been used by a patient suffering from some contagious disease.

From a sanitary point of view the single-service, sterile, paper milk container is immeasurably superior to the (commonly) imperfectly clean glass bottle, and, from this point of view, its extra expense should not be considered. The advent of the paper container, while entailing some extra expense to the city bottler of milk, should be of enormous advantage in enabling farmers to ship milk in bottles at lower freight rates (on account of less weight and bulk of paper containers) and without all the expense of machinery and labor now required in washing and sterilizing glass bottles.

The same care should be exercised in the production of cream as in the case of milk. While 99 per cent. of germs in milk are to be found in the cream which rises naturally on that milk, separated cream contains about one-fourth of the germs in the milk from which it is obtained. But as the cream constitutes only a small part of the original milk—say one-sixth—the actual number of germs in a given amount of separation-cream would be greater than in the same quantity of the milk from which the cream was separated.

Cream in cities is consumed largely on the table and for making ice cream and whipped cream. Fatal poisoning has occurred from ice cream made from unclean milk (see p. 38). Babies are chiefly fed nowadays on cream and water. The cream is usually removed from milk at the infant's home, but market cream is often used for this purpose.*

When cream is used for any of the purposes recited, it is imperative that the cream should be clean or as free from germs as possible. We have already alluded to the value of clean cream for butter-making.

The warm milk direct from the cow must be immediately

* The composition of proteids is altered by separation of cream by centrifugal action. Thus albumoses and peptones from averaging 9.69% of proteids in fresh milk are increased to 18 to 38% in separator cream. Gravity cream is thought better for infant feeding.

separated, as a temperature of 86° F. is most favorable for separation. Nor must time be permitted for germs to multiply in the warm milk between milking and separation; the milk must be separated as fast as milked. As soon as the cream is separated it should be immediately cooled to below 50° F., preferably to 40° F. This is best accomplished by allowing the cream to run

Fig. 47.

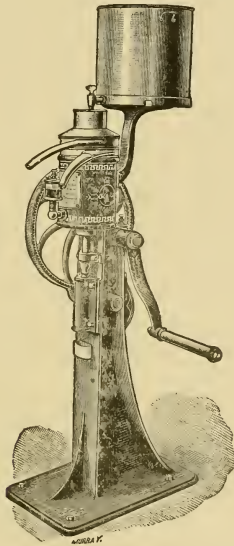

Hand Separator for separating cream from milk.

directly from the separator into the receiving tank of a tubular or Star cooler. The cooler is identical with that for milk, but the holes are larger in the receptacle which feeds the cooler. The cream is transferred from the collecting tank of the cooler to a cream bottle-filler, and then is run into sterilized bottles. The bottles are shipped like milk in shipping boxes and, except in cold weather, are packed in ice. The bowl and all movable parts of the

separator must be washed as carefully as any other dairy utensils by first rinsing in cold water, then scrubbing in warm water and washing soda with a brush, and rinsing again with clean, cold water. Finally, the parts should be sterilized with boiling water or by placing them in a sterilizer. All this should be done after each use of the separator. For this reason a separator having as simple construction and as few parts which come in contact with milk as possible should be preferred. The Sharples separator is one of the simplest in this respect and therefore most readily cleaned.*

If the cream is shipped in cans, it may be kept cool in the same manner as that recommended for milk (see p. 123). Cream thickeners of gelatin are not uncommonly used to thicken cream. Starch and syrup of lime, known as "Viscogen," are also employed. Separated cream does not whip quite so readily as set cream, and syrup of lime may be used to aid its whipping, without injury to the consumer, provided that only a small amount—not over one-half teaspoonful of the syrup to the pint of cream—is used. In fact, this proportion is often employed in cream mixtures for feeding babies to increase the digestibility of the cream. Viscogen should not be added to cream for sale in the market. For tests for adulterants of cream, see p. 192.

Cream of varying composition is sold in the market. It generally varies from 20 to 50 per cent. in fat-content. Cream must contain at least 18 per cent. of fat according to the U. S. Pure Food Law, June, 1906.

In order that cream may be readily whipped, it should contain over 20 per cent. of fat and be below 50° F. in temperature. Cream containing 23 per cent. fat is most economical for whipping, as an excess of fat does not aid the process. Cream should be at least 24 hours old—to contain a small amount of acid—in order to whip well, and for ice cream. Pasteurized cream will not whip

* See page 321 for management of separators.

satisfactorily unless viscogen is added to it; or a starter, to develop slight acidity in it. The vessel in which the whipping is done should be cold and round-bottomed; the whipping should be done with great speed; and the whipper should not be more than three-fourths covered with cream. The cream sold in this city (Seattle) commonly contains from 31 to 33 per cent. of fat.

In concluding the subject of the production and handling of clean milk and cream, I wish to emphasize the fact that most farmers can produce clean milk without great expense in ordinary barns and milk rooms, and can, by so doing, make more money—even with the added expense.

If paper bottles come into general use, the greater part of all the extra trouble and expense now entailed in bottling milk at the farm will be abolished. Clean milk may be shipped in cans, with but slight cost over ordinary milk, and is just as satisfactory, providing the cans go directly to the consumer and their contents are used wholly by him. It is the constant dipping into cans in retailing small amounts of milk which causes the contamination, as noted on p. 27.

CHAPTER VII

COST OF PRODUCING AND DISTRIBUTING CLEAN MILK

A FEW words first in regard to the cost of production and profits on ordinary milk sold to creameries, for butter and other products; and for consumption as market milk in cities and towns throughout the United States.

It has become only too evident to readers of dairy literature of late that a large number, perhaps the majority, of milch cows in this country do not yield any considerable profit to their owners.

In the Cow Census made by Hoard's Dairyman in Vermont (see the number for August 1st, 1905), it was shown that out of 100 dairies, 69 did not pay the cost of keeping the cows. The cows were natives or grades.

The estimated cost of feeding ranged from \$33.50 to \$41.00 per cow, per year. The annual profit per cow, of the 31 dairies which paid any profit, varied from 43 cents to \$22.57. The losses per cow annually, in the dairies which did not pay, ran from 2 cents to \$21.46. The production of the dairies varied from 72 to 270 lbs. of butter fat per cow annually.

Again, in a report of the Ohio Cow Census in Hoard's Dairyman of April 28, 1905, we find that among 87 herds representing 635 cows, with a yearly average of 3,839 lbs. of milk per cow, the average yearly return was \$29.93 per cow. Among this number of 87 herds, 29 herds were kept at a loss, and out of the whole 87, only 26 herds paid a yearly profit of over \$5 per cow to the owners.

Yet in the Ohio report we note one herd of 24 cows, mixed breeds, yielding annually per cow an average of 7,756 lbs. of milk and giving a yearly profit of \$167 per cow. Again, in this same report, we discover another herd which paid its owner an annual average profit of 10 cents per cow. How may we explain such an enormous inequality in returns? Let us compare the report of the two herds:

	Herd No. 12 (2 Jerseys, 3 grades)	Herd No. 100 (Mixed Breeds)
Cost of keep per cow yearly	\$25.00	\$70.00
No. lbs. milk per cow yearly	3,048	7,756
Profit annually per cow	\$0.10	\$167.00
Returns from \$1.00 invested in feed	\$1.00	\$3.40
Average price of milk per 100 lbs..	\$0.62	\$3.05

In herd No. 12, we find that the annual cost of keep was \$25, and the yield 3,048 lbs. of milk, which brought 82 cents per 100 lbs. at the creamery, or a little less than 7 cents a gallon the year round. A gallon of milk weighs 8.6 lbs. Herd No. 100 paid yearly \$167 per cow, while the cost of keep was \$70 per cow, and the milk brought a little over 25 cents a gallon, or over 6 cents a quart the year round.

Certain remedies there are for such a disparity in profits, but, under some conditions, this disparity can only be remedied in part.

In the cases in point, the most essential cause of the difference in profits in the two herds is the difference in price, which depends upon circumstances. The owner of herd No. 100 was near enough to the city of Cleveland to retail his milk for over 6 cents a quart, whereas the product of herd No. 12 was sold for less than 2 cents to a creamery.

In this comparison, there are, however, other points to consider: the fact that the cows in herd No. 100 gave over twice the quantity of milk yielded by the cows in herd No. 12 is an important matter. This may have partly depended upon the care of the cows and feeding, but was very probably chiefly due to the character of

the cows themselves. While it would be impossible for any one to make much profit in milk at less than 2 cents a quart, yet it may be accepted that, unless a cow comes up to a certain standard in regard to quantity and quality of milk, it is unprofitable to keep her, and the sooner that cow and her owner are parted the better. Just what that standard should be will depend somewhat on local conditions, and prices of food, and milk; but, in a general way, the cow that will not average about 10 quarts daily during 10 months of the year (6,000 lbs. annually), and whose milk falls much below 4 per cent. fat, on the average (unless the quantity is very large), will not pay to keep. In this region, there are many herds of grade Holsteins, containing as many as 80 to 120 heads, which average 16 quarts and over per cow during the summer months—on pasture alone—in the rich valley lands. In order to determine whether individual cows are profitable, the farmer must weigh the daily amount and test the butter fat of each cow's (see p. 322) milk at frequent intervals. Each cow's milk should be weighed separately, directly the cow is milked, by hanging the milk pail on a balance scale (the Chatillon balance, costing about \$3.00 at any dairy supply house, is the best) and recording the weight on a record sheet which is gotten up for this purpose (see Appendix, p. 322.) The record sheet should be kept near the weighing balance in a room devoted to this purpose in the barn. To determine the percentage of fat in the milk, a composite sample—that is, a sample of a mixture of the same quantity of night's and morning's milk of each cow for three days—should be examined by the Babcock test at the beginning and end of each month. The composite sample is obtained by pouring the fresh milk from one pail to another, and from the mixed milk one should remove a gill with a long-handled dipper at each milking. The gill is placed in a clean labelled and covered Mason glass jar, which is shaken each time a new sample is added. Fifteen drops of formalin or half a powdered B. & W. corrosive sublimate tablet will preserve the samples for days, and

two ounces, or half a cup of the composite sample, is sufficient for the Babcock test. If a Babcock tester is not at hand, the testing may be done at a creamery for a small charge. The number of pounds of milk yielded by each cow monthly should be multiplied by the average per cent. of fat in her milk. This will give the number of pounds of fat in the cow's milk for the month, which should be the basis for comparing her value. The average per cent. of fat in her milk for the month will be obtained by adding together the results of the two fat tests and dividing the sum by two. Then the general care and feeding governs to a considerable degree the quantity of milk, and intelligent study of a good newspaper devoted to the dairy industry will prove of much value in this respect. As we have repeatedly emphasized, the cleaner the milk the better it is for any purpose, and the farmer who devotes himself to producing a clean milk should receive a larger price for it. Of course, local conditions will largely determine the advisability of investing extra money and time in the food, care and cost of cows, but very rarely will it *pay* to keep cows which do not *pay* for their keep. It may be necessary to keep cows for their manure, but this is usually considered as merely offsetting the cost of their care, and so the cost of keeping cows is commonly figured in estimating the cost of their food. The yearly cost of feeding a cow varies from \$17 to \$90, averaging perhaps throughout the United States about \$35. At the experiment stations, with the best selected stock and breeds and the most expert care, the cost of producing 1 quart of milk varies from 0.7 to 2.9 cents, according to breed and individual characteristics of cows. When a farmer receives on the average 2 cents or less per quart for milk, there can be little profit to him. Yet two cents was about the price paid for years to farmers who have shipped ordinary market milk to New York City.

It has been stated by many authorities that one-third of the cows in this country is kept at a loss; that one-third just about pays for its keep, and that one-third pays a profit to their owners.

The most striking fact which impresses one in this whole matter of profit in milk production is the folly of keeping poor cows. A *poor* cow makes a *poor* owner.

The production and transportation of clean milk is attended with much greater expense than that of ordinary or "market" milk.

The following figures, showing the cost of milk production and distribution, must, of course, be considered only approximate. Local conditions alter circumstances tremendously. Thus in this region (Seattle, Wash.), the climate is so mild that ice has to be used on the milk during transportation on the railroad and delivery in the city wagon the year round. Then again, the city is very hilly and the streets, many of them, very bad, and the milk route is not concentrated in a thickly settled district.

We may place the average cost of the production throughout the country of ordinary market milk at 2 to 2½ cents per quart as the result of the figures obtained from the experiment stations in the past. Owing to the exceptional high cost of cow feed and labor in recent years, Dr. E. B. Voorhees, of the N. J. Exper. Sta., has lately (1907) computed that it costs the farmer from 4.7 to 6.55 cents per quart to raise milk. The range in the price of the cost quoted depends upon the cost of the investment and labor, the cleanliness of the milk produced, and also whether the farmer charges more than the cost of ordinary farm labor for his time. Perhaps the average figure hitherto paid the farmer for ordinary market milk hereabouts is 3½ cents a quart. This does not differ materially from the price paid in many parts of the country. At present (Feb., 1908) the farmer is receiving about 4¾ cents net for ordinary market-milk in this locality (Seattle, Wash.) which retails at 10 cents a quart for bottled milk.

The cost of producing clean milk in this region, over and above that of ordinary milk, may be set down at 2 cents a quart. This includes the extra care necessitated in the barn and dairy.

the fuel for running the boiler, the ice, etc. In the milk room, there is the washing and sterilizing of all the bottles and apparatus, and the bottling of milk and packing of the bottles in boxes with ice. The farmer must make a considerable outlay for the paraphernalia in his milk room, but the bottles, in this vicinity, are supplied by the distributors in the city.

The minimum price paid to the producer is about 6 cents a quart—the bottles, cases and freight being paid by the distributor. The highest price paid in any part of the country to the producer for bottled, certified milk delivered at the local R. R. station is at present 10 cents.

The cost of transporting milk by rail in bottles to the city, some 30 miles, is 1 cent a quart in this region, and it costs about the same in other cities. This figure includes the cost of carriage for the galvanized iron box, holding one dozen bottles and ice, the whole weighing 68 lbs., and also the return of empty bottles and cases to the farm.

The cost of distributing clean milk is much greater than ordinary milk, when ice is used, owing to the weight of the ice and cases holding the bottles and the fact that customers of high priced milk are apt to be scattered about. The cost of distribution of bottled milk has been set down at two cents a quart, but three cents a quart would be nearer the mark in this vicinity for milk sold on ice the year round. The farmer should then receive at least seven cents a quart net for bottled certified milk as the minimum figure, according to my experience in this region, or about double what he has received for ordinary market milk. This is a uniform price for the year around. For the ordinary milk he has hitherto received from nine cents to sixteen cents per gallon, at different seasons, and it has retailed at about seven cents a quart (bottled).

The distributor of milk, if he pays the farmer seven cents per quart for bottled certified milk on ice and one cent per quart freight, should get twelve cents as a minimum price per quart to

make any profit. This figure is a low estimate when various unavoidable losses are taken into account, as repairs and deterioration of milk boxes, harness, sickness and death of horses, loss of accounts, bottles, etc. I believe that seven to eight cents a quart for bottled milk, for the farmer, and twelve to fifteen cents a quart for the distributor of clean milk in the city, is a safe estimate as a basis on which a profitable business for both may be done.* The price of certified milk is on the average sold retail for 5 cents more a quart than ordinary market milk, the price of market milk varying with the locality. It is impossible to keep up the standard of clean milk unless a reasonable profit is being made at both ends of the business.

When milk is bottled and retailed in the city the cost is about as follows:

Freight and cartage	1½ cents.
Bottling and icing	1½ cents.
Wagon delivery	1 cent.
Office expenses per quart	¼ cent.
Total cost of handling	4¼ cts per qt.

If milk is delivered by wagon directly from farm to consumer, the freight, cartage, and office expenses are cut out and labor is often cheaper in country towns, so that the cost of handling and delivering milk direct from the farm to the consumer would be from 2 to 3 cents a quart.

Every step by which the milk is improved costs money in labor or material, and it has been my experience that it is useless to ex-

* In Hoard's Dairyman of a recent date the proportionate receipts from a quart of milk retailing for 8 cents in New York City, are given as follows:

	Cents
Producer receives.....	2.75
Railroad for transporting, receives	0.5
Dealers handling, bottling and distributing the same, receive	4.75
	8.00

pect the farmer to carry out all the necessary details of cleanliness unless he can really afford to do so. The actual price at which certified milk retails varies in various cities from eight to thirty cents per quart. Rich milk, as milk containing five per cent. fat, should bring a higher price, though it is not preferable for infant food—rather the reverse, as we have noted.

In this vicinity there has been an attempt to employ one farm as a bottling station in which the utensils of all the farms are washed and sterilized and to which milk, which has been milked and cooled at neighboring farms, is brought. When the milk was supplied by the farm doing the bottling, and one other about a mile away, the result was very good. The highest number of bacteria in the milk bottled from these two farms was 17,000 per cubic centimeter during six months. Pressure being brought to bear to increase the milk supply, several more farms were taken into the combination with disastrous results. This unfortunate outcome was largely due to the fact that the owners of the farms which were taken into the combination last had not time given them to arrange their barns and milk-rooms properly, and had not got into the routine necessary to produce clean milk. Whether an arrangement of this kind for producing certified milk is wholly practicable is somewhat doubtful. There are so many more opportunities for contamination of the milk with dirt and germs. If a like attempt is elsewhere undertaken, the milk from each farm should be examined once a week before bottling it and mixing it with milk from the other farms, to ascertain the number of bacteria and the amount of fat in the milk. The plan has the advantage of bringing several farmers to a higher standard than would otherwise be possible, and enables the farmer who supplies all the dairy apparatus to make a more economical use of his plant.

The central plant, at which all milk pails, strainers, cans and other milk utensils are washed and sterilized before each milking, may be a creamery. Farmers should deliver milk within an hour

after milking. In the instance just cited the farmers receive $4\frac{1}{2}$ to 5 cents for milk in cans, and the central plant 7 cents a quart for milk in bottles delivered at the nearest R. R. station. Such milk, if not up to certified standard, should be much superior to ordinary market milk—especially if obtained from tuberculin tested cows.

When an individual wishes to begin to sell clean milk in a neighborhood in which certified milk is unknown, it is well for him first to interest the local medical profession in the project. The local medical society, or individual physicians, should form a committee with laboratory facilities. The work can be done under the committee's direction by an intelligent druggist. Any dairy, supplying clean milk, may receive a certificate from the medical commission, if the milk fulfils the required standard, as the result of weekly laboratory examinations and inspections by a veterinarian at intervals of two weeks. Providing, however, that the milk has fulfilled all the requirements of the milk commission for a probationary period of at least two months prior to the granting of a certificate.

Estimation of the Value of Milk and Cream for Ordinary Purposes

The value of milk and cream throughout the country is generally determined by the price of butter. And the butter maker pays for milk or cream according to the pounds of butter fat each contains. Clean milk or cream of the purity of the certified milk or cream, however, bring a price greatly above that fixed by a butter-fat valuation.

In churning a pound of butter fat (in milk or cream) into butter there is a gain; that is, a pound of butter fat will produce more than a pound of butter. The weight of the butter fat subtracted from the weight of the butter (made from it) is the over-

run.* The reason for this gain in churning butter fat into butter is that there are ingredients in the milk or cream, and also the salt contributed by the butter maker, which add to the fat in the butter. Thus butter contains on the average about 84 per cent. of fat, and the remaining 16 per cent. consists of water (12 per cent.), and curd (1 per cent.), salts (2.5 per cent.), and milk sugar (0.5 per cent.). This is the average composition of butter,† but the water may vary in amount from 8 to 16 per cent. and the fat proportionately. The overrun, then, does not depend upon nor refer to the percentage of fat in butter. It is always estimated by determining the fat in the milk or cream by the Babcock test, and then subtracting the weight of the fat from the weight of the resulting butter.

The amount of butter which can be made from a given weight of cream depends upon the amount of fat it contains. The richer in fat it is, the less the loss of fat in the buttermilk in churning. Thus buttermilk contains about 0.3 per cent. of fat, and cream containing 15 per cent. of fat would yield almost four times as much buttermilk as cream containing 40 per cent. fat. Moreover, the buttermilk from rich cream contains absolutely less fat (less than 0.3 per cent. fat) than that derived from churning thin cream. Then there are mechanical losses of fat from cream and butter sticking to various utensils used in the course of making and handling butter. This naturally influences the amount of butter which can be made from a given quantity of fat in milk or cream. Two to five pounds of butter-fat may thus be wasted for every hundred pounds handled.

* For detailed information concerning overrun, see Bull. 129, *Some Creamery Problems*, E. H. Farrington, Univ. Wis. Agric. Exper. Sta., to which the author is greatly indebted.

† Since the U. S. Pure Food Act of 1906 requires that butter shall contain 82.5 per cent. of butter fat as a minimum, it follows that creamery butter will not in future exceed this requirement. This, therefore, may be regarded as the present average content of fat in butter.

The Overrun.—As an example we will estimate the overrun in making 116 pounds of butter from 2,500 pounds of 4 per cent. milk. We first determine the weight of fat in the milk: 2,500 pounds multiplied by .04 equals 100 pounds of fat. Subtracting this from 116 pounds of butter made from it gives us the overrun as 16 pounds, or 16 per cent., because it is 16 per cent. of the 100 pounds of fat in the milk.

The overrun is usually less on account of various losses. Thus in skimming the milk in the separator there is a loss of about 0.1 per cent. of fat contained in the skim milk; after churning there is the loss in the buttermilk we have noted equal to 0.3 per cent. fat in the buttermilk; and there are the mechanical losses we have referred to, equivalent to about 2 to 5 per cent. of the total fat in the milk. So of the 100 pounds of fat in the 2,500 pounds of 4 per cent. milk there may be only 93.13 pounds of fat available, which would make 110.86 pounds of butter containing 84 per cent. of fat. Subtracting from this 110.86 pounds of butter the 100 pounds of fat contained in the 2,500 pounds of milk gives 10.86 pounds, or 10.86 per cent., as the amount of the overrun. The overrun varies, not only owing to the conditions noted, but also as the churning leaves more or less water in the butter, and according to the accuracy of testing the milk or cream for fat, and in weighing the same. The normal range in overrun for milk varies from 10 to 15 per cent. An overrun above or below these figures demands an investigation. The overrun from cream is somewhat higher than these figures, since there is no loss from skimming, as from milk. The cream overrun varies from 16 to 20 per cent.

Estimation of the overrun is not in any way essential in calculating the money due patrons of a creamery for milk or cream. The simplest, fairest, and generally most satisfactory way is to weigh and test each sample of milk or cream of the patron's for butter-fat and subtracting the cost of making the butter from its selling price, to give the balance of the returns to the patrons in

proportion to the butterfat they supplied. Thus, if 232 pounds of butter were made during a given time from 200 pounds of butterfat, and the butter sold at 25 cents a pound, the butter fetched \$58.00. Subtracting from this 4 cents a pound for making gives \$48.72 to be divided among the patrons according to the amount of butter-fat each supplied. 48.72 divided by 200 gives us 24.35 cents as the price to be paid each patron for each pound of fat supplied in his milk or cream. The following correction should, however, be made:

The milk patron is paid for all the butterfat in his milk brought to the creamery while the cream patron is not, as part of the butterfat in his milk remains at the farm in the skim milk. Besides, he saves the creamery the expense of skimming the milk. Therefore, in calculating the amount of fat supplied the creamery by its patrons the cream patron should be credited not only with the fat actually present in his cream, but to it is added 3 per cent. of its total to put him on the same basis as the milk patron. (The 0.12 fat lost in the skim milk from hand separators equals about 3 per cent. of total fat in the whole milk.)

Thus, supposing four patrons supplied the 200 pounds of fat, as follows:

	Fat.	Corrected Weight of Fat.
Milk patron	32.5 lbs.	32.5 lbs.
“ “	45.5 lbs.	45.5 lbs.
Cream “	$62 \times .03 = 63.8$	63.8
“ “	$60 \times .03 = 61.8$	61.8
	<hr style="width: 10%; margin: 0 auto;"/> 200 lbs.	<hr style="width: 10%; margin: 0 auto;"/> 208.6 lbs.

We correct the weight of fat supplied by the cream patrons, as above, and divide the price the butterfat brought (\$48.70) by the corrected weight of the fat (203.6 lbs.), which gives 23.92 cents. This is the price per pound of butterfat to pay the patron of the creamery according to the corrected weights of fat in the last column above.

To consider this matter more in detail, especially in regard to the price a given quantity of milk will bring if sold in different forms, suppose we take, for example, 290 gallons of milk. A gallon of milk weighs 8.66 pounds, 290 gallons of milk will then weigh approximately 2,500 pounds, and, containing 4 per cent. of fat, will give us 100 pounds of fat. In converting this into butter the first process will be to skim the milk in a separator, which will give us a loss at the creamery of 0.1 per cent. fat in the skim milk. The skim milk may be assumed to be 85 per cent. of the whole milk; 85 per cent. of 2,500 pounds equals 2,125 pounds skim milk; 2,125 multiplied by 0.001 equals 2.12 pounds of fat in the skim milk. Subtracting this from the 100 pounds of fat in the 290 gallons of milk gives us 97.88 pounds of fat in the cream arising from this amount of milk; 326 pounds of 30 per cent. cream will contain just about this amount of fat, that is, 97.8 pounds. In churning this into butter there will be a loss of 0.3 per cent. of the total fat in the buttermilk. The amount of buttermilk is the difference between the weight of the cream and the fat in the cream, or, roughly, 10 per cent. of the whole milk. In 326 pounds of 30 per cent. cream there are 97.8 pounds of fat; subtracting this from the weight of the cream gives us the weight of the buttermilk, 228 pounds; multiplying this by 0.003 equals .684 pounds, or the loss of fat in buttermilk; subtracting this loss of fat in buttermilk from the fat in the 30 per cent. cream gives us 97.12 pounds of fat for butter. This would make 117 pounds of butter containing 83 per cent. of fat. (To arrive at this result we divide 97.12 by 0.83, equals 117.) Then, to get the (theoretical) overrun, we subtract the 100 pounds of fat in the original milk from the 100 pounds of butter made from it (117), which gives us 17 as the percentage of overrun. We will, however, have mechanical losses equal to 2 or 3 pounds, so we will consider that we shall actually get 114 pounds of butter from 290 gallons of 4 per cent. milk. The cost of making a pound of butter varies from four cents to a fraction

less than two cents in large and well conducted creameries. In calculating the amount of butter which can be made from a given amount of butterfat we add one-seventh to butterfat in milk and one-sixth to butterfat in cream. The butterfat in cream makes a larger amount of butter, because there is not the loss of fat in skim milk. With butter wholesale at 22 to 40 cents a pound, and subtracting 4 cents for making, the butter would net the farmer \$20.52 to \$45.60 for his 290 gallons of milk.

Cream is often bought in cities by ice cream and cream dealers at a rate of 2 cents (more or less) above the value of the cream for butter; that is, if butter was 22 cents the cream would be bought at a valuation of butter at 24 cents; 326 pounds of 30 per cent. cream equals about 40 gallons (a gallon of 30 per cent. cream weighs nearly 8 pounds actually; if free from much air or gas, 8.3 pounds) this, making 114 pounds of butter valued at 24 cents to 42, 2 cents above current butter price, would give \$27.36 to \$47.88 as the price for 290 gallons of milk in form of cream. In either case the farmer has the skim milk to feed, which may be roughly valued at 35 cents per 100 pounds for feeding, and 11 cents additional (in passing through the calves) for fertilizer; 2,125 pounds of skim milk at 46 cents per 100 pounds equals \$9.77; 290 gallons of ordinary market milk may bring the farmer 12 to 19 cents a gallon net if sold for city consumption, equals \$34.80 to \$55.10.

For clean, pure 30 per cent. cream, bottled at the farm, as much as \$1.20 to \$1.40 per gallon should be gotten. If the cream is shipped in cans on ice or in special ice-containing cans (see p. 123), it should bring \$1.00 to \$1.20 per gallon for a clean article. If the milk were sold in bottles from the farm as certified milk it should bring the farmer 7 cents a quart, delivered on ice at the nearest railroad station, at least, which amounts to \$81.20 for the 290 gallons.

The returns from 290 gallons of 4 per cent. milk, sold as follows, are:

As 114 pounds of butter, at 22 to 40 cents per lb. with value added of skim milk to farmer	\$30.29 to	\$55.30
As ordinary milk in cans at 12 to 19 cents per gallon..	34.80 "	55.10
As cream, with value of skim milk added	37.13 "	47.88
Clean, cooled cream shipped on ice in cans, with value of skim milk added.....	49.77 "	57.77
Clean, cooled bottled cream, with value of skim milk added	57.77 "	65.77
Certified bottled milk	81.20	

These figures, of course, cannot be taken as applying precisely to conditions in any given locality, or to any one time. A considerable range in the prices of butter, cream and milk will be observed in the foregoing table. As great fluctuations occur, however, owing to the season or locality, the higher prices represent those prevalent hereabouts at present (Seattle, Feb. 1908). Certified milk is sold at the same uniform price the year round, as it is not affected directly by the laws of supply and demand at the present time. The figures are only given to show how to calculate approximately relative returns from milk products, and it will be found that the returns for ordinary market milk are about the same as can be gotten from a creamery for butter. Moreover, the higher returns received from the sale of bottled certified milk must not be taken as necessarily indicating that the maximum profit accrues from selling milk in this form. It may well be that the extra cost of labor, fuel, ice and plant, required for its production, will amount to 2 or 3 cents a quart.

It is impossible to fix the value of skim milk for feeding and fertilizer, as it depends upon such variable factors as the value of veal and pork, the price of other food stuffs, the value of milk in the locality and the knowledge of the person using it as to the best way to feed it. Skim milk is said to be worth \$1.00 a hundredweight in midwinter to feed to hens with corn meal, while-

for feeding calves it is valued from 20 to 40 cents a hundred-weight, according as the price of veal varies from \$3 to \$5 per 100 pounds. To be fed with most economy to calves it should be given in proportion of two to three pounds of skim milk to every pound of meal. I have known skim milk to be used with excellent result when poured on the soil as a fertilizer in the cultivation of cauliflowers. H. B. Gurler claims that for feeding pigs skim milk is worth one-half as much per 100 pounds as corn is worth per bushel.

CHAPTER VIII

SOME HINTS CONCERNING MILK DISTRIBUTION

ONE of the chief difficulties to contend with in retailing milk is the almost instinctive desire of the public to get their milk in the early morning hours. Customers apparently labor under the false impression that milk left in the early morning hours is a product of the night, like the dew, or early morning paper on the doorstep. As a matter of fact, milk which is delivered before 8 A. M. at the customer's door is usually twenty-four to thirty-six hours old. This happens because milk trains do not often arrive before 8 A. M., and the milk on these trains represents that milked the night before and in the early morning of the day of arrival in the city. This milk is often delivered in the early morning of the day following that of its arrival in the city.

Although we have seen that clean milk may be kept sweet on ice for several weeks (see p. 22), yet we have also learned that germs will develop in milk at a temperature of 40 degrees Fahrenheit, or lower, and that they may increase tremendously at low temperatures in time (see pp. 4, 38). It is safer, therefore, that clean milk be not sold when it is twenty-four hours old; and the requirements of some medical societies certifying milk forbids its sale after it is twenty-four hours old.

The milk arriving in the city on any morning will represent the night's milk of the previous day and the milk which has been milked very early on the morning of its arrival. Or, as in the

writer's experience, the milk arrives in the morning, before 7 A. M., representing the milk of the previous night, while the morning's milk arrives at noon and the delivery of the milk is continued from 7 A. M. to 6 P. M.

In some localities—where night's milk cannot be kept cool—only the morning's milk is sent to the city, the night's milk going to the creamery.

We have found it possible by instructing the customers concerning the folly of demanding delivery of milk to their doors in the early morning hours to, in a measure, ignore this desire, and so distribute milk during the whole of the day, with an intermission of an hour for the men and horses at noon.

Milk consumers should be instructed as to the care of milk at home. That the essentials consist in keeping the milk cold in a covered and absolutely clean utensil.

Thus the milk bottle itself is the best utensil in which to keep the milk. The top and outside of milk bottles should be rinsed with clean water before opening them—unless the inner cardboard cap is covered with an outer paper cap, as certified milk is commonly treated.

The bottle should be kept capped and on ice, unless in a very cold room or in cold water.

Milk should be kept then usually in a refrigerator and away from other foods which easily impart their odor to milk. Covering milk prevents dust and germs and odors from contaminating it.

If milk is received from a can it is well to collect it in a clean, covered, glass preserving jar. Milk should never be left on the doorstep to become warmed by the sun or frozen, as the case may be. Fresh milk must never be mixed with old milk since the latter acts as a starter by adding germs to the fresh supply. Customers should be instructed to rinse milk bottles, as soon as empty, in lukewarm water and not to use them for any other purpose. If scarlet

fever, diphtheria or typhoid fever exist on the premises the milk dealer should refuse to leave bottles or take back any empty bottles.

In such a case milk may be poured from the bottle into a utensil furnished by the customer and left outside the premises for that purpose. The utensil belonging to the customer should not be touched by the milkman.

Customers should be told that all utensils in which milk is kept should only be cleaned by rinsing in lukewarm water, by washing in soap and water, by rinsing in clean water, and finally by scalding in boiling water. The utensil should then be left to drain and dry without touching a towel to it.

It is well for milk producers to supply their customers with instructions to the above effect.

The nature of local conditions will determine to a considerable extent the cost of delivery and also many of the practical details as to the kind of wagon, bottle boxes, use of ice in wagons, etc. To obviate overhauling of the boxes in the wagons they should not be piled in layers one over the other. This may be accomplished by means of a special arrangement in the wagon shown in Fig. 48. I have personally had no experience with this wagon, but have considered that simplicity is one of the chief aims in any scheme, and by making the wagon wide and long enough one can carry about all the boxes of bottles proper on the floor. Thus the wagon body may hold fifteen boxes on the floor and five or more placed directly on top of the first tier without any inconvenience in handling them. These twenty boxes weigh, when filled with milk, bottles, and ice, about 1,400 pounds and constitute a load in a hilly city for two horses. In the wagons built under our direction there is a round hole cut in each side of the top, a few inches above the floor, about fourteen inches in diameter and just back of the driver's seat. This permits of bottles being taken out of the boxes in the wagon without requiring the driver to mount the front of

the wagon. A wide step is affixed to the wagon behind on which the driver stands when getting bottles at the rear of the wagon. The floor is of sheet iron with an open slit at either side running the whole length to permit water draining through the bottom of the wagon. There is a high tail-board, and the upper part of the top of the wagon at the back is closed in for perhaps two feet from the top to keep out the sun. Each of the boxes contains twelve

Fig. 48.

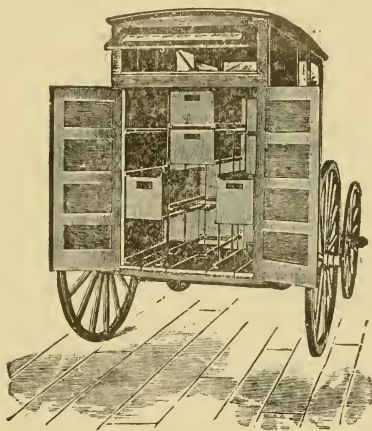

Milk Wagon.

quart milk bottles and the load consists of 240 quarts. The capacity of the wagon arranged for sliding bottle-cases is a maximum of 204 quarts, but special arrangements might allow of greater capacity. A wagon similar to that seen in Fig. 49 may be used for bottles alone and will have a capacity of 256 quarts. The wooden cases slide and may be easily reached from the seat as well as rear. Ice cannot, however, be used on the bottles in this wagon. Such wagons have been used with an ice chamber overhead to

secure cooling of the whole wagon, but with the doors continually open the result in hot weather is far from satisfactory.*

Three sets of bottles are necessary in distributing milk, one remaining at the customer's house, one on the way to and from the farm, and the other at the farm. Two whole sets of bottle boxes are required, one at the farm and the other passing to and fro each day. The delivery baskets (Fig. 50) are convenient in carrying bottles from the wagon to the customer's house.

Fig. 49.

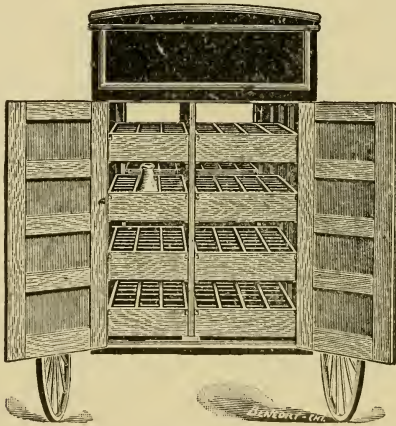

Milk Wagon.

The matter of bottles is an important one. The loss from the customers not returning empty bottles has wrecked many enterprises. The men on the delivery wagons should be required to charge patrons for bottles each day and credit them with returned bottles. Those bottles not returned at the end of the

* These milk wagons are made by the Sycamore Wagon Works, Sycamore, Illinois.

month are charged with the milk on the bill. Some loss of this kind and from breakage is unavoidable until the paper milk bottle comes into general use. The surest way of escaping loss of milk bottles, which is one of the most serious causes of disaster, and also loss in collection, is through the use of tickets. Patrons must be instructed not to place milk tickets in empty milk bottles, as they otherwise will invariably do. The tickets stick to the bottom of the wet bottle and cannot be readily removed by the driver of the delivery wagon. If milk sells for ten cents a quart and a customer begins to take one quart of milk daily he may be sold a package of ten tickets for one dollar. Then the first day two tickets are withheld,

Fig. 50.

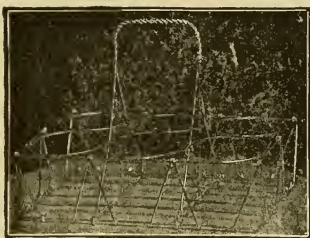

Delivery Basket. A heavier pattern is now sold, made of metal strips, and is more serviceable.

one paying for the milk and the other for the bottle. If the bottle is returned the following day and another bottle of milk is delivered, then the customer gives but one ticket to the milkman. But if the first bottle is not returned, then the milkman takes two tickets the second day and so on. Every returned bottle by a customer means that he receives a ticket or credit for a ticket for each bottle returned. And an empty bottle is regarded of the same value as one quart of milk. If for any reason a responsible customer is out of tickets and cannot pay for more at the moment of arrival of the milkman, the latter gives the customer a package of tickets and requests the customer to sign a regular receipt for same. A bill for the tickets

is then sent at once through the mail to formally notify the customer of his indebtedness.

Another method which has been employed consists in the use of the time-book, made to fit in the pocket, and which the man on the delivery wagon carries. The names of customers in the account book should follow the same order as that observed in visiting them on the milk route. See page 344 for forms used in keeping accounts. This book is ruled so that when the book is opened there are columns on each two pages, facing one another, for all the days of the month. The customers' names are written down in a column on the left-hand edge of the page and his account kept on a horizontal line extending across the two open pages. Two such books are used, the delivery man having one on one day and the other book the following day, so that each day one book may be turned into the office for inspection. On each day two of the perpendicular columns are used for each customer. In the first column is entered the amount of milk or cream taken and in the second column the number of bottles returned. This method is not so good as the preceding. In order to avoid trouble it is necessary for every firm distributing any considerable amount of milk to have a special man who shall be familiar with the customers on each milk route in case of sudden failure of a driver to attend to his duties.

If the milk is to be marketed in the best possible manner, especially if sold for infants' use, there should be placed a parchment paper bottle cap over the ordinary cardboard cap. The object of this extra paper cap, which is waterproof, is to prevent dust, dirt, and water (from melting ice) containing germs from soiling the cap which directly covers the milk. In removing the latter any material on the cap might easily fall into the milk. The parchment paper caps are held in place by a rubber band about the neck of the milk bottle and cost less than one-tenth of a cent when bought in quantity. On them may be printed the day and

month the milk is produced, the name of the farm and the fact that the milk is certified by a certain commission. The certificate

Fig. 51.

**Philadelphia Pediatric Society.
MILK COMMISSION CERTIFICATE.**

September 10, 1907.

Milk from the WAWA Dairy, Delaware Co., Pa., has been recently examined by experts of the Milk Commission and found to be up to the required standards. Another examination is to be made within a month, and, if satisfactory, new labels for the bottles will be issued, dated Oct. 10, 1907.

Notice the Dates. *P. B. A. [Signature]*



Methods of marking parchment caps for certified milk. (Bull. 41 Hygienic Laboratory.)

of the milk commission is often placed between the cardboard and parchment caps. The name of the producer and the fat content

Fig. 52.



Copper case in which caps for milk bottles are placed and then are put in the sterilizer for milk utensils. Sterile caps can be best handled in this holder because they may be removed when wanted for use by only touching their outer edges.

of the milk or cream may be printed on the parchment or tinfoil cap. The best method consists in covering the sterilized cardboard

cap with paraffin over which the parchment cap is placed. By this method milk is prevented from leaking and the cap cannot be removed, or the bottle tampered with, without discovery of the fact. The date on which the milk is to be sold may be stamped with a rubber stamp on the paraffin itself.

The appearance of the men on the delivery wagon is of importance. In this region the use of uniforms of khaki in summer and corduroy in winter has proved satisfactory.

Clean milk is of special value in feeding babies. For this reason endeavor should be made to inform the public of the existence of the opportunity to obtain clean milk by those selling this article, and its use for infant feeding should be made as easy as possible.

The following circular has been used for distribution among the physicians of a city and embodies matter which they may pass on to their patients:

CERTIFIED MILK FOR INFANT FEEDING.

The Dairy desires to call the attention of physicians to the opportunity offered them for not only feeding pure milk to infants, but, by means of analysis of this milk and cream, to prescribe an infant food of known composition.

A dipper is furnished by which the top milk may be removed from the bottle. The upper 9 ounces of the milk contains approximately 13 per cent. of fat when thus removed. One part of this top-milk with 5 parts of water gives Fat, 2.1 per cent.; Proteids, 0.6, suitable for feeding infants from 3rd to 14th day of age. Diluted with 4 parts of water gives Fat, 2.6 per cent.; Proteids, 0.8 per cent.; suitable for feeding from 2nd to 6th week of age. Diluted with 3 parts of water, gives Fat, 3.2 per cent.; Proteids, 1.0 per cent.; suitable for feeding from 6th to 11th week. For feeding from 11th week to 5th month, the upper pint is removed with dipper from the bottle, and diluted with $1\frac{3}{4}$ parts of water, gives Fat, 3.4 per cent.; Proteids, 1.45 per cent. The milk for feeding from the 5th to 10th month is obtained by pouring off the upper pint from the bottle and diluting it with an equal quantity of water. This gives Fat, 4.0 per cent.; Proteids, 2.0 per cent.

Instead of water, barley water, lime water or dextrinized gruels may of course be used as a diluent. Milk sugar may be added in proportion of 1 ounce to 20 of the milk mixture.

The milk is obtained from tuberculin tested and frequently inspected cows, and under the most cleanly conditions pertaining to the animals, stables and para-

phernalia. The milk is drawn into covered pails, through a small aperture in the top, and falls through sterile cheesecloth into the bottom of the pail. It is immediately aerated and cooled, is put into bottles at the farm, and kept on ice until it reaches the consumer. The milk contains nearly 5 per cent. butterfat and averages but 2,000 to 5,000 bacteria to the c. c.

It will not be necessary to pasteurize this milk, and the modified milk mixtures above recommended will be found much superior to dirty milk which has been sterilized and modified. The top-milk should be removed from the bottles on their arrival, and kept on ice, to give good results. This milk is subject to frequent bacteriological and chemical tests by Dr. — and Mr. — at the County Medical Society Laboratory. The formulæ are taken from Holt, as recommended by him for healthy infants, and the following table is also from his book:

SCHEDULE FOR FEEDING A HEALTHY CHILD DURING THE FIRST NINE MONTHS.

Formula.	Age	No. of feedings in 24 hours.	Interval between feedings by day.	No. of night feedings (10 P. M. to 7 A. M.)	Quantity for one feeding.	Quantity for 24 hours.
I	2 to 14 days.....	10	2 hours	2	1-2½ oz.	10-25 oz.
II	2 weeks to 5 weeks....	10	2 "	2	2-3½ "	20-32 "
III	5 weeks to 10 weeks....	8	2½ "	1	3-4½ "	24-36 "
IV	10 weeks to 4 months...	7	3 "	1	4-6 "	28-42 "
V	4 months to 9 months...	6	3 "	0	5-8 "	30-48 "

The reason for diluting cow's milk lies in the fact that the proteids are so much greater in amount in cow's than in women's milk (see p. 47), and also that the proteids in cow's milk are less digestible * than in human milk—for babies. Many recent experiments have apparently shown that this reasoning, which has been generally adopted by physicians, is wrong and that the fat in cow's milk is the indigestible nutrient for babies. It is said that rich cow's milk forms large, indigestible curds in the stomach and that, even in calves, rich cow's milk is less wholesome than skim milk. This latter is a fact. It is further said that rich cow's milk abstracts alkaline salts from the body in order that these salts may saponify and so aid digestion of the fat in the bowels. And again, that this removal of alkaline salts or mineral matter is what brings on scurvy and rickets in babies. This is probably untrue or but partially true.

* In the infant stomach the curd of cow's is much tougher than that of human milk.

However, rich milk is always diluted in proportion to the fat it contains, when properly fed to infants.

The advocates of the theory that cow's proteids are suitable for children recommend that babies be fed on whole skim milk from birth to the end of the first month, and then upon whole cow's milk after that time—providing the cow's milk does not exceed 3.5 per cent. in fat-content.

While this method simplifies feeding of babies, yet it must be appreciated that the chemical and physical properties of fat, lactose and proteids are different in cows' and human milk. Furthermore, actual experience in the feeding of young infants has not proved that this is the best method, as both skimmed milk and whole milk often absolutely disagree with babies during the first months of their life.

One of the chief difficulties physicians have in prescribing milk mixtures for babies is their ignorance of the exact composition of the milk and cream which their patients will use. The milk from the same herds will be of very uniform composition, varying somewhat with the season, but hardly enough to make any material difference in calculations for infant feeding. The dipper used for removing the cream is shown in Fig. 53, and is two and one-fourth inches long and three-fourths of an inch in diameter. It holds a tablespoonful or one-half an ounce of milk, and is used to remove any part of the top milk without mixing the milk with the cream. A siphon (Fig. 53) is also furnished customers to remove the skim milk from the milk bottle. This we find is generally employed and liked by families who use cream on the table, and at ten cents a bottle for milk containing five per cent. of fat the customers get as much, or more, cream than could be bought for this sum and have the skim milk to use in cooking. The siphon, of glass tubing, three-eighths of an inch outside diameter, has a short arm, just long enough ($9\frac{1}{2}$ in.) to reach to the very bottom of the milk bottle, and a long arm five inches longer. The siphon is filled with clean water by holding the shorter arm under

Fig. 53.

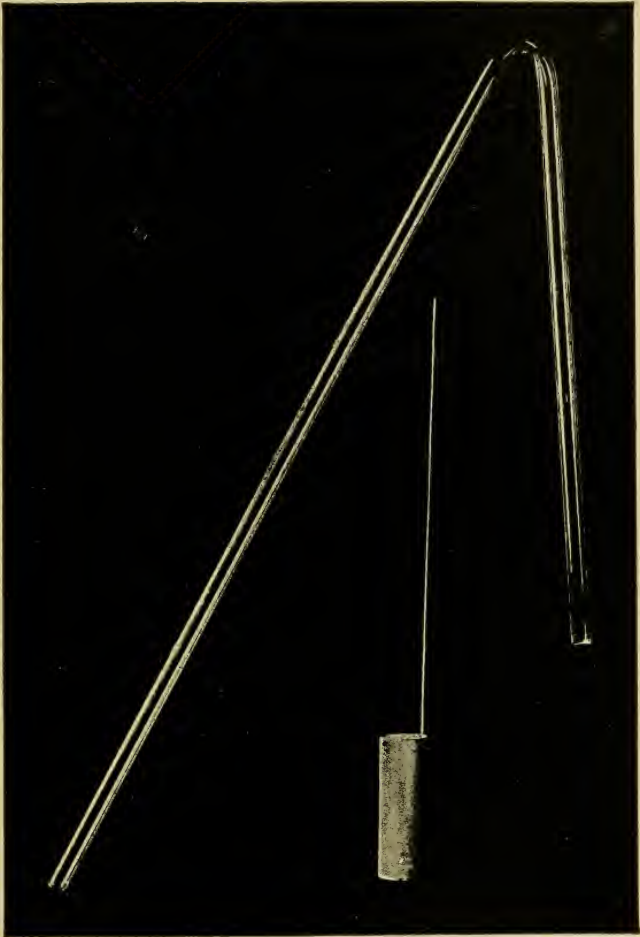

Showing Dipper and Siphon for Removing Cream and Milk respectively.
(See page 172.)

a water faucet, and when the water appears at the end of the longer arm this end is closed by the thumb and the shorter arm is inserted to the bottom of the bottle and the thumb released, allowing the tube to rest in the bottle. First the water flows out and then the milk. The cream gradually settles in the bottle until the lower border of cream touches the bottom of the bottle, when the siphon is at once removed.

A method of distributing clean milk for infants is by means of the infant milk depot, dispensary, or *Goutte de Lait*. These were first established in the United States by Mr. Nathan Straus in New York in 1893. The object is to educate the poor in infant feeding; to supply at a nominal price the cleanest, most wholesome cows' milk in closed bottles containing one feeding (so that the milk cannot be contaminated), and modified to suit the age of infants. The stations are under medical control and in the care of trained nurses who instruct mothers in caring for their children and urge the nursing of babies when it is possible. Many of these depots are open the year round. In some depots raw, certified milk is used; in others the milk is both certified and pasteurized. There were 21 cities having such depots in 1907, four of which were supported by city health boards and the rest by private philanthropy. They are of great educational and life-saving value.

CHAPTER IX

MILK INSPECTION

THE duties and tests of the milk inspector are divided into those performed in and out of the laboratory. Out of the laboratory, the tests are mainly those of the senses. In some cities the collector of milk samples tests the milk for fat and solids by the lactoscope and lactometer (see pp. 197, 203), but more accurate tests may be made in the laboratory. A temperature test is, however, required by most enlightened cities, and when the milk is found to have a temperature above 50° F. it is condemned. The inspector, in taking samples of milk for the laboratory, should thoroughly stir the milk. This may be accomplished by "stirrers," made like the dasher of the old-fashioned dasher churn if the milk is in cans and is to be examined chemically. Milk which is to be examined for bacteria should not be mixed with a stirrer or other contaminating utensil. A special sterile pipette is employed by Boards of Health (see pp. 251-3). A milk bottle may be inverted and well shaken before taking the sample with a sterile pipette or by pouring it from the bottle. Milk in cans may be mixed by pouring it from the original can into a sterile can and back again, or by stirring with a sterile pipette (see p. 253) after shaking.

The bottles in which the milk is placed for bacterial examina-

tion are sterilized by 20 minutes boiling or by sterilizing in a sterilizer.

The corks should be sterilized in the same manner. The bottle must be filled to the cork and packed in a vessel with enough ice to last till the examination is made.

If a sample of milk is taken for chemical examination only, the milk is mixed by pouring it from one bottle or can to another.

In some cities the original bottle is taken for chemical examination (this is best in testing certified milk), but this is expensive because the inspector is encumbered with unnecessary weight and there is loss of milk and bottle to the owner, or to the city, in case the milk is paid for. The two chief reasons for agitating the milk are to thoroughly mix the cream for determining the fat, and, again, to estimate by a bacteriological test the number of germs. In the latter case it is especially important, as ninety-nine per cent. of the germs in milk become entangled in the cream. Two ounces of milk are sufficient for a fat or bacteriological test, and four ounces for a test for preservatives. The inspector seals the corks of the bottle, and, also, should place some sealing wax on the edge of the label, as the labels are often soaked off and placed on a similar sealed bottle. This happens where the inspector is required to give a duplicate sealed sample to the milkman; and the milkman, when he knows his sample is adulterated, may get a sealed bottle given to another milkman (which contains pure milk) and take the label from the adulterated sample and place it on the pure sample. He then brings the pure sample into court with the label number the inspector placed on his adulterated sample and in a bottle with an unbroken official seal on the cork. For full directions for taking samples for bacterial analysis, see p. 251.

Milk may be condemned on account of visible dirt. This is ascertained by straining milk from one can to another through cheesecloth, or by straining only the bottom portions of several

cans.* In Dresden there is a legal standard requiring that the dry dirt in milk shall not exceed 8 milligrammes to the litre (about $\frac{1}{8}$ grain to the quart). The taste may be bad, as from the odor of manure, or from improper feeding, or disease (mastitis) of the cows, and may suffice to condemn the milk. The color may be unusual, as when the cream is highly colored on milk which has been obtained from cows recently calved. Curdling of the milk on boiling will occur if the sample is colostrum. The brilliantly colored milks, caused by special bacteria, are seldom seen in this country. The odor of milk may be bad from various causes, as from improper feeding of the cows, manure in the milk, or from the milk remaining a long while in dirty barns. Sour milk may be condemned. Slimy or stringy milk are not uncommon, but are generally only noticeable several hours after milking, and so usually escape attention until in the consumer's hands. The existence of garget in cows may produce slimy or stringy milk; also it occurs in the milk of cows which have been milked late in the period of lactation; certain herbs are said to cause it. It is somewhat doubtful whether the condition is always due to a special germ (*B. lactis viscosus*; see p. 28) or whether it is caused, at times, by chemical substances (ferments) which occur in certain plants (*Pinguicula*). Fishy milk is caused by rusty cans, and cows inhabiting pastures containing stagnant pools of water may yield milk with this odor or taste.

A General Outline of a Scheme for the Control, Supervision and Inspection of a City Milk Supply

The legal control of a city milk supply is in the hands of the City Board of Health. The State Board of Health should, however, work in coöperation with the City Board through its jurisdiction over the territory from which the milk is obtained. When the milk is drawn from several states this is, of course, of but slight value. Moreover, state supervision is not essential, since the city authorities

* For accurate estimation, see p. 305.

can bring to bear sufficient influence over the producer of unsanitary milk in the following ways: By condemning such when it arrives in the city; by warning or fines; by revoking the license of the dealer in the same in the city; and by requiring that the premises on which the milk is produced be inspected before the milk can be sold in the city.

Supervision of a milk supply must begin at the barn and be continued until the milk reaches the consumer. Thus milk must be inspected at the following points:

1. At the farm.
2. During transportation from the farm to the R. R. or creamery.
3. At the creamery, when this is the shipping point.
4. On the cars during transportation to the city.
5. At the city R. R. or receiving station.
6. On the wagon in the city.
7. At the city dairy, hotel, restaurant, retail store and home of the consumer.

The country furnishing milk must be mapped, the farms and creameries from which milk is shipped must be plotted, and the territory divided into districts, each under the supervision of an inspector living in the region. It has been recommended that there be one inspector to each 100 farms. At present New York City has about 100 inspectors (1907) to supervise some thirty to forty thousand farms in six states and shipping milk into the city from points four hundred miles distant. No milk should be permitted to enter a city until the seal of inspection has been first placed upon it by an inspector in the country.

When milk is shipped from creameries or country receiving stations these form convenient points for inspection and also serve as a base for investigation of the farms supplying the creameries. At the creameries the following demand looking into: (1) The cleaning and sterilization of all utensils; (2) the water supply and

drainage; (3) the temperature at which milk and cream are kept; (4) general cleanliness, requiring the absence of flies and dust.

Inspection of farms is by far the most valuable of all inspections relating to milk. Laboratory examinations in the city will not take its place. Laboratory examinations will not discover any of the special germs most dangerous to man, as those of tuberculosis, typhoid and scarlet fever and diphtheria, or those derived from diseases of the cow—that is the usual routine examination. Hence regular veterinary inspection is indispensable. Cows suffering from disease of the udder, as from the common forms (colon bacillus, streptococcus, or staphylococcus, *B. necrophorous* infection) of mastitis, or tuberculosis, actinomycosis, or botryomycosis, of the udder; or from septic metritis, parturient apoplexy, retained after birth, vaginal discharge, gastro-enteritis, diarrhea, constipation, suppurating lesions, foot rot, necrosis, tetanus, fever, mange, or any severe constitutional disease, or cows recently with calf or about to calve, should be debarred from supplying market milk and the sick animal should be removed from the barn in most cases. Not only this but if any contagious disease exists among cows, as tuberculosis, foot and mouth disease, black quarter, cow pox, milk sickness, anthrax, lung plague, septic enteritis or mastitis, or septicemia or rabies—the milk of the whole herd should be refused and, after the disease is past or the cows removed, the premises must be thoroughly disinfected (see p. 346).

It is wiser that all inspectors of farms should be veterinarians and they should have had previous training in the production and handling of clean milk. Some authorities state that half the farm inspectors should be veterinarians and the rest trained dairy inspectors. The frequency of examination of farms depends upon the results of bacteriological examinations of milk. The farms supplying the dirtiest milk need the more frequent inspections. Inspections should be made once a month if possible. Certified milk farms should be inspected weekly. The veterinary inspector must rely partly on the information given him as well as upon his obser-

vation. Thus he cannot examine all occupants of the farm for contagious disease, as he is neither empowered nor competent to do so. Again he may not be able to be present at milking time, although this is almost essential to make a proper inspection. The form on which the inspection is written (see pp. 209, 210) will be made in quadruplicate, *i. e.*, the original and 3 carbon copies. One is to be retained, one is sent at once to the city health office, one to the city retailer, and one is given to the farmer. The standard of marking the inspection blank is of importance. Thus Health Officer Woodward says that if the standard is perfection, a total percentage of 30 should enable a farm to pass muster; but, if the standard is only one which might be reasonably expected of the present-day, progressive dairyman, then a total of 70% should be required.

If the farm is not up to the standard the inspector must notify the farmer that he will take his permit away (see p. 208) if the requirements are not fulfilled. If the farmer is outside of the legal authority of the inspector then the city dealer in the milk will be notified by the inspector, through the city health office, that his permit will be revoked unless he ceases to purchase the milk from the delinquent farmer.

It is usually the custom to give the producer fair warning and an opportunity to repair his shortcomings rather than to immediately invoke the aid of the law. If the milk is subject to infection from contagious disease its sale will be at once stopped by the inspector. I quote the following from Dr. Woodward of District of Columbia, to whom I am much indebted for information concerning milk inspection:*

“Each inspector of dairy farms files with the health officer, daily, a report of his operations for the preceding day. In addition to this he keeps his own record of outstanding notices, and as soon

* See Bull. No. 41, Hygienic Laboratory, U. S. Surgeon-General's office.

as practicable after the expiration of the time allowed for the correction of objectionable conditions, he visits the premises to see whether the notice has or has not been complied with. If it has been, the inspector makes report accordingly. If it has not, he takes action to enforce compliance. He may immediately serve a notice requiring the licensee to show cause, satisfactory to the health officer, why his permit (to ship milk) should not be canceled. Or he may recommend that a letter of that purport be written by the health officer. Or, if the farm be located in the District, he may recommend immediate prosecution in the police court, and with the approval of the health officer he may institute such prosecution. If a licensee has been notified to show cause why his permit should not be canceled, and has failed to do so, or has shown no sufficient cause, then the health officer cancels the permit and notifies the licensee and his consignee or retailer, if he have one, that such action has been taken. If thereafter the milk from that farm is brought into the District the person at whose instance it is brought is prosecuted in the police court."

The farms need inspection in regard to the ensuing matters:

Cows.

1. Whether tested with tuberculin.
2. Cleanliness.
3. Whether affected with udder or other disease. Isolation of diseased animals.
4. Amount of exercise.
5. Food. Kind and time of feeding.

Barn.

1. Cleanliness.
2. Ventilation.
3. Light.
4. Removal of manure.
5. Drainage and cleanliness of surroundings.
6. Use of small-top milk pail.

Methods of Milking.

1. Health, cleanliness and clothing of milkers.

Milk Rooms.

1. Cleanliness of premises. Presence of dust or flies.
2. Health and cleanliness of employees.
3. Purity of water and ice supply.
4. Method of cooling milk.
5. Method of keeping and storing milk.
6. Method of washing and sterilizing utensils and care of the clean utensils.
7. Method of filling bottles or cans.

Transportation.

1. Care and cooling of milk on wagons, at station or creamery, on railway, and at receiving station.
2. Washing of returned empty utensils.

Insistence should be gradually made that cows supplying market milk should be tuberculin-tested. Now Grand Rapids, Mich., Minneapolis, Montclair, N. J., Colorado Springs and Pasadena are supplied with milk from tuberculin-tested cows.

Dr. Goler, of Rochester, N. Y., also recommends, in case the territory supplying a city is large, the establishment of one or more laboratories in the country as sub-stations for the work of milk inspection. This might be conveniently carried out in connection with creameries.

Country inspectors should not only perform their police duties, but should act as teachers and should talk, and distribute printed matter, concerning everything which relates to the production and care of sanitary milk.

The plan adopted by the Massachusetts Board of Health, in publishing a monthly list of well conducted and cleanly farms, is to

be recommended. Goler urges the establishment of model dairy farms by the state in connection with the laboratory substations in the country, the scheme comprising the remodeling of some old and run-down farm, so that in its upbuilding the farmer could apply the same measures to his own premises.

In regard to the transporting of milk on the railroad—railways carrying milk to the large cities of the country now supply refrigerator cars for milk, with adequate icing facilities to cool milk below 50° F., in most cases. When such refrigerating arrangements are not obtainable, milk and cream should be shipped as advised on p. 123.

Inspection on the cars is limited to taking the temperature of milk. At the receiving station in the city there must be daily inspection with reference to the temperature of milk, to the care of cans and bottles of milk while *en route*, and to the condition of empty bottles and cans which are being returned. The inspector shall here examine milk by sight, smell and taste (see p. 176), and by lactometer and lactoscope (if such be the custom), and take samples for laboratory examination. According to the writer's views, the only accurate testing which should be done by the collectors of samples is that of temperature taking. Testing for the solids and fat and for adulteration and bacterial content can be done much more accurately at the laboratory.

During distribution of milk by wagon in the city, inspection is desirable to ascertain that the milk is properly iced in warm weather, that the temperature of the milk is kept below 50° F., that bottling of milk is not done on the wagon, and that general cleanliness of utensils and wagon is observed. Samples of milk should be taken from each wagon at least once a month for laboratory examination.

A sample of milk should be taken from each retail store every month. Milk in the various stages of transportation from cow to consumer becomes more germ-laden through age and handling.

especially when poured from one utensil to another, and the case of the retail shop is the worst. This has been strikingly shown by Prof. J. O. Jordan, of Boston. The legal limit for bacterial content in Boston is 500,000 germs to the c. c. The milk during 1906, in respect to this standard, was found to be distributed as follows: On the cars, on arrival, 90 per cent. fulfilled the requirements of the germ standard (*i. e.*, containing less than 500,000 bacteria); on the wagons, 50 per cent. complied with the germ standard; and in the retail stores, only 18 per cent. complied with the germ standard. Such a difference between the quality of milk on arrival and subsequently does not occur in milk bottled at the farm, cooled immediately below 50° F. and kept at that point all the time until it reaches the store customer. Only bottled milk should be sold in stores, and the bottling should be done at the farm, or, less favorably, at the creamery or city dairy. Inspection at stores must enforce requirements for a proper refrigerator and cooling of the milk, and also that the store be apart from dwelling-rooms.

Infectious disease in the person of workers in farms, dairies, milk shops or stores selling milk, or in the person of anyone living on the premises, should lead the inspector to close any shop for the sale of milk until such time as the infection is past and disinfection done. Any person suffering from infectious disease—or having had contact with a patient having such—should not be permitted to handle milk in a city dairy or other place where milk is kept or offered for sale.

In the inspection of city dairies, stores, hotels and restaurants, the proper cleaning of empty cans and bottles should receive special attention. In many cities an ordinance requires that milk cans and bottles must be thoroughly cleaned or sterilized before their return to the farm or creamery. Also an ordinance should forbid using utensils employed for transporting milk and cream as receptacles for any other material whatsoever. Jordan notes that broken eggs,

coffee, oil, chocolate, molasses, blood, and, above all, kerosene, are not infrequently discovered in milk cans.

At each city dairy the cleanliness of premises and milk utensils, the purity of the water supply, and the facilities and method of cooling milk and cream should be the subjects of inspection. Samples of milk should be taken from the city dairy at least once monthly.

Contact of the human body with milk always opens up an opportunity for the transmission of typhoid, diphtheria and scarlatina organisms to milk. This danger is most real in milk-tasting by those sampling cans through dipping of the fingers, licking the stoppers or in the use of spoons. Tasting should only be done by means of sterile utensils and to best advantage by those of paper, cardboard or wood, which should be discarded after a single use. Other utensils—as spoons—should be washed and boiled after a single use before being used a second time. In the handling of milk the hands must be dry and clean, to avoid any dripping from the hands into the milk.

Regulations embodying such requirements are now a part of the rules enforced by some municipal Boards of Health and are essential.

In the inspection of city dairies, or places where milk is handled and sold in the city, the force may both inspect and collect samples; or part of the force may inspect and part collect samples.

The law is enforced by giving delinquents notice (see p. 208) to show why their permit should not be revoked. A copy of this permit is retained and another sent to the health office. In some cases of flagrant disregard of the law the inspector may begin action at once.

A score card for city dairies (see p. 211) is used by the inspector.

One copy is given the owner and one is filed in a compartment used for all papers pertaining to the same dairy. On the score

card the inspector should state that all requirements have been complied with, or that proper steps have been taken to correct unlawful conditions.

A form for the collector of samples and chemist is also submitted (see p. 215). In taking samples, one is given to the vendor (see p. 175) and one is immediately analyzed in the laboratory. If found below the standard, prosecution is begun by the analyst. The collector identifies the sample and the chemist or bacteriologist testifies to its composition and bacterial content.

Results of laboratory findings are kept in a card catalogue. If the legal standard requires 3.5% butter fat, the inspector may use some discretion in prosecuting a delinquent on the first offense. Various justifiable reasons may exist for a low butter-fat content, as insufficient mixing of the milk, or breed of cows. Prosecution may be at once begun if the fat-content falls below 3.25%, or if the milk is watered, artificially colored, or contains preservatives.

In regard to contagious disease in its relation to milk inspection. The health office may be supplied with information as to any relation between contagious disorders and milk supply if physician's reports are required to contain the names of milkmen supplying milk to patients prior to their sickness. Or, in some cities, the milk inspector gets this information for the health office by visiting the premises of all reported infections. The health office should then serve a notice on the dairyman not to supply any more milk in bottles to the infected premises until quarantine is raised. Milk may be left in some utensil supplied by the owner of the premises but no return milk utensil must be taken by the milkman. Again, if there is a suspicious number of cases of contagious disease on the route of any one milkman, the health office should proceed to investigate the sources of the milk supply and health of those handling the milk. The veterinary inspector should conduct this work in the country, and the contagious-service, health

officer in the city. If it is found that the milk is exposed to infection, its sale should be at once stopped, unless the source of infection can be immediately removed.

Inspection of milk at hotels and restaurants should be directed toward enforcing the ordinances as regards temperature of milk, cleanliness of utensils and the sale of skim milk. Samples should be taken once a month from hotels and restaurants.

The proper care of milk after it has reached the consumer is the most difficult matter of control and can only be managed by general education of the public. The Board of Health, through its monthly bulletins, and those selling clean milk may supply the public with information on the subject, and consumers should be fined for not returning empty milk bottles or cans properly cleaned.

In Boston the wholesale milk dealers are exceptionally progressive. They assist the health authorities by taking the temperature of milk consigned to them, by straining milk to discover dirt, by cleaning empty cans; while six dealers (1907) have actually installed bacteriological laboratories for their own use (Jordan).

A sufficient number of inspectors or collectors of samples in cities may require one to each 50,000 of population. In addition to the duties described above, the city inspector should examine the premises of applicants for a city license to sell milk, before one may be issued.

The City Board of Health should publish in a monthly report the names of each dairyman, dividing them into four categories: those selling Certified, Inspected, Ordinary Market and Pasteurized milk; and should report the number of bacteria in each. Also notice of any dairyman who has been found guilty of infractions of any of the ordinances pertaining to milk should be thus publicly announced.

A. D. Melvin, Chief of the Bureau of Animal Industry, suggests that the following division be made of the milk composing a city supply: 1. Certified milk. 2. Inspected milk from tuber-

culin-tested cows housed, fed and milked under good conditions with a maximum content of 100,000 germs per c.c. the year round, and shipped in sterilized containers at the farm at a temperature below 50° F. 3. All other milk should be pasteurized (as soon as practicable after milking, from 10 to 40 minutes according to the temperature, see p. 218), cooled immediately to 45° F., and sold at a temperature below 50° F. Clarification, and pasteurization should be done at a central plant in sterile, closed vessels, preferably the final containers, and under the personal supervision of a health officer. It will be a long time before proper pasteurization is accomplished in most cities and until such time is come it will be much wiser for persons to pasteurize their own milk supply at home (see p. 13). It should be required by law that pasteurized milk be marked with labels stating precisely the date and degree of temperature at which the milk was heated and the time during which the milk was kept at the given temperature. In New York City a permit to sell pasteurized milk is necessary under the following requirements: After pasteurization the milk must be at once cooled and placed in sterile, sealed containers plainly labeled "pasteurized," and so delivered to the consumer. The labels must bear the permit number, the date and hour when pasteurization was completed, the degree of heat employed and the time exposed to the heat. Pasteurized milk must be delivered within 24 hours of the pasteurization and no milk shall be pasteurized a second time. For more precise municipal requirements for pasteurized milk, see p 216).

Milk which is only fit for pasteurization should also be clarified (previous to pasteurization) by passing it through a separator, moving at low speed, to remove the dirt and so improve the flavor and appearance of the milk (see p. 56).

Skim milk, buttermilk, and cream should be labeled as such, and the percentage of fat in cream should be stated on the label and also whether it is pasteurized (as in the case of milk).

Milk Preservatives

The most commonly used preservatives are formaldehyde, borax and boric acid. Occasionally salicylic acid and sodium carbonate are employed. Formaldehyde may be detected, during the process of determining fat by the Babcock test, by observing the color of the line of contact of the acid with the milk. When pure milk is used for the Babcock test, the color of this line is dirty brown, but, when formaldehyde is present in the milk, a distinct purple hue will appear at the junction of the acid and milk.

This test may be applied in other ways by using a separate sample of milk. Place about 20 cubic centimeters* of milk in a small glass vessel, dilute with an equal volume of water, and add commercial sulphuric acid, allowing it to flow slowly down the inside of the vessel. If formaldehyde is present the purple color will appear at the junction of the acid and milk.

Boric acid or borax are detected by adding to a few drops of milk, contained in a white dish, a drop or two of hydrochloric acid, and then several drops of a saturated alcoholic solution of turmeric. Heat the dish gently for a few minutes and, if boric acid or borax are present, a pink or dark red color will appear. Cool, and add a drop of ammonia, when a dark blue-green should be seen.

Sodium carbonate is detected by adding to the suspected sample of milk an equal volume of alcohol and then two drops of a one % solution of rosolic acid. If sodium carbonate is present a red-rose color will appear. The test may be performed with more certainty if a comparison test is made with a sample of milk known to be pure.

Salicylic acid is rarely used, but may be detected by adding a few drops of sulphuric acid to a small quantity of milk and then

* A cubic centimeter (metric system) is a volume of fluid equal to 16 drops of water. Any apothecary can prepare the substance required to make the above tests and at the same time could perform the tests with the assistance of the description given above and show the farmer or dairyman how to perform them himself.

shaking gently with a mixture of ether and petrolic ether. The mixture is made of equal parts of ether and petrolic ether and equal volumes of acidulated milk and ether mixture are taken. Then, after standing for several hours, the upper ethereal solution is poured off and the remaining liquid is evaporated in a porcelain evaporating dish. Add, to the residue on the white evaporating dish, a few drops of water and, if salicylic acid is present, a drop of ferric chloride solution will produce a violet or purple color on being added to the solution.

It sometimes happens that it is desirable to determine whether milk has been heated to 176° F. or over. To test this (Storch's test), add to 5 cubic centimeters of milk 2 drops of a freshly prepared 2 per cent. solution of Paraphenylenediamine hydrochloride or meta-di-amido-benzene chloride, and then one drop of a 2 per cent. solution of hydrogen peroxide. Unheated milk gives a blue color when thus treated, but milk heated to 176° F., or over, gives no color.* This test depends upon the action of the ferments or peroxidases, normally present in milk, inducing oxidation of meta-di-amido-benzene by means of hydrogen dioxide with the production of a blue color.

When milk is heated to, or over (80° C.) 176° F., the ferments are killed and the blue color is absent.

According to different authorities the temperature of the milk, at which the blue color disappears, varies from 75° C. (176° F.) for 2 minutes (Storch), to 80° C. (see p. 216).

The simplest test for preservatives is to place some milk in a warm place (at temperature of 80° to 90° F.) in a corked, clean bottle for 24 hours. If it does not sour or curdle, the addition of a preservative may properly be suspected, unless the milk has been

* If the milk at once becomes indigo blue, or the whey violet or reddish brown, then the milk has not been heated—or not heated above 172.5° F. If the milk turns bluish gray immediately, or within one-half minute, it has been heated to 174.2° F. The test should be done on an unheated specimen along with that on the suspected sample.

pasteurized. The tests described on pp. 188-9 may then be tried to determine positively the presence or absence of preservatives.

For testing the acidity of milk, an alkali and phenolphthalein are commonly employed. The basis of this test rests on the fact that phenolphthalein turns pink in the presence of an alkali and is colorless in the presence of acid. Therefore in the tests, by adding a known quantity of alkali to a known quantity of milk and phenolphthalein, we may know just how much acidity is present in the milk. For when enough alkali has been added to the milk and phenolphthalein to turn the mixture pink, we know that all the acid in the milk has been neutralized and the mixture is becoming alkaline.

Roughly speaking, increased acidity in milk means increase in number of lactic acid bacilli. The degree of acidity is commonly tested by health boards in cities to determine the fitness of milk for food. But, as has been recently shown by Bergey, the acid test will not apply to pasteurized milk. There may be hundreds of millions of germs in pasteurized milk without marked acidity. This happens because the germs are not of the acid forming type but belong chiefly to the hay bacillus group (*B. subtilis*).

These are not usually rated as disease germs, but they make the milk less digestible and nutritious and may produce substances in the milk which cause severe vomiting and diarrhoea in infants.

By far the easiest and most convenient method of testing milk or cream for acidity, for those not versed in chemistry, is by means of (Farrington's) alkaline tablets, which may be had of any wholesale dairy supply company. Milk which contains more than 0.2% of acid (lactic acid) is not considered sweet, and the acidity of sweet cream varies from 0.15 to 0.2%. The Farrington tablet contains an alkali and phenolphthalein. Two tablets are dissolved in 1 ounce of water and this is added to an ounce of milk. If the mixture remains pink, then the milk contains less than 0.2%

of acid, but if the pink coloration fades and disappears it shows that the mixture contains more than this amount of acid and is unfit for retailing, for pasteurizing, or for cheese or butter making. A more exact method of using the tablets for testing the acidity of cream may be done. This is very useful for the butter maker in informing him of the progress of the ripening of cream, and also in showing whether or no two lots of cream may be mixed safely, and again it may be used to test the acidity of whey. When cream contains 0.5 to 0.6% acidity, it is as sour as it should be for butter making. Full directions for use of the Farrington alkaline tablets are supplied with the tablets.

A test by which the percentage of acidity of milk may be more accurately determined than is necessary by the dairyman, is that in which the alkali is lime water.

To make lime water, used in testing the acidity of milk, we may get from a grocery store an ounce or so of lime; add a pint of water, and stir thoroughly. Allow the undissolved lime to settle, and pour off the clean lime water, which will contain any potassium or sodium that may have been present in the lime. Do this several times. Now pour on a quantity of distilled water depending on the sized bottle the lime water is kept in, and cork; when the lime has settled so the water is clear, it is ready to be used and may be removed as wanted with a pipette, as will be described presently. Always have some undissolved lime at the bottom of the jar, as by this means the lime water is readily kept saturated. As fast as the lime water is used, add distilled water to take its place. It is well to use a fresh lump of lime every two or three months, as in time the sediment may consist of carbonate of lime, owing to absorption of carbonic acid from the air.

To test the acidity of milk * with lime water: (1) First mix the milk thoroughly, and (2) with a graduated 1 c. c. pipette (such as is shown in Fig 41) place 1 c. c. of the milk in a small

* This test is taken from Chapin's Theory and Practice of Infant Feeding.

evaporating dish or test-tube. (3) To this add one drop of an alcoholic solution of phenolphthalein (1 gm. to 30 c. c. alcohol). (4) With another 1 c. c. pipette add drop by drop clear lime-water, and shake the tube to mix thoroughly, until the milk is colored a faint pink. Now note how many c. c. of lime-water were used.

1 c.c. milk and phenolphthalein colored by	0.1 c.c. lime-water	.045 p. c. acid.
I " " "	.2 " "	.09 "
I " " "	.3 " "	.135 "
I " " "	.4 " "	.180 "
I " " "	.5 " "	.225 "
I " " "	.6 " "	.270 "
I " " "	.7 " "	.315 "
I " " "	.8 " "	.360 "
I " " "	.9 " "	.405 "
I " " "	1.0 " "	.450 "
I " " "	1.1 " "	.495 "
I " " "	1.2 " "	.540 "
I " " "	1.3 " "	.585 "
I " " "	1.4 " "	.630 "
I " " "	1.5 " "	.675 "

A simple rule is: Multiply 0.0045, the weight in grams of lactic acid neutralized by 1 c. c. lime-water, by the number of cubic centimeters of lime-water used, and divide by 100, which gives the percentage of acidity.

Cream Thickeners.—Viscogen, a solution of sugar, lime and water, is commonly used to thicken cream. This adulteration can only be determined by a chemist, making an exact analysis for sugar and estimating the percentage of lime. Gelatine is sometimes employed as a thickening agent. This can be detected by adding, to about 10 or 15 cubic centimeters of milk, twice the volume of water and 10 cubic centimeters of acid mercuric nitrate solution (10%). Shake the mixture vigorously and allow it to stand a few minutes and filter. If much gelatine is present it is impossible to filter a clear fluid. To verify a suspicion of gelatine, add to a small amount of the filtered fluid an equal volume of a saturated aqueous solution of picric acid. If any gelatine is present, a yellow cloudiness will appear in the fluid.

Milk which has been either watered or skimmed, or both watered and skimmed, is considered according to law to be adulterated and is the commonest form of adulteration. To determine whether milk has been watered or skimmed (p. 204) three determinations are necessary: viz., the determination of the total solids in milk; fat; and the specific gravity. For the determination of the specific gravity and approximate determination of milk solids, see pp. 197-203. The determination of the fat alone is usually sufficient to estimate the quality of milk for the farmer who does not adulterate his milk.

Fig. 54.

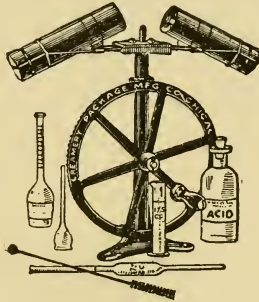

Small Babcock machine, with other necessary paraphernalia.

The methods for determining accurately the amount of fat* in milk are based upon centrifugal separation of milk. The theory of these methods depends upon the fact that when milk is whirled at a rapid rate—several thousand revolutions per minute—the heavier portions of the milk are thrown outward, leaving the lighter or fatty portions nearer the center of the whirling body. The method of Dr. S. M. Babcock is the one in general use.

The milk is measured in a suitable bottle and an equal volume of sulphuric acid is added which dissolves the casein or curd of milk and liberates the fat. The bottle is then whirled at a high speed, allowing the fat to come to the top of the bottle—that is, as the

* For approximate determination of fat and solids in milk, see p. 204.

bottle is nearly horizontal when whirled, the fat approaches nearest the centre of the whirling body. Hot water is added and the bottle

Fig. 55.

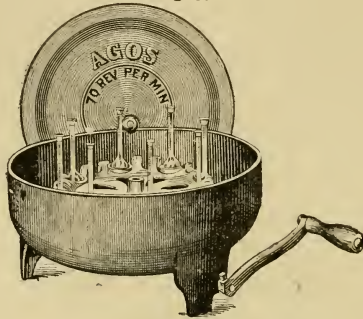

Eight-bottle Babcock machine.

whirled again and the percentage of fat is read off in the neck of the bottle.

Fig. 56.

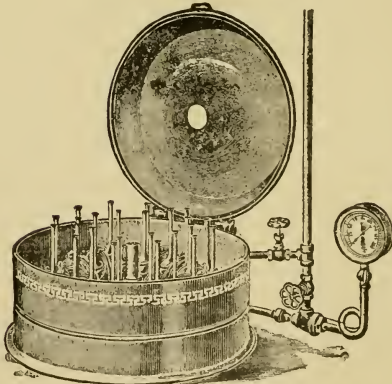

Power Babcock machine.

The Babcock centrifugal machines are obtainable in sizes ranging from those holding two bottles (Fig. 54) to those holding 24 (Figs. 55 and 56), and the smaller are run by hand while the larger

are often run by power (see Fig. 56). The smaller sizes may be clamped or screwed to a table, require but little space and are easy to operate. The Babcock bottle for milk-testing (Frontispiece) holds about 40 cubic centimeters, the neck is graduated from 0 to 10 with sub-divisions of 0.2 per cent.—2 cubic centimeters being the exact volume of the space between 0 and 10—or 10% of 20 cubic centimeters, which volume of milk would be used had milk and melted fat the same specific gravity as water. It happens, however, that 2 cubic centimeters of melted fat weighs 1.8 grams, so in working with the test, 17.6 cubic centimeters of milk (the average volume of 18 grams of milk) are used. It is apparent then that the subdivisions on the stem of the bottle read per cent. direct. To illustrate: Suppose a given sample reads 5 on the neck, the volume occupied by this fat would be just one cubic centimeter and that would weigh 0.9 grams, and 0.9 grams equal 5% of 18 grams, or the per cent. of fat by weight in the milk.

To make the test: The milk should be well mixed, and both it and the acid should be at a temperature between 60° and 70° F. The pipette, graduated to 17.6 cubic centimeters, should be filled precisely to this point, by sucking up the milk into it. The milk bottle is to be held in a slanting position and the point of the pipette just introduced into the neck of the bottle (see Fig. 58). By gradually raising the finger from the end of the pipette, the milk is permitted to flow into the bottle, the last drop being expelled by gently blowing through the pipette. To the milk in the test bottle, 17.6 cubic centimeters of commercial sulphuric acid (specific gravity 1.82) are added in the same manner with the pipette, and, by gently rotating the bottle, the acid and milk are mixed.

The acid and milk become very hot and care must be taken to mix gradually, and to allow no lumps to collect in the neck. It is well to then let the bottles stand for a few minutes, and mix again by rotating the bottles.

The bottles are now placed in the machine (it is wise to have

duplicates of each sample of milk) and the machine is rotated at full speed for five minutes. Then the machine is stopped and boiling soft water is added to the contents of each bottle, by means of the pipette or otherwise, till the contents of the bottle rise to the

Fig. 57.



Fig. 58.

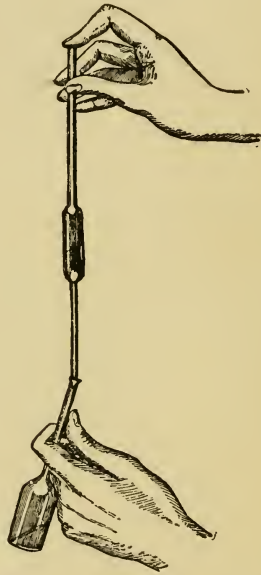

Pipette for making the Babcock test. Shows method of introducing milk into Babcock bottle with pipette in making the fat test.

lower end of the neck of the bottle. The machine is whirled at full speed again for two minutes. More boiling water is then added to the contents of each bottle by pipette until the fat rises in the neck to the 8 or 9 mark. The machine is once more turned one

minute and the percentage of fat is read off in the neck of the bottle by measuring with calipers from the lower to the upper border of the fat in the neck. The reading must be done before the contents or the bottle cool off. The addition of the hot water may be accomplished without removing the bottles from the machine (see Frontispiece).

Estimation of Solids in Milk by Quevenne's Lactometer

Since most cities require that market milk shall contain a standard percentage of milk solids, it is of advantage that the farmer be able to determine this matter for himself.

Quevenne's lactometer (Fig. 59) is an instrument by which the solids can be roughly estimated. It consists of a glass bulb weighted with mercury and terminating in a stem like a thermom-

Fig. 59.



Quevenne's Lactodensimeter or Lactometer.

eter, and marked by lines on the stem from 15 to 40. It should also carry a thermometer.

The principle upon which the lactometer is based depends upon the fact that, when it is placed in milk, in floating it displaces a bulk of milk equal in weight to the weight of the lactometer. The milk must be thoroughly mixed—but free from bubbles of air—and the reading is taken at the actual level of the milk; not at the point of the stem to which it is drawn by capillary attraction.

The lactometer is then used to determine the weight of milk (or in other words, the specific gravity) as compared with the weight of an equal bulk of water when both are at the same temperature.

If 1,000 is taken as the weight of a certain quantity of water, the weight of the same quantity of milk, at the same temperature,

is about 1,030 to 1,034. This is shown in practice by floating the lactometer in milk, placed in a cylindrical glass tube, when it will sink in the milk to a mark on the stem corresponding to the specific gravity of the milk. The greater weight of milk (as compared with water), or its specific gravity, is due to the solids-not-fat it contains, *i. e.*, the casein, albumin and milk sugar. While the lactometer may be used to determine the solids in unaltered milk as it comes from the cow, it will not determine the solids in milk which has been watered and skimmed. Milk fat weighs less than water, and, of course, less than milk. Removing cream raises the specific gravity of milk. Then if water were added the specific gravity might be lowered again to the normal for untampered and unadulterated milk.

To estimate the solids in milk by the lactometer, the temperature of the milk should theoretically be 60° F. But the milk may be at any temperature between 50° and 70° F. providing a correction is made for the temperature of milk above or below 60° F. Thus, if the milk is above 60° F., one must add to the lactometer reading 0.1 for each degree of temperature above this point; if the temperature of the milk is below 60° F., one should subtract 0.1 from the lactometer reading for each degree of temperature below this point. For example, if a sample of milk at a temperature of 65° F. shows a lactometer reading of 29, then one should add to this reading:— $5 \times 0.1 = 0.5$, which gives the corrected reading as 29.5. If, on the other hand, the lactometer should float in milk to a mark on its stem indicating 29, and the temperature of the milk was 55° F., then one should subtract 0.1 for each degree of temperature below 60° F. from this lactometer reading, which gives us 28.5 as the corrected reading.

Now, to estimate the solids in milk we must have previously determined the percentage of fat in the milk by means of Feser's lactoscope or the Babcock machine. To find the total solids in milk we divide the lactometer reading by 4, and, to the result, add

the per cent. of fat multiplied by 1.2. For example, we have a milk containing 4 per cent. of fat and a lactometer reading of 32, to find the total solids:

$$\begin{array}{r} 32 \div 4 = 8. \\ 4 \text{ per cent.} \times 1.2 = 4.8 \\ \hline 12.8 \text{ per cent. of total solids.} \end{array}$$

To find the solids-not-fat, divide the lactometer reading by 4, and, to the result, add the per cent. of fat multiplied by 0.2. Thus, in the same milk as in the last example:—

$$\begin{array}{r} 32 \div 4 = 8. \\ 4 \text{ per cent.} \times 0.2 = 0.8. \\ \hline 8.8 \text{ per cent. of solids-not-fat.} \end{array}$$

The percentage of casein and albumin increases—though not in a proportionate degree—with the increase of fat, as shown in the following table from Woll's Handbook, summarizing the analyses of 2,400 samples of milk:

Fat per cent.	Casein and albumin	Total solids	Fat per cent.	Casein and albumin	Total solids
3.07	2.92	11.00	4.68	3.57	14.00
3.29	3.0	11.50	4.92	3.79	14.50
3.50	3.07	12.00	5.38	4.00	15.00
3.75	3.19	12.50	5.69	4.15	15.50
3.99	3.30	13.00	6.00	4.30	16.00
4.34	3.44	13.50			

Van Slyke gives the following formula for computing the casein-content from the known fat-content in milks containing from 3 to 4.5 per cent. of fat: Subtract 3 from the per cent. of fat in milk, multiply the result by 0.4, and add the result to 2.1. Hart has shown that the proportion of fat to casein is not at all constant, particularly in the milk of cows containing a large amount of fat. In order to determine more accurately the percentage of casein in milk the simple test recently given to the world by Prof. E. B. Hart is of great value.

The Hart casein test depends upon the following principles: 1. Construction of tube and scale whereby percentages of casein in the milk are read directly. 2. Establishment of a proper volume

of milk to be used that will conform to the tube and scale adopted, allowing percentage of casein to be read directly. 3. The precipitation of the casein by dilute acetic acid. 4. The agitation of the precipitate with chloroform to remove the fat. 5. The application of a definite centrifugal force in order to mass the casein into a pellet. 6. Reading the per cent. of casein.

Special tubes (Fig. 60) made by E. H. Sargent & Co., Chicago, are used. The tubes are $5\frac{1}{2}$ inches long and graduated so that each division on the scale = 0.2 per cent. of casein when 5 c. c. of milk are used in the test. A centrifuge is used with a revolving wheel 15 inches in diameter and giving 2,000 revolutions per minute. A 20th Century Babcock fat tester, made by the Creamery Package Co., Chicago, may be employed. It is necessary that the diameter of the machine and the number of revolutions performed shall be exactly as directed. The pockets for the tubes are made especially for the casein tube and the bottom of the pocket is cushioned from the graduated part of the tube by inserting the ends of the graduated tubes into holes bored out for them in corks (see Fig 60). 20 c. c. of glacial acetic acid in 0.25 per cent. solution is used for each tube. The test: Place tubes in a rack, graduated-ends down. Drop 2 c. c. of C.P. chloroform into each tube; then on top of the chloroform, drop 20 c. c. of the acetic acid solution at approximately 70° F. Then add 5 c. c. of milk by pipette at temperature ranging from 65° - 75° F. Shake mixture with thumb over aperture of tube for 15 to 20 seconds by the watch. Place tubes in the centrifuge and rotate. When machine is revolving 2,000 revolutions per minute keep this speed for $7\frac{1}{2}$ to 8 minutes, and remove the tubes to a rack with graduated ends down.

To secure correct number of revolutions, buy a metronome at a music store. Then count how many revolutions of the wheel occur for each turn of the crank. Thus 1 turn of crank = 36 revolutions, then 55 turns per minute = 2,000 revolutions per minute. The metronome is set to audibly beating this time, *i. e.*, 55 beats per

minute so that one can follow it and turn the crank once for each beat. After tubes have rested in the rack 10 minutes the readings may be made. At the lower end the chloroform, then the white mass of coagulated casein, and above the clear solution of other solids are seen (Fig. 60). To read: Hold the tube perpendicularly at level of the eyes and note the divisions marking the higher and lower levels of the casein. To find the percentage count the divisions between these levels, or subtract the lower from the higher level.

Fig. 60.

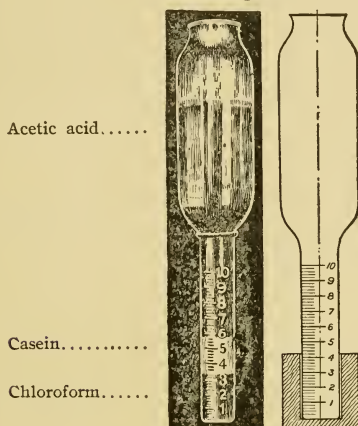

Tubes for Hart's Casein Test.

If a preservative is used in the milk, only potassium dichromate is suitable—1 tablet to each 10 ounces of milk, and the sample should not be over 3 or 4 days old.

The New York Board of Health lactometer has a scale divided into 120 equal parts.

One hundred on this scale corresponds with a specific gravity of 1.029, which is falsely supposed to represent the minimum specific gravity of pure milk; while 0 on the scale equals 1.000, or the specific gravity of water. The whole scale is founded on the

false premise that pure milk has a precise, uniform specific gravity and that it is possible—as it were—to measure nature with a yard stick. Thus the readings under 100 are supposed to indicate the amount of water added to milk. If, for instance, the reading were 95, it would mean that the milk was 95 per cent. pure and that it was adulterated with 5 per cent. of water.

Since pure milk varies considerably in specific gravity within normal limits the fallacy of this scale is apparent.

It would not receive so much attention here were it not in common use in many of the Eastern states. To convert the readings of the New York Board of Health lactometer into corresponding readings of the Quevenne scale they must be multiplied by 0.29.

QUEVENNE LACTOMETER DEGREES CORRESPONDING TO NEW YORK BOARD OF HEALTH LACTOMETER DEGREES.*

Board of Health Degrees.	Quevenne Scale.	Board of Health Degrees.	Quevenne Scale.	Board of Health Degrees.	Quevenne Scale.	Board of Health Degrees.	Quevenne Scale.
61	17-7	76	22-0	91	26-4	106	30-7
62	18-0	77	22-3	92	26-7	107	31-0
63	18-3	78	22-6	93	27-0	108	31-3
64	18-6	79	22-9	94	27-3	109	31-6
65	18-8	80	23-2	95	27-6	110	31-9
66	19-1	81	23-5	96	27-8	111	32-2
67	19-4	82	23-8	97	28-1	112	32-5
68	19-7	83	24-1	98	28-4	113	32-8
69	20-0	84	24-4	99	28-7	114	33-1
70	20-3	85	24-6	100	29-0	115	33-4
71	20-6	86	24-9	101	29-3	116	33-6
72	20-9	87	25-2	102	29-6	117	33-9
73	21-2	88	25-5	103	29-9	118	34-2
74	21-5	89	25-8	104	30-2	119	34-5
75	21-7	90	26-1	105	30-5	120	34-8

Curd Test.—This is a good rough and ready way to distinguish clean from dirty milk. Liquid rennet is added to warm milk in a milk bottle and when the curd has formed the whey is poured off. After the curd has formed a compact mass in the bottom of the jar it should be cut open. In dirty milk the curd is riddled with holes like a sponge owing to the development of gas caused by the

* Jensen's Milk Hygiene.

growth of certain bacteria. This condition is absent in the curd from clean milk.

Feser's Lactoscope.

This consists of a large, hollow, graduated glass cylinder, into the centre of the base of which is inserted a smaller white glass cylinder marked with horizontal black lines (Fig. 61). The test with the lactoscope depends upon the amount of dilution of milk required in order that the lines on the inner cylinder be seen when diluted milk is placed in the outer cylinder. The richer in fat, the more opaque is the specimen and the greater the dilution required.

Thus 4 c.c. of milk are dropped from a pipette through the aperture in the top of the larger cylinder, and water is added in small amounts and thoroughly mixed with the milk by inverting

Fig. 61.

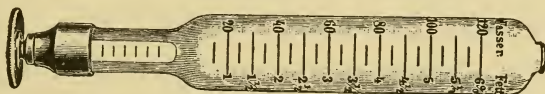

Feser's Lactoscope.

the lactoscope with the finger over the top. When the milk is diluted sufficiently for the black lines on the inner white cylinder to be read, then the percentage of fat corresponds with the figures at the level of the mixture on the larger graduated cylinder (in an upright position).

As has been stated, the lactometer is unreliable when used alone, but, when employed in conjunction with the lactoscope, quite accurate results may be obtained. While milk which has been skimmed and watered may show a normal specific gravity by the lactometer reading, so milk which is exceptionally rich in fat may be only watered so as to still be within the legal requirements as shown by the lactoscope. By the use of both instruments, either skimming or watering, or both skimming and watering, may be detected—unless the milk is still of average richness.

Harrington (Practical Hygiene, p. 111) says: "A normal specific gravity with a low percentage of fat will indicate skimming and watering; low specific gravity with normal or low fat, watering; and high specific gravity and low fat, skimming. Low specific gravity with a high fat will indicate unusual richness; thus cream has a very low specific gravity, due to its preponderance of fat. As a test of the accuracy of this process of examination, the author caused to be analyzed under his supervision 1,714 specimens, which appeared by those tests to be of good quality, and of this number but eight were found to have deviated materially from the statute requirements of 13% of total solids."

In case inspection by lactoscope and lactometer showed a specimen of milk below the legal requirements, this result should be corroborated by the exact methods of the laboratory before it would be wise to institute legal proceedings.

If examination of milk with both lactometer and lactoscope shows that the milk tests within normal limits by both instruments, then the milk cannot be much skimmed and watered, as it is of normal richness. Some considerable experience is needed in the reading of the lactoscope. As a matter of fact, in this city (Seattle) and many others the inspector of milk only collects samples and takes temperatures of milk, the testing being done more accurately in the laboratory.

Selected Forms Used in the Milk Inspection Service of.....*

APPLICATION FOR PERMIT TO SEND OR BRING MILK INTO.....

To the Health Officer,

SIR: In compliance with "An act to regulate the sale of milk in and for other purposes," I hereby make application for a permit to send or bring milk into said from the premises described below, located

Number of shipments per day..... Total number of gallons..... $\left\{ \begin{array}{l} \text{Whole milk} \\ \text{Skim milk} \\ \text{Cream.} \end{array} \right.$

* Forms are those used in the District of Columbia.

Shipped in—Wagon..... Boat..... B. and O. R. R..... B. and P.
 R. R.....
 Time of delivery..... Place of delivery.....
 Consigned to.....

DESCRIPTION OF PREMISES.

BUILDING.

Brick..... Frame.....Stories high

Condition.....

Is any part of it used for any other than dairy purposes?.....

If so, specify, in the space for remarks, what parts of it are so used, and the purposes for which used.

Room for Cattle.

Size..... Long..... Wide.....High

Floor, kind.....

Condition.....

Is it properly sloped and guttered?.....

What disposition is made of the drainage?.....

Ventilation and lighting. How accomplished?.....

Windows. How many?.....

Location.....

Size.....

Are windows glazed?.....

Ventilators. How many?.....

Kind.....

Location.....

Size.....

Doors. How many?.....

Location.....

Stalls. Where located?.....

How many?.....

Size of each?.....wide.....long.....

.....wide.....long.....

Are animals of any kind other than cattle kept in this room?.....

If so, specify how many, and what kind.....

Feeding troughs or boxes. How many?.....

Kind.....

Location.....

Condition.....

Water troughs. How many?.....

Kind.....

Location.....

Condition.....

If water troughs are not used, how are cattle watered?.....

Source of water supply.

If from well, state location.....

Approximate depth.....feet, and construction.....

Location of well with reference to place where dung is deposited. State distance and slope of ground.....

Has water any perceptible odor, color, or taste?.....

If so, describe.....

Receptacles for dung and other refuse. How many?.....

Kind.....

Location.....

Condition.....

Receptacles for milk. How many?.....

Kind.....

Condition.....

What provision is made for cleaning?.....

Is milk cooled immediately after milking?.....

If so, how?.....

BARNYARD.

Size.....long.....wide.....

Is it properly graded?.....and drained?.....

Is it paved?.....

What disposition is made of the drainage?.....

What is its condition as to cleanliness at time of inspection?.....

PASTURE.

Size of.....

Condition of.....

Is it supplied with drinking water for the cattle?.....

If so, from what source?

CATTLE.

How many milch cows are usually kept?.....

How many other cattle, if any, are kept in the same stable?.....

Kind of milch cows used.....

Condition of cows at time of inspection. General condition.....

Cleanliness, etc.....

Character of feed.....

PRIVY ACCOMMODATIONS.

How is human excreta from the premises disposed of?.....

Location of privy, if any?.....

Construction of privy.....

Signature of applicant.....

Post-office address.....

To the Health Officer,

SIR: I have carefully examined the cattle upon the premises above referred to, and their condition is as follows:

.....

Signature.....

Address.....

Personally appeared before me this.....day of....., 190., the subscriber, who being duly sworn deposes and says that he is a veterinary surgeon, practicing in accordance with the laws of the State in which he resides, and that he has personally examined the cattle referred to in the above statement and knows them to be the same as are referred to in the application to which the certificate is appended, and that their condition is correctly described without evasion or concealment.

Signature.....

Address.....

HEALTH DEPARTMENT,

No.....

DAIRY PERMIT.

Permission is hereby granted..... to maintain a dairy at..... subject to regulations governing dairies within

....., M. D.,
Health Officer.

....., 190..

Issued in accordance with an "Act to regulate the sale of milk in and for other purposes," approved

This permit is not transferable, and applies only to the premises specified hereon. If location is changed, new permit is required.

HEALTH DEPARTMENT,

No.....

DAIRY FARM PERMIT.

Permission is hereby granted..... to maintain a dairy farm at..... subject to regulations governing dairy farms within

....., M. D.,
Health Officer.

....., 190..

Issued in accordance with an "Act to regulate the sale of milk within and for other purposes," approved

This permit is not transferable.

HEALTH DEPARTMENT,

No.....

MILK IMPORTER'S PERMIT.

Permission is hereby granted to bring or send milk into from the dairy farm located at and described in application No. subject to the following conditions:

That none but pure and unadulterated milk shall be, with knowledge of its impurity, brought into said

That in the management of the dairy farm upon which the milk is produced, or at the dairy at which the milk is collected and stored prior to shipment, the applicant shall be governed by the regulations of the health office of, approved by the Commissioners of said, issued for dairies and dairy farms in said, when said regulations do not conflict with the law of the State in which said dairy or dairy farm is located.

That said dairy or dairy farm may be inspected at any time without notice by the health officer of, or his duly appointed representative.

....., M. D.,
Health Officer.

....., 190..

Issued in accordance with an "Act to regulate the sale of milk in and for other purposes," approved

This permit is not transferable.

CLEAN MILK

Notice of violation of dairy regulations.

Any objection to this notice should be filed with the health officer before the expiration of the time allowed for making the changes specified.

No. HEALTH DEPARTMENT,
DAIRY AND DAIRY FARM INSPECTION, 190..

Mr.

Sir: Your attention is called to the following violations of the Regulations for the Government of Dairies and Dairy Farms, which have been found to exist upon your premises:

.....

You are hereby notified to correct the same within days from the date of service of this notice.

By order of the health officer:

.....
Inspector of Dairies and Dairy Farms.

Cancellation of permit—preliminary inspector's notice.

HEALTH DEPARTMENT OF
DAIRY AND DAIRY FARM INSPECTION, 190..

Mr.

Sir: An inspection of your dairy farm this date shows that you are violating the conditions under which your permit No. was issued, namely

You are therefore directed to show cause in writing to the health officer on or before, 190., why your permit should not be cancelled.

By order of health officer:

.....
Inspector.

Cancellation of permit—preliminary health officer's letter.

..... 190..

Mr.

Sir: I have the honor to inform you that the report of Inspector of this department, dated 190., shows that you are violating the conditions under which your permit No. to bring or send milk into was issued; namely In view of this fact, you are hereby directed to show cause on or before why your permit should not be revoked.

Respectfully,

..... M. D.,
Health Officer.

MILK INSPECTION

SANITARY INSPECTION OF DAIRIES.

Owner or lessee of farm.....
 Town..... State.....
 Total No. of cows..... No. milking..... Quarts of milk produced daily.....
 Is product sold at wholesale or retail?.....
 If shipped to dealer give name and address.....
 Permit No..... Date of inspection....., 190
 Score.

	Score.		Remarks.
	Perfect.	Allowed.	
<i>Cows.</i>			
Condition (2).....	} 10
Health (8).....	
Cleanliness.....		5
Water supply.....	5—20
<i>Stables.</i>			
Construction.....	5
Cleanliness.....
Light.....	5
Ventilation (4).....	} 7
Cubic space per cow (3).....	
Removal of manure (2).....	
Stable yard (1).....	3—25
<i>Milk house.</i>			
Construction (2).....	} 5
Equipment (3).....	
Cleanliness.....	5
Care and cleanliness of utensils.....	5
Water supply (Temp. °F.).....	5—20
<i>Milkers and milking.</i>			
Health of attendants.....	5
Cleanliness of milking.....	10—15
<i>Handling the milk.</i>			
Prompt and efficient cooling.....	} 10
(Temperature of milk. °F.).....	
Storing at a low temperature.....	5
Protection during transportation.....	5—20
Total score.....	100

Sanitary conditions are—Excellent..... Good..... Fair..... Poor.....
 Suggestions by inspector.....
 Signed.....
Inspector.

SANITARY INSPECTION OF DAIRIES (REVERSE SIDE).

DIRECTIONS FOR SCORING.

COWS.	Perfect score.
<i>Condition and healthfulness.</i> —Deduct 2 points if in poor flesh, and 8 points if not tuberculin-tested.....	10
<i>Cleanliness.</i> —Clean, 5; good, 4; fair, 2; bad, 0.....	5
<i>Water supply.</i> —If clean and unpolluted, 5; fair, 3; otherwise, 0.....	5

STABLES.

<i>Construction.</i> —For cement floor (a)* in good condition allow 2 points; fair, 1; poor, 0; wood floor (b) or other material in good condition, 1; fair, ½; poor, 0; good tie (c), 1; good manger (d), 1; box stall (e), 1..	5
<i>Cleanliness.</i> —If thoroughly clean, including floor (a), windows (b), and ceilings (c), 5; good, 4; medium, 3; fair, 2; poor, 1; bad, 0.....	5
<i>Light.</i> —Four square feet of glass per cow, 5; 1 point off for each 20 per cent less than 4 square feet per cow.....	5
<i>Ventilation.</i> —Good ventilating system, 4; fair, 3; poor, 2; bad, 0.....	4
<i>Cubic space per cow.</i> —If 500 cubic feet or over per cow, 3; less than 500 and over 400, 2; less than 400 and over 300, 1; less than 300, 0.....	3
<i>Removal of manure.</i> —Hauled to field daily, 2; removed at least 30 feet from stable, 1; otherwise, 0.....	2
<i>Stable yard.</i> —In good condition (a), ½; well drained (b), ½; otherwise, 0.	1

MILK HOUSE.

<i>Construction.</i> —Tight, sound floor, and not connected with any other building (a), well lighted (b), well ventilated (c), 2; (d) if connected with another building under good conditions, 1; otherwise, 0; (e) if no milk house, 0	2
<i>Equipment.</i> —Hot water for cleaning utensils (a), 1; cooler (b), 1; proper pails (c) and strainers (d) used for no other purposes, 1.....	3
<i>Cleanliness.</i> —Interior clean, 5; good condition, 4; medium, 3; fair, 2; poor, 1; bad, 0.....	5
<i>Care and cleanliness of utensils.</i> —Clean (a) 3; kept in milk house or suitable outside rack (b), 2; otherwise, 0.....	5
<i>Water supply.</i> —If pure and clean running water, 5; pure and clean still water, 3; otherwise, 0.....	5

MILKING.

<i>Attendants.</i> —Healthy.....	5
<i>Cleanliness of milking.</i> —Clean milking suits, milking with clean dry hands, and attention to cleanliness of udder and teats while milking, 10; no special suits, but otherwise clean (a), 7; deduct 4 points for uncleanly teats (b) and udder (c) and 3 points for uncleanly hands (d).....	10

* The letters a, b, c, etc., should be entered on score card to show condition of dairy, and when so entered should always indicate a deficiency.

HANDLING THE MILK

Perfect score.

<i>Prompt and efficient cooling.</i> —If prompt (a), 5; efficient (b), if 50° F. or under, 5; over 50° and not over 55°, 4; over 55° and not over 60°, 3; over 60°, 0; if neither prompt nor efficient, 0.....	10
<i>Storing at low temperature.</i> —If 50° F. or under, 5; over 50° and not over 55°, 4; over 55° and not over 60°, 3; over 60°, 0.....	5
<i>Protection during transportation to market.</i> —If thoroughly protected (iced), 5; good protection, 4; partly protected 2; otherwise, 0.....	5

SCORE.

100

If total score is 90 or above and each division 85% perfect or over, the dairy is Excellent (entitled to registry).

If total score is 80 or above and each division 75% perfect or over, the dairy is Good.

If total score is 70 or above and each division 65% perfect or over, the dairy is Fair.

If total score is below 70 and any division is below 65% perfect, the dairy is Poor.

[United States Department of Agriculture, Bureau of Animal Industry, Dairy Division.]

Sanitary inspection of city milk plants.

Owner or manager.....	Trade name.....
City.....	Street and No..... State.....
Number of wagons.....	Gallons sold daily { Milk..... Cream.....
Permit or license No.....	Date of inspection..... 190

	Score.		Remarks.
	Perfect.	Allowed.	
<i>Milk room.</i>			
Location.....	10		
Construction—	} 10		
Floor (3).....			
Walls and ceiling (3).. Drainage (4).....			
Cleanliness.....	15		
Light and ventilation.....	10		
Equipment—	} 15		
Arrangement (3).....			
Construction—			
Sanitary (2)..... Durability (2).....			
Condition (3).....			
Cleanliness (5).....			

	Score.		Remarks.
	Perfect.	Allowed.	
<i>Milk.</i>			
Handling (12).....	} 20
Storage (8).....	
<i>Sales room.</i>			
Location (2).....	} 10
Construction (2).....	
Equipment (2).....	
Cleanliness (4).....	
<i>Wagons.</i>			
General appearance (2)....	} 10
Protection of product (3)..	
Cleanliness (5).....	
Total.....	100	

Sanitary inspection of city milk plants (reverse side).

DIRECTIONS FOR SCORING.

MILK ROOM.

Location.—If not connected by door with any other building, and surroundings are good, 10; when connected with other rooms, such as kitchens, stables, etc., make deductions according to conditions.

Construction.—If good cement floor, and tight, smooth walls and ceiling, and good drainage, allow 10; deduct for cracked or decayed floors, imperfect wall and ceiling, etc.

Cleanliness.—If perfectly clean throughout, allow 15; deduct for bad odors, unclean floor and walls, cobwebs, unnecessary articles stored in room, etc.

Light and ventilation.—If window space is equivalent to 15% or more of the floor space, allow 5; deduct 1 point for every 3% less than the above amount.

Equipment:

Arrangement.—Allow 3 points for good arrangement; if some of the equipment is out of doors or so placed that it can not be readily cleaned, make deductions according to circumstances.

Condition.—If in good repair, allow 4 points; make deductions for rusty, worn-out, or damaged apparatus.

Construction—

Sanitary: If seams are smooth, and all parts can be readily cleaned, allow 2. Deduct for poor construction, from sanitary standpoint.

Equipment:

Durability: If made strong and of good material, allow 2. Deduct for light construction and poor material.

Cleanliness.—If perfectly clean, allow 8 points; make deductions according to amount of apparatus improperly cleaned.

MILK.

Handling.—If milk is promptly cooled to 50° F. or lower, allow 12 points; or if pasteurized at a temperature of 149° F. or above and promptly cooled to 50° or lower, allow 12 points. Deduct 1 point for every 2° above 50°. If milk is pasteurized imperfectly, deduct 6 points. If milk is improperly bottled or otherwise poorly handled, make deductions accordingly.

Storage.—If stored at a temperature of 45° F. or below, allow 8 points. Deduct 1 point for every 2° above 45°.

SALES ROOM.

Location.—If exterior surroundings are good and building is not connected with any other undesirable conditions, allow 2; for fair conditions, allow 1; poor conditions, 0.

Construction.—If constructed of material that can be kept clean and sanitary, allow 2; for fair construction, allow 1; poor construction, 0.

Equipment.—If well equipped with everything necessary for the trade, allow 2; fair equipment, 1; poor equipment, 0.

Cleanliness.—If perfectly clean allow 4 points; if conditions are good, 2; fair, 1; poor, 0.

WAGONS.

General appearance.—If painted and in good repair, allow 2 points; for fair condition, 1; poor, 0.

Protection of product.—If product is iced, allow 3 points; well protected but not iced, 1; no protection, 0.

Cleanliness.—If perfectly clean, allow 5; good, 3; fair, 2; poor, 0.

Collection of samples—Inspector's memorandum and label.*

HEALTH DEPARTMENT OF.....

HEALTH DEPARTMENT OF.....

No. 190..
 Milk }
 Cream }Pt
 Name of vendor.....
 Address.....
 Business.....
 Taken from.....
 Served by.....
 No. card. Amount.....
 Inspector.....

Specimen No.....
 Purchased as.....
 Time of purchase.....
 Inspector.....

HEALTH DEPARTMENT OF.....

....., 190..

REPORT OF ANALYSIS.

Substances offered for sale or sold as
 Milk..... Cream..... Skimmed milk.....
 by.....
 at..... on.....

Analysis.

	1	2	3	4	5	6	7	8	9	10
	Per cent.	Per cent.	Per cent.	Per cent.	Per cent.	Per cent.	Per cent.	Per cent.	Per cent.	Per cent.
Fat.....										
Solids not fat.....										
* Water.....										
* Odor.....										
* Acidity.....										
* Added coloring matter....										
* Preservatives.....										

Remarks.....

.....Analyst.

* Form used in District of Columbia.

Legal standards: Milk.—Not less than $3\frac{1}{2}$ per cent. fat, 9 per cent. solids not fat, and not more than $87\frac{1}{2}$ per cent. water.

Cream.—Not less than 20 per cent. fat.

Skimmed Milk.—Not less than 9.3 per cent. solids, including fats.

Wholesome milk must come from healthy cows living under proper sanitary conditions. It must have been properly cared for at the time of milking and continually thereafter; especially must it have been kept cold. This report shows the chemical composition of the milk analyzed, but indicates only in an imperfect manner its wholesomeness, which can be determined only by considering the condition of the cows, dairy farm, and dairy in connection with this analysis.

There is as yet no fixed standard for acidity in milk, but any sample of milk or cream found to be, in the judgment of the health department, too acid will be regarded as unwholesome, and the seller prosecuted.

For the production of pasteurized milk on a large scale perhaps the following is thus far the most notable attempt to embody in serviceable rules our scientific knowledge of the effects of heating milk.

* The following rules shall regulate the pasteurizing of milk and milk products offered for sale, exposed for sale, or kept with the intention of selling within the city of Chicago, after January 1st A. D. 1909:

Rule 1. Milk and skimmed milk. Milk and skimmed milk shall not contain more than 100,000 bacteria per cubic centimeter from May 1st to September 30th, and not over 50,000 bacteria per cubic centimeter between October 1st and April 30th.

Rule 2. Cream and ice cream. Cream and ice cream shall not contain more than 200,000 bacteria per cubic centimeter from May 1st to September 30th, and not over 100,000 bacteria per cubic centimeter between October 1st and April 30th.

Rule 3. Milk, skimmed milk, buttermilk, cream and ice cream. An original package of pasteurized milk, skimmed milk, buttermilk, cream or ice cream, exposed to the temperature of the room for 48 hours and stoppered with a sterile cotton plug, shall not show evidences of putrefaction, after being so exposed.

Rule 4. Skimmed milk and ice cream. Skimmed milk and ice cream shall give a negative test when treated in the following manner:

* From Hoard's Dairyman, Dec. 4, 1908.

To 5 c.c. of the pasteurized product add 2 drops of a 2 per cent. solution of paraphenylenediamin, and 1 drop of a 2 per cent. solution of hydrogen peroxide, and agitate.

Not more than a tinge of blue shall be obtained by this test within 30 seconds after mixing.

Rule 5. Butter. Butter shall respond to the following test:

Twenty-five grams of pasteurized butter placed in a small beaker and heated by being placed in water at 60 degrees centigrade, the clear butter fat then poured off and the remaining liquid then diluted with an equal volume of water. The mixture thus obtained is now treated with 2 drops of a 2 per cent. solution of paraphenylenediamin and one drop of a solution of 2 per cent. hydrogen peroxide.

When thus treated not more than a perceptible blue color shall be obtained within 30 seconds after mixing.

Rule 6. Pasteurizing temperatures. All pasteurized milk, cream, skimmed milk, milk products, and milk and cream used in the production of milk products shall be pasteurized in accordance with the following regulations:

(a) Continuous pasteurization—In all continuous pasteurization the milk and cream shall be heated to a temperature which shall be determined and fixed by the department of health for each machine at a point corresponding to the temperature required to kill 99 per cent. of the bacteria and all pathogenic bacteria contained in the raw product. For this determination, ordinary raw milk containing in the neighborhood of 3,000,000 bacteria shall be used and the pasteurized product shall be collected as it flows from the cooling apparatus.

All continuous pasteurizers shall be equipped with a feeding pipe which is so constructed that the pasteurizer cannot be fed in excess of its normal working capacity; that is, in excess of the working capacity of the machine at which 99 per cent. of the bacteria are killed when the required amount of heat is applied.

All continuous pasteurizers operated outside the city limits, for the production of pasteurized milk and milk products to be sold at the city of Chicago, shall be equipped with an apparatus regulating auto-

matically the supply of steam and heat, so as to correspond with and produce the required temperature of the outflow of the pasteurized product. These automatic thermo regulators should be accurate and must be approved by the commissioner of health before being installed.

A recording apparatus shall be installed upon all continuous pasteurizers operated within the city limits so as to record during operation the temperature of the pasteurized product as it flows from the heater. The thermometer of this recording apparatus must be accurate and kept immersed in the milk in such a way that it is not exposed to escaping steam or other heat except the heated milk.

The records made by this recording thermometer must be accurate and made in a chamber which is kept under lock and key in the control of the department of health.

The automatic thermo regulating and recording apparatus may be combined into one instrument and it is recommended that all pasteurizers be equipped with both appliances or the combination apparatus.

(B) Held pasteurization. Whenever milk is held during pasteurization in such a manner that the process of pasteurizing is not a continuous one, namely; a continuous flow of milk through the heating or heat retaining chamber, the process shall be designated as "Held Pasteurization." Such methods of pasteurization and pasteurization appliances or systems installed and used shall be examined and approved by the commissioner of health, or his duly appointed representatives, when all of the following requirements are fulfilled:

1. When the pasteurized product shows that over 99 per cent. of the bacteria and all pathogenic bacteria contained in the raw product have been destroyed.

2. When the mechanism of the pasteurizer or pasteurizing system is such that the three important elements, namely: the temperature, time of exposure, and the quantity of milk exposed at one time, can be readily kept under control and observation by the department of health.

3. When the following conditions are complied with:

A uniform heating of 140 degrees F. maintained for twenty minutes; 150 degrees F. maintained for 15 minutes; 155 degrees F. main-

tained for 5 minutes; 160 degrees F. maintained for 1½ minutes; 165 degrees F. maintained for one minute.

The time shall be calculated from the period that the entire quantity reaches the required temperature.

Rule 7. Cooling temperatures. The pasteurized product shall be cooled at once to a temperature of 45 degrees F. or less. This cooling shall be so conducted that the pasteurized product is not exposed to the air or other contamination. This cooling apparatus shall be so constructed that it can be readily cleaned and sterilized.

CIRCULARS.

1st.—“Certified Milk.”

CIRCULAR OF INFORMATION CONCERNING THE REQUIREMENTS OF THE MILK COMMISSION OF THE MEDICAL SOCIETY OF THE COUNTY OF NEW YORK FOR “CERTIFIED” MILK.

The Commission appointed by the Medical Society of the County of New York to aid in improving the milk supply of New York City invites the co-operation of the milk dealers and farmers in attaining that end. The sale of pure milk is of advantage to those furnishing it, as well as to those who use it. The Commission has undertaken to assist both consumer and producer by fixing a standard of cleanliness and quality to which it can certify, and by giving information concerning the measures needful for obtaining that degree of purity.

The most practicable standard for the estimation of cleanliness in the handling and care of milk is its relative freedom from bacteria. The Commission has tentatively fixed upon a maximum of 30,000 germs of all kinds per cubic centimeter of milk, which must not be exceeded in order to obtain the indorsement of the Commission. This standard must be attained solely by measures directed toward scrupulous cleanliness, proper cooling, and prompt delivery. The milk certified by the Commission must contain not less than four per cent. of butter fat, on

the average, and have all other characteristics of pure, wholesome milk.

In order that dealers who incur the expense and take the precautions necessary to furnish a truly clean and wholesome milk may have some suitable means of bringing these facts before the public, the Commission offers them the right to use caps on their milk jars stamped with the words, "Certified by the Commission of the Medical Society of the County of New York." The dealers are given the right to use these certificates when their milk is obtained under the conditions required by the Commission and conforms to its standards.

The required conditions are as follows :

I.—THE BARNYARD.

The barnyard should be free from manure and well drained, so that it may not harbor stagnant water. The manure which collects each day should not be piled close to the barn, but should be taken several hundred feet away. If these rules are observed not only will the barnyard be free from objectionable smell, which is always an injury to the milk, but the number of flies in summer will be considerably diminished. These flies in themselves are an element of danger, for they are fond of both filth and milk, and are liable to get into the milk after having soiled their bodies and legs in recently visited filth, thus carrying it into the milk. Flies also irritate cows, and by making them nervous reduce the amount of their milk.

2.—THE STABLE.

In the stable the principles of cleanliness must be strictly observed. The room in which the cows are milked should have no storage loft above it ; where this is not feasible, the floor of the loft should be tight, to prevent the sifting of dust into the stable beneath. The stables should be well ventilated, lighted, and drained, and should have tight floors, preferably of cement. They should be whitewashed inside at least twice a year, and the air should always be fresh and without bad odor. A sufficient number of lanterns should be provided to enable the

necessary work to be properly done during dark hours. There should be an adequate water supply and the necessary wash-basins, soap and towels. The manure should be removed from the stalls twice daily, except when the cows are outside in the fields the entire time between the morning and afternoon milkings. The manure gutter must be kept in a sanitary condition, and all sweeping and cleaning must be finished at least twenty minutes before milking, so that at that time the air may be free from dust. There should be an adequate supply of water, warm and cold, and the necessary wash-basins, soap and towels.

3.—WATER SUPPLY.

The whole premises used for dairy purposes, as well as the barn, must have a supply of water absolutely free from any danger of pollution with animal matter, and sufficiently abundant for all purposes and easy of access.

4.—THE COWS.

No cows will be allowed in the herd furnishing certified milk except those which have sufficiently passed a tuberculin test. All must be tested at least once a year by a veterinarian approved by the milk commission. Any animal suspected of being in bad health must be promptly removed from the herd and her milk tested. Do not allow the cows to be excited by hard driving, abuse, loud talking, or any unnecessary disturbance.

Cleaning.—Groom the entire body of the cow daily. Before each milking wash the udder with a cloth used only for the udders and wipe it with a clean dry towel. Never leave the udder wet and be sure that the water and towel used are clean. The tail should be kept clean by frequent washing. If the hair on the flanks, tail and udder is clipped close, and the brush on the tail is cut short, it will be much easier to keep the cow clean. The cows must be kept standing after the cleaning until the milking is finished. This may be done by a chain or a rope under the neck.

Feed.—Do not allow any strongly-flavored food, like garlic, to be eaten by the cows.

When ensilage is fed, it must be given in only one feeding daily, and that after the morning milking, and the full ration shall consist of not more than 20 pounds daily for the average-sized cow. When fed in the fall small amounts must be given and the increase to the full ration must be gradual.

Cornstalks must not be fed until after the corn has blossomed, and the first feedings must be in small amounts and the increase must be gradual. If fed otherwise, ensilage and cornstalks are liable to cause the milk to affect children seriously.

5.—THE MILKERS.

The milker should be personally clean. He should neither have nor come in contact with any contagious disease while employed in milking or handling milk. In case of any illness in the person or family of any employee in the dairy, such employee must absent himself from the dairy until a physician certifies that it is safe for him to return.

Before milking, the hands should be thoroughly washed in warm water with soap and a nail brush and well dried with a clean towel. On no account should the hands be wet during the milking.

In order that the milk commission may be informed as to the health of the employees at the certified farms, the commission has had postal cards printed, to be supplied to the farms, and to be filled out and returned each week, by the owner, manager, or physician of the farm, certifying that none are handling the milk who are in contact with any contagious disease.

The milkers should have light-colored, washable suits, including caps, and not less than 2 clean suits weekly. The garments should be kept in a clean place, protected from dust, when not in use.

Iron milking stools are recommended and they should be kept clean.

Milkers should do their work quietly and at the same hour morning and evening. Jerking the teat increases materially the bacterial contamination of the milk and should be forbidden.

6.—HELPERS OTHER THAN MILKERS.

All persons engaged in the stable and dairy should be reliable and intelligent. Children under twelve years should not be allowed in the stable during milking, since in their ignorance they may do harm, and from their liability to contagious diseases they are more apt than older persons to transmit them through the milk.

7.—SMALL ANIMALS.

Cats and dogs must be excluded from the stables during the time of milking.

8.—THE MILK.

All milk from cows sixty days before and ten days after calving must be rejected. The first few streams from each teat should be discarded, in order to free the milk ducts from milk that has remained in them for some time and in which bacteria are sure to have multiplied greatly. If in any milking a part of the milk is bloody or stringy or unnatural in appearance, the whole quantity of milk yielded by that animal must be rejected. If any accident occurs in which a pail becomes dirty, or the milk in a pail becomes dirty, do not try to remove the dirt by straining, but put aside the pail, and do not use the milk for bottling, and use a clean pail.

Remove the milk of each cow from the stable immediately after it is obtained to a clean room and strain through a sterilized strainer of cheesecloth and absorbent cotton.

The rapid cooling is a matter of great importance. The milk should be cooled to 45° F. within an hour and not allowed to rise above that as long as it is in the hands of producer or dealer. In order to assist in the rapid cooling, the bottles should be cold before the milk is put into them.

Aeration of milk beyond that obtained in milking is unnecessary.

9.—UTENSILS.

All utensils should be as simple in construction as possible and so made that they may be thoroughly sterilized before each using.

Coolers, if used, should be sterilized in a closed sterilizer, unless a very high temperature can be obtained by the steam sent through them.

Bottling machines should be made entirely of metal with no rubber about them, and should be sterilized in the closed sterilizer before each milking, or bottling.

If cans are used, all should have smoothly soldered joints, with no places to collect the dirt.

Pails should have openings not exceeding 8 inches in diameter, and may be either straight pails, or the usual shape with the top protected by a hood.

Bottles should be of the kind known as "common sense," and capped with a sterilized paraffined paper disk, and the caps authorized by the commission.

All dairy utensils, including the bottles, must be thoroughly cleansed and sterilized. This can be done by first thoroughly rinsing in warm water, then washing with a brush and soap or other alkaline cleansing material and hot water and thoroughly rinsing. After this cleansing they should be sterilized by boiling, or in a closed sterilizer with steam, and then kept inverted in a place free from dust.

10.—THE DAIRY.

The room or rooms where the utensils are washed and sterilized and milk bottled should be at a distance from the house, so as to lessen the danger of transmitting through the milk any disease which may occur in the house.

The bottling room, where the milk is exposed, should be so situated that the doors may be entirely closed during the boiling and not opened to admit the milk nor to take out the filled bottles.

The empty cases should not be allowed to enter the bottling room nor should the washing of any utensils be allowed in the room.

The workers in the dairy should wear white washable suits, including cap, when handling the milk.

Bottles must be capped, as soon as possible after filling, with the sterilized disks.

II.—EXAMINATION OF THE MILK AND DAIRY INSPECTION.

In order that the dealers and the Commission may be kept informed of the character of the milk, specimens taken at random from the day's supply must be sent weekly to the Research Laboratory of the Health Department, where examinations will be made by experts for the Commission; the Health Department having given the use of its laboratories for this purpose.

The Commission reserves to itself the right to make inspections of certified farms at any time and to take specimens of milk for examination. It also reserves the right to change its standards in any reasonable manner upon due notice being given to the dealers.

After January 1, 1902, the expenses incurred in making the regular milk examinations and inspections will be borne by the dealers. In fixing the charges each farm or group of farms will be considered a unit. The Secretary of the County Medical Society will send the bills to the dealers about the middle of each month. Prompt payment is requested.

The monthly charges, which are intended to cover all expenses, will be as follows:

For each group of farms sending daily less than 100 quarts	\$8.00
“ “ “ 100 to 200 “	10.00
“ “ “ 200 to 500 “	12.00
“ “ “ over 500 “	15.00

2d.—“Inspected Milk.”

CIRCULAR OF INFORMATION CONCERNING THE REQUIREMENTS OF THE MILK COMMISSION OF THE MEDICAL SOCIETY OF THE COUNTY OF NEW YORK FOR “INSPECTED” MILK.

The Commission appointed by the Medical Society of the County of New York to aid in improving the milk supply of New York City has formulated the following requirements, affecting the farms inspected by it and the handling of the milk obtained at these farms.

The Commission offers those dealers complying with these requirements the right to use caps on their milk bottles, stamped: "Inspected. Milk Commission Medical Society, County of New York."

The requirements are as follows:

I. THE BARNYARD.

- (a) It must contain no manure in summer and none in contact with the stable in winter.
- (b) It must be well drained and kept reasonably clean.

2. THE STABLES.

- (a) The ventilation and light must be sufficient for the number of cows stabled, so that the barn shall be light and the air never close.
- (b) The floor shall be wood or cement.
- (c) The ceiling shall be tight, if a loft above is used.
- (d) Basins, hand brushes, clean water, soap and clean towels shall be provided in the barn or adjacent dairy room.
- (e) The stable shall be whitewashed in the fall, and in the spring if necessary.
- (f) A sufficient number of lanterns shall be provided to allow the milking to be carried on properly.
- (g) Clean the ceilings and sidings once a month.
- (h) The bedding shall be shavings, sawdust, dried leaves, cut straw, or other material that meets the approval of the Commission.
- (i) The soiled bedding must be removed daily.
- (j) The manure must be removed from the stalls and open manure-gutter. If a covered manure-gutter is used, it must be kept in a sanitary condition.
- (k) The application of land-plaster or lime on the floor daily is recommended.
- (l) Sweep the entire floor outside the stalls daily at least an hour before milking is begun.

3. WATER SUPPLY.

Pure water must be used for all purposes. It must be accessible and abundant.

4. THE COWS.

- (a) Discard milk containing mucus or blood and that from any diseased cow.
- (b) Reject milk from any animal forty-five days before and six days after calving.
- (c) The food given must be suitable both in amount and kind and must not give a disagreeable flavor to the milk.
- (d) Keep the cows clean on flanks, belly, udder and tail.
- (e) Clip long hairs about udders and clip the tail sufficiently to clear the ground.
- (f) The cows must be kept from lying down between the cleaning and milking. The best means of accomplishing this is by throatlatches.
- (g) Clean the udder thoroughly before milking.

5. THE MILKERS.

- (a) No milker or assistant shall have any connection with the milk at any stage of its production if he has any communicable disease, or if he has been exposed to scarlet fever, diphtheria, typhoid fever, or small-pox.
- (b) After having everything prepared for milking, thoroughly wash the hands with soap, water, and brush, so that they may be clean when milking is begun.
- (c) The hands and teats must be kept dry during milking. If they become moistened with milk, they must be wiped dry with a clean towel.
- (d) Suitable clean outer garments, such as overalls and jumpers, must be put on before milking.

6. UTENSILS.

- (a) Strainers, whether metal, gauze, or cotton, must be absolutely clean when used for straining milk.
- (b) All dairy utensils must be absolutely clean and free from dust.

THE MILK.

1. The milk must not be adulterated in any way.
2. It must average 3.6 per cent. of butterfat.
3. Cooling must begin at once. The temperature of the milk must be reduced to 50° F. within two hours and kept below that temperature until delivered to the consumer.
4. When delivered to the consumer the milk must not average over 100,000 bacteria per cubic centimeter from May 1st to September 30th, and not over 60,000 bacteria per cubic centimeter from October 1st to April 30th. If the Commission's requirements are fulfilled, the bacteria will not be in excess of the number permitted.

INSPECTIONS.

1. The farms which furnish inspected milk must always be open to inspection by the Commission.
2. Samples of milk must be regularly submitted for bacteriological examination once a month.

WORKING METHODS AND STANDARDS.*

While the aims and general requirements of the different commissions are similar, there has been considerable diversity in respect to details, most of them, however, of a nonessential character.

The original plan outlined the fundamental requirements, and it remained for each commission to develop working methods and standards suitable to its particular locality.

In any case the commission agrees to certify to milk conforming to its standards when produced in well-equipped dairies conducted in accordance with prescribed sanitary requirements.

In order that these facts may be determined, a veterinary surgeon, a bacteriologist, and a chemist are selected by the commission.

When a dairyman signifies his willingness to co-operate in the production of pure milk, the veterinary surgeon visits the farm and in-

* From Bull. 41. Hygienic Laboratory, 1908, U. S. Treasury Dep't.

pects the buildings, their location, and sanitary condition. He also observes the hygienic methods employed in the production and handling of the milk, and physically examines the cows in the herd.

If it is financially possible a physician should visit a farm supplying certified milk at weekly intervals. Postal cards should be supplied the farm superintendent, on which he should report the existence of any illness (including sore throat) on the premises. The physician should inspect to determine the presence of any illness among the employees or their families and especially as to the existence of scarlatina, diphtheria, typhoid fever, consumption and skin diseases. The general hygienic condition of the employees, premises and quality of the water supply should be reported. The precise number of employees must be ascertained and cases of recent illnesses investigated.

Veterinary inspection should be made with particular reference to bovine infections which may be communicated to man in milk. 1. Such general infections of cattle include—tuberculosis, cowpox, tetanus, anthrax, foot and mouth disease, black quarter, rabies, trembles, contagious pleuro-pneumonia and actinomycosis. It is somewhat doubtful whether the latter can be conveyed to man by milk. 2. Infections of the digestive tract in which germs in the feces are likely to contaminate milk. These include enteritis, dysentery and calf cholera. Milk from cows suffering from digestive disturbances is unfit for use, since it may contain deleterious chemical bodies. 3. Mastitis of various sources, as that due to tubercle and colon bacilli, streptococci and staphylococci, *B. necrophorus* and actinomycosis. 4. Local infections elsewhere, as septic metritis, abscesses, suppurating wounds and necrosis. 5. Any acute disease in which toxins and perhaps micro-organisms may escape in the milk.

In a general way it may then be said that bacteriological examinations of certified milk should be made weekly, chemical examinations and veterinary inspections monthly, and medical inspections weekly or as circumstances may require.

This examination also includes the application of the tuberculin test. These inspections are subsequently made at frequent intervals and reports are made to the commission, the following being a convenient form in use at Cleveland and other places:

Inspector's report. Dairy of Date

Herd: Milking cows Dry cows Hospital cows

Cows recently calved Cows added since last report

Not yet tuberculin tested Quarantined

Stable: Cleanliness Ventilation Temperature

Dairy building: Cleanliness Ventilation Temperature

Other buildings

Utensils

Care and cleanliness in milking

Food

Health of employees

Remarks

Based upon the foregoing inspection made at the request of The Milk Commission of the city of Cleveland, I beg to report that this dairy conforms to the requirements of said commission and recommend that its milk be submitted to the bacteriologist and chemist for their examinations.

(Signed) ———, Veterinarian.

The chemist and bacteriologist each examine from time to time at the discretion of the commission, samples of the milk taken at random or purchased on the open market.

The former determines the specific gravity, acidity, percentage of fats, sugar, proteids, water and mineral matter present, and the presence or absence of preservatives and chemical adulteration. The latter determines the number, and so far as practicable, the character of bacteria and the presence or absence of pus cells.

The following forms are convenient for rendering the reports of these examinations:

No Dairy Date

Distributor Collected by

Sealing Date of milking

Hour collected Temperature when collected °F.

General condition: Color Odor Taste

Separation of cream Macroscopic sediment

Chemical composition: Specific gravity Acidity Total%

Fat %. Sugar %. Proteids %.

Salts %. Ash %.

Preservatives Coloring matters Adulterants

Remarks

The examination recorded above, made at the request of The Milk Commission of the city of Cleveland, shows a { milk } reaching the chemical standard adopted by the commission.

(Signed) ———, Chemist.

[The foregoing card is printed on pink paper.]

No. Dairy Date
 Distributer Collected by
 Sealing Date of milking
 Hour collected Cultures made Temperature when examined
°F.
 General condition: Color Odor Taste ,
 Separation of cream Macroscopic sediment
 Bacteriological examination: Media
 Temperature Dilution
 Bacteria per c. c. Average
 Pathogenic bacteria
 Microscopic examination, blood, pus, tubercle bacilli, etc.

The examination recorded above, made at the request of The Milk Commission of the city of Cleveland, shows a { milk } reaching the chemical standard
 { cream }
 standard adopted by the commission.

(Signed) ———, Bacteriologist.

[The foregoing card is printed on light blue paper.]

It is generally believed that the bacteriological examination should be repeated once a week, the chemical examination once a month, and the veterinary inspection once a month—the tuberculin test to be used on every new cow added to the herd and reapplied at least once or twice a year.

Inquiry is also made, usually by a member of the commission, regarding the health of employees, and in addition, the dairyman is in certain instances required to render a regular report regarding the presence or absence of communicable diseases among the dairy *personnel*. The following form is used at Cleveland, Ohio, for this purpose:

For the information of The Milk Commission, I hereby answer the following questions for the week ending, 19 ..

- I. Are any of the men handling milk at your farm ill with any communicable disease?
- II. Is there any communicable disease in the families with which they are connected?
- III. Have any been in contact with any communicable disease and then excluded from the milking place?
- IV. Shipments of certified milk and cream in past week:
 (a) Quarts of certified milk (b) Pints of certified cream
 (c) Bottles of certified milk (d) Bottles of certified cream
- V. How many unbroken boxes of caps have you?

(Signed)

Upon these reports the commission bases its action in respect to certification and the certificates are renewed once a month.

The dairyman is thus authorized to indicate such indorsement, either by using on his bottle a cap bearing the name of the Medical Milk Commission and the term "certified milk" or a copy of the certificate.

In New York the law forbids the use of the term "certified" on the cap unless accompanied by the name of the society which certifies it, and in some other places the certificates bear a copyrighted monogram to prevent their fraudulent use.

For examples of these methods of designating such milk, see Fig. 51, p. 169.

When the certificate form is used it is placed between the cap and a parchment covering the neck of the bottle, and in either case the date of milking must appear, a rubber or impression stamp being used for the purpose.

In some instances the bottles are hermetically sealed with paraffin, which is protected by parchment, tin foil or tin covers bearing the term "certified," the name of the dairy and the name of the Medical Milk Commission. The caps are sometimes sold to the dairymen by the commissions and funds are thus provided for defraying the necessary expenses, including inspections, chemical analyses, etc. In other instances funds are provided by the medical society, the dairyman or by means of a bottle tax.

CHAPTER X

ESSENTIALS OF MILK BACTERIOLOGY

By H. W. Hill, M. D.

THE Bacteria are very minute living things, which feed chiefly on the waste matters of animal and vegetable life, and on dead animal and vegetable bodies. There are many kinds of bacteria, one differing from another in size to some extent, in shape to some extent, but chiefly in the way they live—the kind of food they prefer, the kind of atmosphere they need, the temperature at which they will develop, the products they form from their food, the shape and naked-eye appearance of their mass growths. Hence, although the size and shape of any given bacterium helps towards its recognition, it must be tested in many ways to determine the foods it uses, its effect on its foods, the temperature and atmosphere best suited to it, and other details, before any one who examines it can determine its identity. No bacteriologist can recognize what bacterium he is dealing with by merely looking at it with a microscope, except in a very few special cases.

The bacteria have no sex. New ones are formed simply by the division of the old ones into two (fission). Size, shape and arrangement, *i. e.*, grouping of individuals in chains, clusters, etc., are studied under the term morphology; the essentials of growth, reproduction, food, chemical products, etc., under physiology.

Size.—The diameters of the bacteria in general range from about 1/25,000 of an inch (or 1/1000 of a millimeter, which is

called 1 μ or mu or micron) to three or four times as much. The diameter of the individuals belonging to any one species varies very little. The length of bacteria in general ranges from 1/25,000 of an inch to very many times that figure—perhaps to 1/16 of an inch or more amongst the higher bacteria, but these very long forms are twisted and curled, never extended in a straight line. The length of the individuals belonging to any one species varies very greatly, according to age and other conditions. Hence, in examining bacteria under the microscope, great differences in length do not necessarily indicate that more than one species is present; but if differences in diameter are found, the observer may feel pretty certain that he is dealing with a mixture of several kinds; on the other hand, it is quite possible to have two different kinds of the same diameter: in such cases the shape of the individuals may assist in deciding whether one or more kinds are present.

Shape.—The bacteria present very simple symmetrical outlines—so simple that there is little room for great differences between them. The simplest form is spheroidal, some kinds being truly round, others flattened slightly. The rest of the bacteria are more or less cylindrical. Of these cylindrical forms, some are short, others very long, others intermediate. The short cylindrical bacteria are, in some species, twisted spirally. Some few bacteria branch.

Structure of Bacteria.—The individual bacterium is composed of practically the same material as are all other living things—protoplasm. Chemical tests cannot distinguish the protoplasm of the animal from that of the vegetable, nor the protoplasm of either of these from the protoplasm of the bacterium. That the protoplasm of the animal varies, nevertheless, from that of the vegetable, and both from bacterial protoplasm, is known, because each grows and acts in a manner peculiar to itself in many details. The minute particle of protoplasm which forms a bacterium is enclosed in a wall, composed of a chitin-like material similar to that which forms the

carapace of the lobster, or the outer wing-cases of beetles. Vegetable protoplasm, on the other hand, is contained usually in a cell wall of cellulose, while animal protoplasm has no wall distinct in composition from its own substance. The protoplasm of the bacterium, contained in its surrounding wall, forms what is called a cell, and since each such cell, amongst the bacteria, is complete in itself and capable of independent existence, feeding, growing, multiplying, excreting, dying, the bacteria are spoken of as uni-cellular organisms. Some minute vegetable and animal organisms are uni-cellular also, but the larger forms are composed of many cells attached to each other and interdependent on each other. This interdependence is due to the fact that in such multicellular organisms specialization has gone on, so that certain cells secrete digestive juices, other cells are devoted to reproduction and so on. Amongst the uni-cellular organisms, each cell performs all these functions itself.

Besides the cell-wall and its protoplasmic contents, both of which all bacteria possess, some bacteria possess flagella, or fine hairlike whips only to be seen by special methods of staining, the use of which is to propel the bacterium possessing them through liquid—they are the swimming organs of the “motile” bacteria. Bacteria without flagella are incapable of swimming and are called non-motile. Motility, *i. e.*, true purposive swimming movements, must be distinguished from the Brownian movement. This is a vibratory, sometimes circular motion which all minute particles suspended in liquid are likely to show, due to the delicacy with which they are held balanced in liquids, and the constant direct transmission to the liquid of minute vibrations from outside. Particles of resin, milk globules, dust particles, dead bacteria, etc., suspended in liquid show this movement. In case of doubt between motility and Brownian movement, the distinction can be based on the translation from place to place, resulting from motility, in contrast to the absence of movement from place to place (except within the

small area of the vibratory motion), seen in true Brownian movement. Brownian movement of a particle combined with an actual current in the liquid in which it is suspended may give an appearance of actual translatory motion much like true living motility, but can be distinguished from it in that the current movement is all in some one direction, while individual bacteria showing motility move in various directions.

Certain bacteria at certain stages (generally when growth has occurred rapidly in one place for a considerable number of hours, resulting in food exhaustion; or, more often, from the accumulation of bacterial excreta in sufficient amount to obstruct further growth by poisoning the living bacteria; or when drying, if it occurs slowly) form spores, which are bodies developed in the cell (one spore to one cell usually) containing the living protoplasm of the cell in a dormant state, and having a spore wall of greater strength and resistance than the wall of the parent cell. A cell containing a spore is called a sporangium. The sporangium soon disintegrates, setting the spore free. The spore remains alive but dormant until it reaches a locality where conditions of food, temperature, etc., are favorable, whereupon it germinates—*i. e.*, the protoplasm within it becomes active and begins to grow, escaping from the confines of the spore wall and resuming existence in the identical form and activities of its parent cell. Spores are particularly important to the milk bacteriologist, because the measures of sterilization, etc., wholly efficient in the case of the ordinary bacterial cell, may fail if spores are present, since the latter are much more resistant to heat, drying, chemical reagents, etc., than the adult bacterial cell.

“Capsules” show themselves as oval rings or halos, surrounding bacterial cells. They are to be found more readily in some species than in others, although by no means constantly in any species. It cannot be doubted that many appearances interpreted as indicating capsules are really artefacts or optical illusions. Nevertheless it is not improbable that a true bacterial substance

does at times exist surrounding the bacterial cell outside of the cell wall, as the white of an egg surrounds the yolk. Whether this is a secretion of the cell or a mere swelling up of the cell-wall, or sometimes one, sometimes the other, is not known.

Classification.—The bacteria have for convenience been divided according to shape into families: the families have been divided, partly according to shape, partly according to structure or methods of fission, into genera; the genera have been divided, partly according to shape and structure but chiefly according to methods and conditions of growth, into species. (See p. 281 for families and genera. Chester's Manual of Determinative Bacteriology is the most useful of the works in English for the recognition of species.) But besides this formal classification, now becoming slowly accepted, a rougher classification has been in use for many years, and is still largely employed. This informal classification furnishes many of the names in common use and follows here.

LOWER BACTERIA.

Coccus (from Greek, *kokkus*, a berry)—spheroidal bacteria (plural, *cocci*).

Micrococcus—a synonym of coccus.

Diplococcus—a coccus, the individuals of which are generally attached together in pairs.

Staphylococcus—a coccus arranged chiefly in clusters.

Streptococcus—a coccus arranged chiefly in chains.

Tetracoccus—a coccus arranged chiefly in flat groups of four or more.

Sarcina—a coccus arranged chiefly in cubical packets of four or more *to each side*.

Bacillus—cylindroidal bacteria, straight or curved, but not spiral (plural, *bacilli*).

—diplobacillus—a bacillus arranged chiefly in pairs.

—streptobacillus—a bacillus arranged chiefly in chains.

Spirillum—cylindroidal bacteria, having a spiral twist. (Plural, spirilla.) Very often the spiral twist is so slight, that single individuals appear like commas—hence the term comma bacillus, which really indicates a short spirillum. When in chains, however, the spiral twist is very evident.

HIGHER BACTERIA.

The much elongated or filamentous forms, included in the Migula-Chester classification, as streptothrix and chlamydo-bacteriaca. (Note.—The “mycobacterium” of this classification is still often regarded and spoken of as “bacillus.”)

Whether bacteria are animal or vegetable in character is not settled—and matters little. They resemble both in many features, and differ from both in many others. At first considered animal, they were later believed to be vegetable, but now it is admitted that their exact position is not clear.

Essentials of Bacterial life.—All living bacteria exist in one of two conditions, the active growing multiplying condition and the dormant or quiescent condition. The quiescent condition is reached as the result of food exhaustion or poisoning with their own excreta, drying or other unfavorable conditions; those bacteria which form spores have therefore two quiescent conditions, the spore, and the quiescent condition common to all bacterial cell. The dormant condition of the non-spore-bearing bacterial cell, due to self-poisoning from its excreta, is likely to terminate in the death of the organism and its destruction by its own products (autolysis) if the material in which it lies remains moist: if drying occurs, however, before the death of the cell, it will become dormant but remain alive and resistant to outside influences for considerable periods, returning to the active condition if it reaches favorable surroundings; but the quiescent condition of the cell is not so resistant as the spore state.

Spores are found when drying is slow: if drying occurs rapidly, the adult form goes into the quiescent condition directly.

What are the conditions favorable to bacterial growth? Suitable food (which includes amongst other things a suitable concentration, and a neutral or nearly neutral reaction); suitable temperature; suitable atmosphere; high humidity and darkness.

Suitable Food.—In general, bacteria use as foods all waste products of animal or vegetable life and the dead materials of the animal or vegetable body; some bacteria, however, can grow in wholly inorganic solutions and some refuse to grow except in such solutions. The food must not be present in too great a proportion to the water present (*i. e.*, the concentration must be low), and there must be only small amounts of free acid or alkali. (See media used in bacteriology, p. 264.) Bacterial food, in suitable condition as to concentration, reaction, and absence of anything injurious to bacterial life, *i. e.*, ready for bacterial use, is called medium (plural, media).

Suitable Temperature.—Most bacteria grow best at about 20° C. to 40° C.; some prefer the neighborhood of 22° C. (room temperature), some 37° C. (body temperature), others refuse to grow except at or about one temperature, 22° or 37° C. as the case may be. Species are known which flourish best at 0° C.; others which flourish best at 60° to 70° C. (hot springs—manure). The laboratory incubator is usually regulated to run at 37° to 38° C.

Suitable Atmosphere.—Some bacteria grow only in the presence of free oxygen (strict aerobes); some only in the absence of oxygen (strict anaerobes); many grow equally well under either condition; or grow under both conditions, preferring one, however (facultative aerobes or anaerobes). Bacteria grown in the laboratory without special precautions to exclude air must necessarily be aerobic, strict or facultative.

High Humidity.—All bacteria in the active state require the presence of a great proportion of water: water dissolves their foods, dilutes their excreta, and acts as a vehicle for their movements; but above all, water is necessary for the passage of food materials inward through the cell wall and for the passage of excreta outward. Water forms 90% or more of the ordinary laboratory media. To prevent concentration of the media by evaporation in the incubator, the tubes may be sealed, or, more conveniently, water kept in bowls, etc., in the incubator.

Darkness.—Unlike most other living things, animal and vegetable, direct sunlight is fatal to bacteria in a short time, diffuse sunlight in a longer time; absolute darkness favoring them most. The incubator, and, in fact, all containers used for bacterial cultures, should be absolutely dark.

Identification.—The recognition of a given bacterium as belonging to a certain species involves:

1st. Isolation—by plating and selecting colonies for reinoculation (see p. 256).

2nd. Working out the characteristics of the isolated cultures—preferably following the form suggested by the Soc. Am. Bact. (see p. 282).

3rd. The comparison of the features thus determined with those already described by other workers, as in Chester's Manual, or similar tabulated descriptions. Certain well known bacteria (*B. coli*, *B. tuberculosis*, *streptococci*, etc.) can be determined by certain special tests without doing the elaborate work in full above outlined. These tests are described in their proper places.

CHAPTER XI

QUANTITATIVE BACTERIAL ANALYSIS OF MILK

Significance of Bacterial Counts.—The bacterial count means the numerical determination of the “growable bacteria” (*i. e.*, growable under the circumstances of the test as to medium, temperature, humidity, darkness, presence or absence of oxygen, and length of time allowed for growth) in the sample examined, expressed as “number of bacteria per c.c.”

Bacteria cannot be accurately counted directly under the microscope; except when present in such immense numbers that (Winslow; Slack) the merest estimate alone is required. Such a method is not practical for certified or even inspected milk, although used with success for standards of 500,000; hence the count is made by plating the original sample or dilutions therefrom, *i. e.*, mixing them with melted nutrient jelly, pouring the mixture into a flat dish, and after cooling the jelly, allowing growth to take place. The individual bacteria, held apart by the jelly, develop, producing little aggregations of their descendants (colonies); and since each bacterium produces but one such colony, a count of the colonies indicates the number of the bacteria originally present. Thus, if two hundred (growable) bacteria are present in the water, etc., which is mixed with the melted jelly, 200 colonies, or one for each bacterium, should grow in the plate. It has been found by experience and experiment that the ordinary “agar plate” will not support

the growth of more than 200 bacterial colonies of countable size, without suppression of some of the weaker forms. Should there be in the material (milk, water, etc.) mixed with the standard 10 c.c. of jelly a very large number of growable bacteria, say 2,000,000, the colonies produced would not generally greatly exceed 10,000 to 20,000 and these would be exceedingly small colonies—barely visible to the naked eye. In other words, placing 2,000,000 bacteria in 10 c. c. of medium is like planting a thousand grains of corn in a flower-pot full of earth—only a very few of the strongest and most favorably situated will survive and grow up. To grow from 2,000,000 bacteria successfully, 2,000,000 separate colonies, they should be planted in 100,000 c.c. of jelly—a totally impracticable amount. Hence the practice is to reduce the number of bacteria plated, rather than to increase the food, until the due proportion of 200 bacteria per 10 c.c. of medium is reached, at which point all present capable of growing at all have freedom to grow, without the weaker suffering from the competition of the stronger forms. To secure this end, samples containing large numbers of bacteria per c.c. must be plated in such a manner that only such very small fractions of a whole c.c. are placed in each plate as will contain but 200 bacteria per fraction. It is of course impossible to determine accurately what number of bacteria are present in a given sample before plating (except by Slack's preliminary microscopic count); otherwise, why make a plate count? Hence it is impossible to determine exactly what fraction of 1 c.c. to use in order to secure 200 bacteria per plate. The practice is therefore to plate several different fractions (say 1/10 c.c., 1/100 c.c., 1/1000 c.c., etc.) of the original sample, and to select that plate which gives 40—200 bacteria as the one which represents the true number of bacteria. The number of colonies in this plate, multiplied by the dilution it represents, gives the number per c.c.

Thus—If 2,000,000 bacteria (growable) exist in each c.c. of

a given milk sample, and if successive decimal fractions of 1 c.c. are taken for plating, the plates will contain as follows:

Plate No.	1	2	3	4	5	6
1 c. c.	1/10	1/100	1/1,000	1/10,000	1/100,000	

The number of bacteria thus placed in each plate will be

2,000,000 200,000 20,000 2,000 200 20

But the colonies produced by these will be (approximately)

10,000	9,000	7,000	1,400	200	$\left\{ \begin{array}{l} 15 \\ 25 \\ 30 \end{array} \right.$
--------	-------	-------	-------	-----	---

Knowing that plates containing over 200 do not develop a colony for each growable bacterium placed in it, but only for the strongest ones, reject all but plate No. 5. This contains 200 colonies; they developed from 1/10,000 c.c. of the sample; hence 1 c.c. of the sample must contain $200 \times 10,000 = 2,000,000$ colonies.

On the other hand, counts below 40 colonies per plate are also unreliable, from the mechanical difficulties attendant on removing so small a number accurately from a mixture. If a dilution is made so low as to secure only 10—30 colonies per plate (as in No. 6 plate above), the chances of any one plate showing a number of colonies truly corresponding with the dilution made is rather small. Plate No. 6 is so diluted that the proper proportion is only 20 colonies per plate, but the chances are that 15 or 30 or some other number rather than 20 (but not far from it) will actually grow. It will be seen that the error introduced by considering such low dilution accurate would be in the case given reporting of a count of 1,500,000, 2,500,000 or 3,000,000, whereas the true count is 2,000,000.

It is quite important to thoroughly understand this principle, as great errors in reporting counts may obviously be made if they are neglected. Thus, if seven different laboratories report on a

given milk supply using identical technique and each securing the same set of counts from the dilutions made, but differing as to calculation of count, they might report from such figures as the above, no less than seven different results, all justified by existing (but erroneous) methods of calculation. Owing to the fact that it is not usually the custom to make more than two or three dilutions, and these not necessarily the same, the actual number of possible reports from the same milk if badly contaminated is about fifteen, ranging from 25,000 to 2,000,000.

If different techniques are used, especially as regards medium, temperature and time of incubation, results differing from 50% to 200% may be obtained from the same sample, even using the same methods of calculation. *Hence the absolutely essential need for uniformity of technique and uniformity of calculation. Neither one alone will give figures of any moment whatever.*

Interpretation of Count.—Attention to condition of cow, cleanliness, cold, and quickness in transportation, as described elsewhere in this book, will alone secure low count milk. Failure in any one of these essentials is faithfully recorded by the bacterial count. Indeed, the bacteria in milk may be regarded, from the standpoint of the sanitary milk inspector, as a tell-tale or automatic register, of the treatment the sample tested has received in these regards. Neglect of any necessary precaution is written down by these faithful "recording angels" for the bacteriologist to read.

The simple count, taken alone, while it gives the sum total effect of whatever mistreatment the milk may have received, does not indicate what the mistreatment was, *i. e.*, whether it lay in neglect of the cow, admission of dirt, high temperature, or lapse of time. If the differentiation of these is desired, it may be achieved only by learning the history of the milk, and thus determining which factor or factors suffered neglect. If the history of the milk shows delay in transportation, especially with lack of cool-

ing in transit, a dirty, dusty barn, utensils, or animal, or a gargety cow, the count may be attributed to these.

Confirmation of these may be obtained in two directions—the height of the count and the character of the bacteria present, the latter involving considerable additional bacteriological work for its final determination. This outline cannot be considered wholly final, but as yielding strong indications, which should be confirmed by actual investigation.

A high count, almost wholly consisting of lactic acid bacilli = probability of slow transit, at a temperature of 60°—80°. (The acidity of such a sample would be high.)

A high count, with a variety of bacteria, lactic acid bacilli not prominent = probability of slow transit at low temperatures, 30° to 50°. (The acidity of the sample would be moderate.)

A high count, showing many spore-forming bacteria, without great acidity = probability of pasteurization, followed by too long keeping at too high a temperature.

A high count, showing a very large variety of forms, especially fluorescent and chromogenic forms, suggests extensive contamination from dust, etc., or possibly from watering. If the milk is fresh and not very acid, the "dirt" origin of the bacteria is largely confirmed.

A high count, consisting chiefly of streptococcus colonies, points to a gargety condition in the cow.

A low plate count, since it gives the living bacteria, combined with a high direct count by Slack's method, since this gives dead as well as living bacteria, suggests recent pasteurization of a high count milk.

The propositions converse to the above will not always hold true, however, and many combinations arise, the interpretation of which cannot be made easily, since frequently many of the factors given operate at one time, but in different proportions in different cases. Only the simpler basic combinations are stated here. The

milk bacteriologist engaged in daily examinations must learn to deduce for himself the more intricate inter-relations which arise.

The determination of species is difficult and intricate work, to be attempted on a large scale only by those who have much time and energy to devote to it. The required tests are given on page 282. The careful working out of a culture isolated from a plate on the various media, by the methods there outlined, and comparison of the results with some text-book giving the various species in groups for identification, is the only wholly satisfactory way.

Streptococci may be recognized by the method outlined in standard methods of milk analysis.* Tubercle bacilli will not be found in plates, being slow growers at best and plain nutrient agar being a very poor medium for their growth. They may be found by staining the cream or sediment of centrifugalized milk by the Ziehl-Nielsen method, which shows them red on a blue ground. Failing this, inoculations into guinea pigs from the same sources should be tried.

Objections to the Numerical Standard.—1. That the sample examined can never be condemned in time to prevent use of the milk by the consumer, since the results are not available for at least 24 hours, hence only the dairy which supplied that sample can be held responsible in a general way for putting it on the market. Of course this objection applies to any system of analysis which takes more than a few minutes—such as the mere testing of temperature (as advocated in New York) or the microscopic count advocated by Slack.

It has been shown conclusively (Boston Board of Health Reports) that the temperature test is absolutely fallacious in distinguishing high and low count milk, since it indicates only the temperature at the moment of the test—not how long that temperature

* Very small white colonies, on agar plates after 24 hours, which yield diplococci in smears, but which, transferred to broth at 37° C., yield chains of cocci.

has existed. A logical application of the temperature test would require a test at each dairy, another at each receiving and shipping station, and another at the wagon, besides information as to conditions en route and in storage. Slack's method, while applicable to comparatively lenient standards, such as 500,000 per c.c., is not sufficiently accurate for more severe standards, such as those required for inspected (100,000 per c.c.) and certified (10,000 per c.c.) milk.

Since the very object of the test is, not to determine the harmfulness of a particular sample, but how well the dairy it came from is supervising every step in the production of good milk, the objections on these scores are entirely misplaced.

2. The condemning of clean milk kept too long at too high a temperature, as against the passing of dirty milk, shrewdly cooled at once to a low point.

This objection would have some weight, if it were true. However, the dirty milk can be detected despite the cooling, since neglect of this one factor will raise the count; while the clean milk, poorly iced and long delayed, should be condemned, since its virtues in one direction are offset by neglect in another. It has been demonstrated again and again, even by the objectors, that dirty methods result in an immediate and enormous rise in the count, and while *subsequent development* may be restrained by cooling, the initial rise cannot be concealed.

3. That the numerical count cannot ensure the wholesomeness of milk. This is perfectly true. A milk containing a count of 500,000 lactic acid bacilli and hence barely passable as "market milk" by the most lenient standards, may be absolutely harmless; while a milk of 5,000 count, hence well under the highest standards for certified milk, may cause infinite harm should all or even one-tenth of these be typhoid bacilli.

Such an argument, however, is beside the point. No one objects to inspection for adulteration, watering, etc., although admit-

tedly nine-tenths of such watering is perfectly harmless. The object of the numerical standard is *not* primarily to secure a low count, but *fresh, sweet, pure milk, from healthy cows*. No dealer failing in any one of these features can secure a low count in milk, and his failures, undetectable otherwise without tremendous cost and labor in inspection, can be determined very simply and accurately by the numerical standard. Such a standard will not secure the exclusion of individual accidents—no method will do that—but it will ensure and compel a very high average of freedom from undesirable conditions.

4. That the bacterial count cannot be legally enforced is a matter easily offset by the fact that it has been legally enforced in Boston. It is true that in the chaotic condition lately existing as to technique and methods of calculation, it would have been, and for some time yet will be, easy to secure contradictory reports from "experts," or to produce evidence of the unstandardized methods existing in too many laboratories. With a general recognition amongst laboratory men and public health executives that the numerical standard cannot properly be stated merely as a fixed figure, but as a fixed figure *obtained by standard methods of technique and calculation*, these difficulties will quickly disappear. A great deal has already been accomplished through the agency chiefly of the bacterial count, and more will be, as its strength and weaknesses become better known. But the bacterial count is simply a method of inspection, readily and easily applied to great numbers of samples in a short time, with but few men. It is not in itself an automatic reformer of the dairy, the milk handler or the milk peddler. It is a test, like litmus, to determine results: it is not except indirectly a producer of those results.

A most useful application of the bacterial count is made by those large milk concerns, who through their own private bacteriological laboratories, exercise supervision over the dairies supplying

milk to them in a direct individual manner impossible to large municipalities.

Another application, and one likely to develop rapidly in the future, is the establishment of bacteriological laboratories at the dairies themselves, so that each dairy may control its own product in the first place. Naturally this is only likely to be done where the dairy is a large one, and is devoted to the production of clean milk as a business.

Standard Counts for Milk.—Experience and experiment have crystallized the opinions held by most sanitarians into a set of standards voiced by A. D. Melvin, Chief of the Department of Agriculture, as follows: for certified milk, a limit of 10,000 per c.c. when delivered to the consumer; for inspected milk, a limit of 100,000 per c.c. when delivered to the consumer. All milk above this point should be pasteurized before sale is permitted, according to some authorities. This at present is an academic requirement, especially in large cities. Hence Boston and some other cities and the State of Minnesota permit 500,000 per c.c. in market milk.

EXAMINATIONS FOR "PUS" IN MILK.

This subject has been so much discussed and so many methods and objections to methods have been proposed that only a much more extended account than is possible here could adequately treat the subject. At present writing the tendency is to consider the test of chief value for municipal milk inspection and analysis, where the actual routine veterinary examination of all cows cannot be done. The finding of an unusually high cellular content by any method should lead to investigation of the dairy supplying the milk in question. Often cows suffering from mammitis or garget are found in this way. On the other hand, it has apparently been well established that cows giving unusually high cellular content have been found in which no veterinary examination, however careful,

could detect any lesion or disease. The Committee on Standard Methods, already quoted, gives only guarded recommendations on this point, awaiting further evidence. Those who wish to follow the literature will find an excellent bibliography in the Reports of the Committee (the second report will now soon appear).

EXAMINATIONS FOR STREPTOCOCCI IN MILK.

The smear method of Slack (see Report of Committee on Standard Method; also used for the detection of pus in milk) or the recognition and isolation of colonies of streptococci from plates made for counting purposes may be followed. The significance of streptococci in milk is almost as much in dispute as is the significance of "pus." In general it may be stated that any number exceeding the ordinary number found in milk calls for investigation of the dairy supplying the milk, with individual inspection of the cows for mammitis, etc., and critical inspection of methods relating to exclusion of dirt, particularly of manure, from the milk. The standards adopted for the maximum number of streptococci which may be found without calling for such investigations, like the standards for "pus," have varied much in different places.

STANDARDS FOR PUS AND STREPTOCOCCI.*

Standards adopted tentatively in Boston have been followed elsewhere and, while no final value can be claimed for them, are quoted below, from a private communication made by Dr. F. H. Slack, Director of the Boston Board of Health Bacteriological Laboratory. The truth seems to be that while injustice may sometimes be done to the farmer in condemning a milk for "pus" when as a matter of fact the milk may come from a normal cow contributing a number of leucocytes to the milk in excess of those usually contributed by most cows, yet the failure to insist on such a

* For proposed standards, see pp. 295, 349.

standard more often does injustice to the consumer, since a high leucocytic count *usually* indicates an abnormal cow.

COLLECTION OF SAMPLES.

(From Preliminary Report of Committee on Standard Methods.)

Quantity of Milk Required for Analysis.—The minimum quantity of milk necessary for making an ordinary bacteriological examination is ten cubic centimeters. When making examinations for certified milk, if possible a pint or quart bottle should be taken and brought to the laboratory unopened.

Collecting Apparatus.—In collecting milk samples for bacteriological examination it is essential that the sample be taken and kept in such a manner as to prevent either any addition of bacteria from without or multiplication of the bacteria originally present. Bottles, tubes, pipettes, etc., used in the collection of samples, besides being washed, shall be sterilized with dry heat for an hour at or about 160° C., or to the charring point of cotton.

In the selection of "certified milk" samples it is recommended wherever possible that an unopened bottle be taken, placed in a suitably iced case and brought at once to the laboratory.

Samples of "market milk" may be collected as are water samples, in sterile, wide-mouthed, glass-stoppered four-ounce bottles; the case in which they are carried being well iced. The principal difficulty encountered in this method is in transferring the sample from the original container to the bottle, and the various string and wire devices by means of which the bottle is immersed in the original container are objectionable both on account of the labor of preparing such an outfit and also on account of the coating of milk left on the outside of the bottle when the sample has been taken.

An apparatus designed for the use of thirty-two test tubes

as containers * is recommended as superior to one designed for bottles (Fig. 62).

It has been proven that with samples kept properly iced in this particular form of case there is no increase of bacterial content even after twenty-four hours, but rather a slight decrease, the counts varying hardly more than might be expected in duplicate plates. It is recommended, however, that examination of the samples be proceeded with as quickly as possible after the collections are made.

Fig. 62.

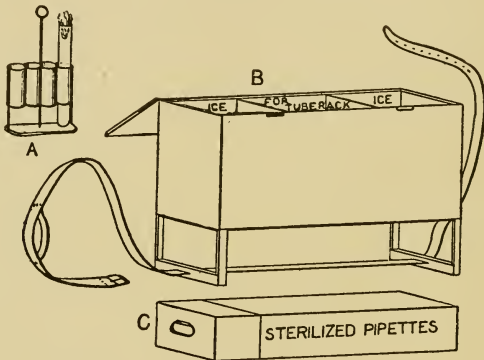

Boston Board of Health—collecting case for milk samples. (After Conn.)

The samples are removed from the cans with sterilized pipettes, and placed in tubes. These are placed in weighted racks (A) and put into the center compartment of the carrying case.

Identification of Samples.—When bottles are used identification numbers should be etched on both bottle and stopper. Test tubes should be labeled or etched and numbered.

A complete record of the samples taken, giving date, time, place, name of party from which sample is taken, name of collector, temperature of milk, character of original container (tank, can,

* Am. Jour. Pub. Hyg., Nov. '04.

bottle), etc., should be written opposite duplicate numbers in a blank book or pocket card catalogue, or this information may be written on small tags and tied or wired to the corresponding test tube or bottle.

Temperature.—The temperature should be taken immediately after taking the sample for analysis, while the milk is still thoroughly mixed.

If it is desired to take the temperature of "certified milk," this should be done when the sample is taken, but from another bottle.

A floating thermometer, graduated to the Fahrenheit scale, is most convenient, and the temperature should be expressed to the nearest degree. It is necessary to standardize the thermometer for at least ten degrees on each side of the legal temperature limit. A quickly registering thermometer should be left at least one minute in the milk and read as soon as removed. A small piece of clean absorbent cotton may be used to wipe the adhering milk from the thermometer that the scale may be easily seen.

Representative Samples.—The collector should always select his own sample, and care should be taken to secure a sample which is truly representative of the milk to be examined.

One of several methods of mixing the milk may be used, comparison having shown the results to be practically the same.

1. Pouring the milk into a sterile receptacle and back.
2. Shaking the milk thoroughly with receptacle turned upside down. (This may be done where the can or bottle is tightly stoppered or capped and is not so full as to prevent thorough agitation.)
3. In open tanks in stores it is allowable to stir thoroughly with the long-handled dipper generally found in use.
4. Where the test tube collecting case is used, thoroughly reliable results are secured by first shaking the can or bottle; and, second, stirring with the large pipette before taking the sample,

care being taken to close the upper end of the pipette with the finger so that no milk enters until after the mixing; or the pipette may be emptied after stirring before the sample is taken.

5. For certified milk samples it is recommended that, on arrival at the laboratory, the bottle be opened with aseptic precautions and the milk thoroughly mixed by pouring back and forth between the original bottle and a sterile bottle. Another method is to mix as thoroughly as possible by agitation for five minutes, then burn through the pasteboard stopper with a hot iron and remove the desired amount of milk with a sterile pipette.

THE INTERVAL BETWEEN COLLECTIONS AND ANALYSIS.

Generally speaking, the shorter the time between the collection and examination of milk samples the more accurate will be the results. For routine work the attempt should be made to plate within four hours of the time of collection.

Too much stress cannot be laid on keeping the samples properly iced during this interval. They should be kept below 40° F., but care should be taken that they are not frozen.

DILUTIONS.

Ordinary potable water, sterilized, may be used for dilutions. Occasionally spore forms are found in such water which resist ordinary autoclave sterilization; in such cases distilled water may be used or the autoclave pressure increased. With dilution water in eight-ounce bottles calibrated for ninety-nine cubic centimeters and in test tubes calibrated for nine cubic centimeters, all the necessary dilutions can be made.

Short, wide-mouthed "Blakes" or wide-mouthed French square bottles are more easily handled and more economical of space than other forms of bottles or flasks.

Eight-ounce bottles are the best, as the required amount of dilution water only about half fills them, leaving room for shaking. Long-fiber, non-absorbent cotton should be used for plugs. It is well to use care in selecting cotton for this purpose to avoid short-fiber or "dusty" cotton, which gives a cloud of lint-like particles on shaking. Bottles and tubes should be filled a little over the 99 c.c. and 9 c.c. marks to allow for loss during sterilization.*

The dilutions recommended are 1/10, 1/100, 1/1,000, 1/10,000, 1/100,000 and 1/1,000,000.

For certified milk the 1/10 and 1/100 dilutions should be used, while the 1/10,000 will usually be found best for market milk.

The 1/10 dilution is prepared by shaking the milk sample twenty-five times and then transferring 1 c.c. of the milk to a test tube containing 9 c.c. of sterile water.

The 1/100 dilution is prepared in the same way, except that a bottle with 99 c.c. of sterile water is substituted for the test tube.

The 1/1,000 dilution is prepared by first making the 1/100 dilution, shaking twenty-five times and transferring 1 c.c. of the dilution to a test tube containing 9 c.c. of sterile water.

The 1/10,000, 1/100,000 and 1/1,000,000 dilutions are made in the same manner by dilutions of the 1/100, 1/1,000 and 1/10,000 dilutions, 1 c.c. to 99 c.c. of sterile water.

It is recommended that that dilution be used which will produce about two hundred colonies to a plate, ranging from 40 to 400; where a 1/10 dilution exceeds this number the 1/100 dilution is more accurate, etc. The number of bacteria present may if desired be approximately estimated before dilutions are made by direct microscopic examination of a properly prepared sediment. Otherwise it is necessary to make a range of dilutions, thereafter select-

* If the loss during sterilization has not sufficed to bring the water level down to the marks, sufficient water may be further removed with a sterile pipette. If sterilization has removed a little too much, sufficient sterile water may be added with a sterile pipette. Ordinarily, however, experience will show how much to overfill before sterilization, so that no change is required afterwards.

ing for record the count obtained on that plate which yields between 40 and 400 colonies.

Plating undiluted milk is unreliable, whatever quantities be used, since the bacteria are not so well separated as in the dilutions, and often, owing to the crowded conditions, only a portion of the bacteria present will develop into visible colonies. Moreover, if a cubic centimeter of the milk is used, the turbidity of the jelly, due to the presence of the milk, hides the colonies present from the eye.*.

MEDIA.

The standard medium for determining the number of bacteria in milk shall for the present be agar, made according to the recommendations of the Committee on Water Analysis, except that the percentage of agar shall be 1% and the reaction + 1.5.

All variations from agar media made as described shall be considered as special media.

Much work yet remains to be done on media; the above is recommended as giving the highest and most uniform counts so far as our comparative work has extended and with but slight variations is the medium in most common use.

Storage of Media.—Media may be made up in quantity, tubed and stored (preferably in an ice chamber).

PLATING.†

Plating Apparatus.—For plating it is best to have a single water bath in which to melt the media and a water-jacketed water bath for keeping it at the proper temperature; a wire rack, which should fit both of the water baths, for holding the media tubes;

* The old practice was to plate, not 1 c.c. of a dilution, varying the dilution to suit conditions, as described above, but to plate the undiluted sample in fractional portions of a c.c. While mathematically the same amount of milk is plated, whether $\frac{1}{100}$ c.c. of undiluted milk or 1 c.c. of a dilution of 1 to 99 be used, in practice the latter is superior, for the reasons given above.

† A method of avoiding troubles due to moisture consists of inverting the plates and putting in the lid of each petri dish a strip of blotting paper on which there is a large drop of glycerine. Incubate as directed. (Extract from 1908 Report of American Public Health Association.)

a thermometer for recording the temperature of the water in the water-jacketed bath; sterile 1 c.c. pipettes; sterile petri dishes; and sterile dilution water in measured quantities.

For milk work porous earthenware petri dish covers (Fig. 63) are much superior to glass covers, since they absorb the excess moisture from the agar and prevent "spreading."

It is quite essential to the best results that the porous covers should be wet as seldom as possible. In sterilizing them the process should be prolonged beyond the time necessary to kill the organisms in order that the covers may be thoroughly dry.

Straight-sided 1 c.c. pipettes are more easily handled than

Fig. 63.

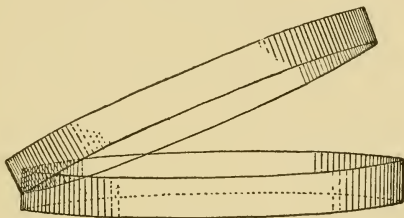

Petri Dishes.

those with bulbs; they may be made from ordinary glass tubing about $3/16$ of an inch in diameter and calibrated in the laboratory. They should be made about 10 inches in length.

Plating Technique.—The agar after melting should be kept in the water-jacketed water bath between 40° C. and 45° C. for at least fifteen minutes before using, to make sure that the agar itself has reached the temperature of the surrounding water. If used too warm the heat may destroy some of the bacteria or retard their growth. Below this temperature the agar tends quickly to solidify.

For routine work in cities in order to bring down the actual number of colonies in a plate around the standard of two hundred,

it is well to use a dilution of $1/10,000$. To make this dilution, use Fig. 64. two bottles of sterile water each containing 99 c.c.



1 c. c. pipettes enclosed in tubes for sterilizing.

Shake the milk sample twenty-five times, then with a sterile pipette remove 1 c.c., put into the first dilution water and rinse the pipette by drawing dilution water to the mark and expelling; this gives a dilution of 1 to 100.

Shake the first dilution twenty-five times, then with a fresh sterile pipette remove 1 c.c., put into the second dilution water, rinsing the pipette to the mark as before; this gives a dilution of 1 to 10,000. Shake the second dilution twenty-five times, then with a sterile pipette remove 1 c.c. and put it into the petri dish, using care to raise the cover only so far as necessary to insert the end of the pipette.

Taking a tube of agar from the water bath, wipe the water from outside the tube with a piece of cloth, remove the plug, pass the mouth of the tube through the flame, and pour the agar into the plate, using the same care as before to avoid exposure of the plate contents to the air.

Carefully and thoroughly mix the agar and diluted milk in the petri dish by a rotary motion, avoiding the formation of air bubbles or slopping the agar, and after allowing the agar to harden for at least fifteen minutes at room temperature place the dish bottom down in the incubator. The practice of mixing the diluted milk with the agar *in the tube* leaving a certain portion of the bacteria unplated, is not recommended by the Committee.

Controls.—Plating should always be checked by controls. A blank plate should be made with each set of milk plates for control of the water, petri dishes, pipettes, etc.

For control on technique of plating it is recommended that for work on "market milk," duplicates be made each day on several plates.

"Certified milk" should always be plated in duplicate, and

where possible it is well to have one man's work occasionally checked by another.

Unless duplicate plates show as a rule approximately the same count, the worker should see if there is error in his technique.

Racks are very useful for stacking the plates and to prevent breakage.

Plating should be done always in a place free from dust or currents of air.

In order that the colonies may have sufficient food for proper development, 10 c.c. of agar shall be used for each plate. In plating a large number of samples at one time the dilution and transfer of diluted milk to the plates may be done for four or eight samples, then the agar poured, one tube to each plate, then another eight samples diluted, etc.

INCUBATION.*

Concerning incubation two methods are at present in use. Three-fifths of the laboratory workers consulted recommended incubation at 37° C. for twenty-four hours with saturated atmosphere, the remaining two-fifths allowed varying lengths of time at different degrees of room temperature and at whatever degree of humidity happened to obtain.

When considering these two methods many advantages of the method of incubation at 37° C. are evident, including the ease of maintaining this temperature in any laboratory, the evident uniformity of counts so obtained in different places as compared with those obtained by the varying methods of technique, as to temperature and incubation period, where room temperature is employed, and the quickness with which results are obtained, doing away with large accumulations of uncounted plates.

Forty-eight hour plates grown at 37° C. give a slightly higher count, not enough higher to materially change the report, while the loss by "spreaders" is increased and the count delayed.

* The lines of highest efficiency on a working basis would seem to rest on a 48 hour incubation at 37° C. and a 5 day incubation at 21° C. It would seem advisable to recognize as standard both of these methods of incubation. (Extract from 1908 Report of American Public Health Association.)

To secure saturation of the atmosphere the incubator should be made with a shallow depression over the whole bottom surface, which may be kept filled with water, or in default of this a large shallow pan of water may be kept on one of the lower shelves.

COUNTING.

Expression of Result.—Since minor differences in milk counts are within the working error of the methods and are of no significance in practice, the following scale has been adopted for recording results of market milk examinations:

Counts below 100,000 are distinguished by ten thousands.

Counts between 100,000 and 500,000 are distinguished by fifty thousands.

Counts between 500,000 and 1,000,000 are distinguished by hundred thousands.

Counts between 1,000,000 and 2,000,000 are distinguished by two hundred thousands.

Counts between 2,000,000 and 5,000,000 are distinguished by five hundred thousands.

Counts above 5,000,000 are distinguished by millions.

Therefore only the following figures are used in reporting:

Below	10,000	Above	250,000	Above	1,400,000
Above	10,000	"	300,000	"	1,600,000
"	20,000	"	350,000	"	1,800,000
"	30,000	"	400,000	"	2,000,000
"	40,000	"	450,000	"	2,500,000
"	50,000	"	500,000	"	3,000,000
"	60,000	"	600,000	"	3,500,000
"	70,000	"	700,000	"	4,000,000
"	80,000	"	800,000	"	4,500,000
"	90,000	"	900,000	"	5,000,000
"	100,000	"	1,000,000	"	6,000,000
"	150,000	"	1,200,000	etc.,	by millions.
"	200,000				

FIG. 65.

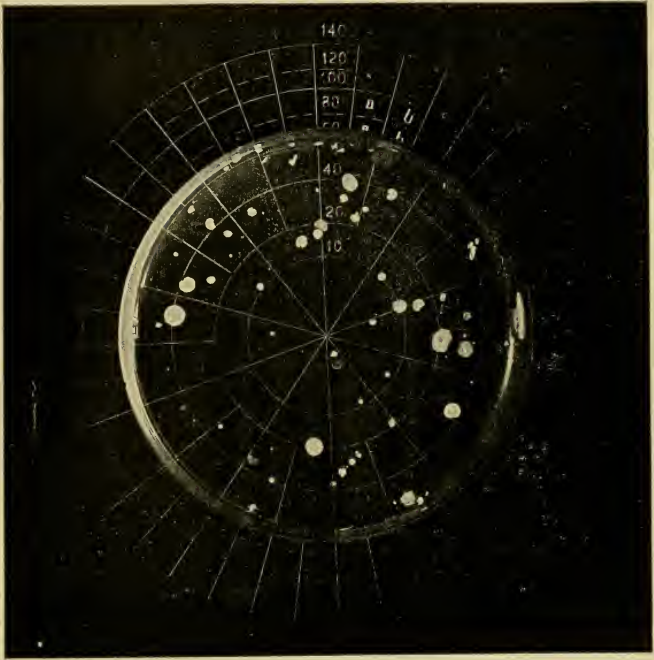

Petri dish containing 1 cubic centimeter of a mixture of milk (1 c.c.) diluted with 499 c.c. of sterilized water and mixed with sterilized agar culture medium. The white spots in the plate are colonies or collections of germs.

Each colony is supposed to represent a single germ at the time the milk was examined. The dish rests on a glass plate lined in white with a black background to facilitate counting the colonies. When the colonies are small and numerous, only those in every other sector of the circle need be counted and the result multiplied by two. In the above plate there are only about 80 plainly visible, but with a common magnifying glass—and one is generally used for counting—about 125 colonies may be seen.

Counts on "certified" or "inspected" milk shall be expressed as closely as the dilution factor will allow.

The whole number of colonies on the plate shall be counted, the practice of counting a fractional part being resorted to only in case of necessity, such as partial spreading.

Fig. 66.

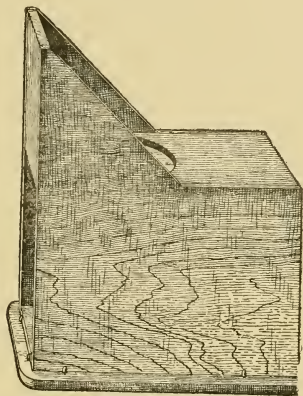

Counting-Box.

Various counting devices have been recommended by different workers. The more simple ones, where the whole plate can be seen at once, are more desirable on account of there being less likelihood of recounting colonies. Colonies too small to be seen with the naked eye or with slight magnification shall not be considered in the count.

CHAPTER XII

MEDIA MAKING AND APPARATUS REQUIRED FOR BACTERIAL ANALYSIS OF MILK

METHODS FOR MAKING MEDIA.

THE Committee on Standard Methods of Bacterial Milk Analysis of the American Public Health Association, Laboratory Section, have recommended that methods of the Committee on Standard Methods of Bacterial and Chemical Water Analysis of the American Public Health Association, Laboratory Section (with two modifications only, noted below), be adopted for official work in counting bacteria in milk; the object being to secure uniformity of results in all laboratories devoted to this task. These methods are by no means to supersede any found valuable by individual investigations for particular purposes, but are urged for adoption *for official counts* of certified, inspected or market milk, and for such investigations as relate directly to comparative counts of different classes of milks, at different ages, etc. Recently (Dec. 31, 1907), they have been recommended also by the Committee on Methods of Identification of Bacterial Species, of the Society of American Bacteriologists, for species work. These methods so far agreed upon are given in the following pages.

NUMERICAL DETERMINATION OF BACTERIA IN MILK.

(From preliminary report of the Committee on Standard methods of Bacterial Milk Analysis.) *

There is no method known by which the exact number of bacteria in a sample of milk may be determined, and even when

* Published in full in "American Journal of Public Hygiene," November, 1907.

the best methods are used, the count is always less than the actual number of bacteria present, for the following reasons:

(a) Many bacteria in process of multiplication are held together by adhesive membranes in pairs, chains or masses. It is for the purpose of separating bacteria thus joined, as well as to obtain an even mixture, that the sample itself and the diluted sample when plating are shaken. This shaking, while it breaks up larger masses and shortens long chains, does not to any great extent break apart the shorter chains, diplococci, etc. Each of these groups of bacteria, when caught in the solid medium, develops as a single colony.

(b) It is impossible to obtain a medium suited to the food requirements of all species or races of bacteria. It has been found by experiment that a medium consisting chiefly of a watery extract of raw meat and peptone, alkaline to litmus and slightly acid to phenolphthalein, will furnish the best food for the greatest number.

(c) These varying forms of minute vegetable life require varying temperatures for their best development. Many forms which will develop at room temperature will not grow at body temperature. Some require a very high temperature for their best growth.

(d) Some bacteria develop in an atmosphere free from oxygen, some only where oxygen is present; many are facultative, *i. e.*, growing under either condition. Bacteria which require an oxygen-free atmosphere do not develop in plates as generally prepared. Bacteria requiring oxygen, if deep in the medium, develop but slowly, as they then obtain free oxygen only by diffusion.

(e) Many forms are slow in developing into visible colonies, some requiring three or four days. On the other hand, in plates grown for several days, many small colonies are obscured in the growth of larger ones.

(f) Each bacterium requires a certain amount of nourishment for development. There are also antagonistic forms which will not develop in close proximity to each other. It therefore

follows that in a crowded plate, *i. e.*, over two hundred colonies, many of the weaker forms will not develop. This is easily proven by making a higher dilution. (See p. 254.)

(*g*) Spreaders* and molds, by their rapid surface growth, merge with other surface colonies and obscure deeper ones.

(*h*) Samples kept in the collecting case at 34° F. for varying periods have shown a tendency to decrease in the number of bacteria which will develop into colonies. Samples kept in dilution water for several hours have shown a marked decrease in the number of bacteria which will develop into colonies.

On account of these reasons strict adherence to standard procedure is of especial importance, since there are so many points where disagreement may result if uniform technique is not followed. (See p. 241.)

SCHEDULE FOR MAKING THE PRINCIPAL ARTIFICIAL MEDIA.

(Arranged by H. W. Hill in accordance with recommendations of the committee on standard methods: A. P. H. A.)

Plain nutrient agar; plain nutrient gelatin; plain nutrient broth; and their modifications (*i. e.*, glycerine agar, plain dextrose agar, muscle-sugar-free dextrose (lactose, maltose, etc.) agar; muscle-sugar-free dextrose (maltose, etc.) litmus agar; glycerine broth; plain dextrose broth; sugar-free broth; muscle-sugar-free dextrose (maltose, etc.) broth; muscle-sugar-free dextrose (maltose, etc.) litmus broth, and other similar combinations, may all be made by these methods.

* "Spreaders" are, properly, intensely vigorous and motile bacteria; these tend to travel over the surface of the agar, instead of remaining within the bounds of a definite colony. But any surface colony may be spread over the surface of a plate, if water, separated from the medium, condenses on the agar, or drops down from condensation on the cover of the Petri dish. The use of earthenware (or "porous") tops for Petri dishes, in place of glass, excludes very largely spreading from this cause, reducing the total of plates spoiled by spreading from nearly 40% to less than 3%.

STEPS COMMON TO ALL VARIETIES.

1. Infuse finely chopped lean round steak (beef) free from fat, gristle, bone, etc., in cold water—proportions 1 gram muscular tissue to 1 c.c. (or gram) of distilled water; weigh container and contents; leave covered in ice-chest for 24 hours. (Example: 1000 grams meat with 1000 grains (or c.c.) water).

2. Weigh container and contents, adding water to make up any loss by evaporation; (*i. e.*, the meat plus the water should weigh 2000 grams); filter through canton flannel, squeezing the successive small portions of the meat left on filter; the filtrate should weigh (or measure) the same amount as the water added in No. 1. If less, squeeze the meat more thoroughly; if more, reject the surplus.

3. Add to the filtrate (known as "1 to 1 meat infusion") 2% by weight of dried commercial "peptone" (Witte's), *i. e.*, 20 grams. (Note: Commercial "peptones" are really largely albumose.)

4. Heat over water bath until peptone is dissolved. The "1 to 1 meat infusion plus peptone" should not be allowed to rise above 50° C. during this process; restore loss by evaporation, *i. e.*, by weighing and restoring to original weight (1000 grams) by addition of water.

STEPS WHICH DIFFERENTIATE THE DIFFERENT MEDIA FROM EACH OTHER.

5. (a) Plain nutrient broth: Add to "1 to 1 meat infusion + peptone" (say 1,000 grams or c.c.) an equal quantity of water, *i. e.*, to make 2,000 grams or c.c. For glycerine broth, add also glycerine by volume to make 5% of the total mixture (*i. e.*, 100 c.c.); for plain dextrose (or maltose, lactose, etc.) broth, add similarly dextrose (or maltose, lactose, etc.) to make 1% by weight of the total mixture (*i. e.*, 20 grams).

(b) Plain nutrient agar: Add to "1 to 1 meat infusion + peptone" (*i. e.*, 1,000 grams or c.c.) an equal quantity of "agar jelly" (*i. e.*, 1,000 grams), hot or cold, prepared by dissolving thread agar (30 grams) in water (to make 1,000 c.c.) by boiling to make a 3% solution (for milk work, 2%), which jellies on cooling. For glycerine agar, plain dextrose, etc., agar, add constituents as under broth. (Note: Plain nutrient agar, made as here directed, except that the percentage of agar in the finished medium is 1% instead of 1½%, and the reaction 1.5% acid instead of 1% acid, is the official count medium recommended by the Committee on Standard Methods of Bacterial Milk Analysis.)

(c) Plain nutrient gelatin: Add to "1 to 1 meat infusion + peptone" (*i. e.*, 1,000 grams or c.c.) an equal quantity of "gelatin jelly," hot or cold (prepared by dissolving sheet gelatin 200 grams in water (to make 1,000 c.c.), heated not above 40° C., to make a 20% solution, which jellies on cooling. For glycerine gelatin and plain dextrose, etc., gelatin, add constituents as under broth.

(d) For all media which should be muscle-sugar-free (either for use as strictly sugar-free media, *i. e.*, as indol broth, or to get rid of all muscle sugar first, in order to add exact quantities of other sugars, adjust the "1 to 1 meat infusion + peptone" to the 1.5% (normal) acid point, as indicated below, warm to 37° C. and inoculate with a vigorous 24 hours culture of *B. coli* in plain broth. Set in incubator at 37° C. for 12 hours (*i. e.*, over night). In this time all the sugar should be disintegrated by the bacillus. Restore any loss by evaporation. Then proceed as under plain nutrient broth, etc., according to the medium desired. (Note: Litmus solution, as described below, or azolitmin,* 2% solution, 1% of the total mixture, may be added to any medium, as desired, at Step 5.)

Note: A test for the presence of sugar may be made as follows:—Fill a fermentation tube with the medium to be tested (after

* This may be bought of makers of biological products.

neutralizing it). Autoclave: when cool, inoculate with a pure culture of *B. coli* and incubate 24 hours at 37° C. If gas collects in the closed arm as the result of growth, a considerable quantity of sugar is still present. If no gas collects, but a growth occurs in the closed arm, a trace of sugar is still present. If the closed arm remains free of growth, all the sugar has been removed.

FURTHER STEPS COMMON TO ALL MEDIA,

6. Adjust to the phenolphthalein 1.5% (normal) acid point (except that broths containing added sugars should be adjusted to the phenolphthalein neutral point). See below.

7. Heat over boiling water for 30 minutes (*i. e.*, the medium itself should be at or about 100° C. for just 30 minutes).

8. Restore loss by evaporation to double original weight of filtrate (Step 2; *i. e.*, to 2,000 grams); check and, if necessary, adjust reaction.

9. Boil over a free flame for just five minutes: counting the five minutes from the beginning of actual boiling. Stir constantly to prevent burning, especially in making nutrient gelatin of any variety.

10. Restore loss by evaporation; check and adjust reaction.

11. Filter, tube, and sterilize.

Note: In all cases, the weight of the medium before filtering, *i. e.*, at the completion of Step 10, should be double the weight of the filtrate obtained in Step 2.

Note: About 5 c.c. of agar, gelatin or liquid media should be placed in each test tube, except that for all media to be used in plating, 10 c.c.'s (exactly) should be used.

Note: The Committee recommends alternatively, the addition of sugars and litmus just before tubing and sterilization in Step 11, instead of in Step 5 as above.

Note: All media should be kept for use in a dark, cool, dust-free place, *i. e.*, a refrigerator or ice-chest.

Fig. 67.

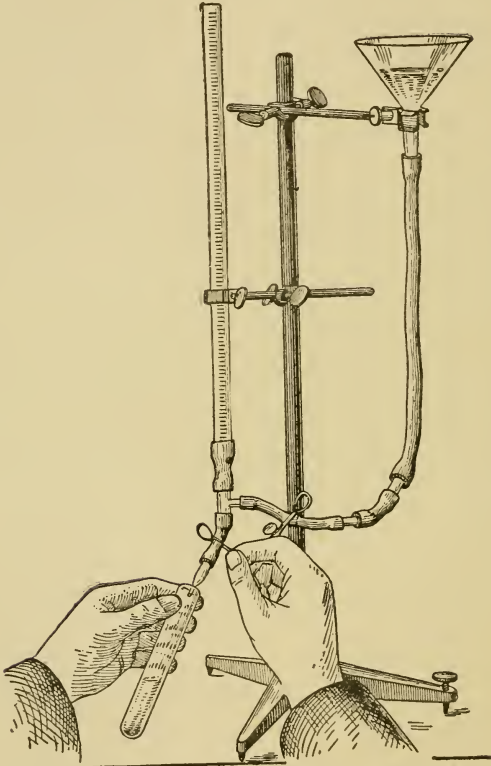

Filling test tubes with a measured amount of culture medium.
(After Conn.)

Note: These methods are those of the Committee on Standard Methods of Water Analysis of the American Public Health Association, except as follows:

1st. They include several media not mentioned in the schedule of the Committee.

2nd. For making gelatin, the water is added with the sheet gelatin at Step 5 (c) above, instead of adding the water at Step 1 and the sheet gelatin at Step 5, as in the Committee schedule.

3rd. In Step 4, the Committee specifies 60° C. as the limit for temperature in dissolving peptone.

4th. The operations are described in somewhat greater detail. None of these four changes are of moment except as contributing to simplicity and uniformity of technique.

5th. The adjustment of reaction is made to precede, instead of, as in the Committee schedule, follow, the 30 minutes heating on the water bath.

6th. The period of boiling over free flame is given as 5 minutes instead of the 2 minutes in the Committee schedule.

The changes 5 and 6 were suggested to the Committee and accepted by them for reasons given in the writer's article (*Journ. Infec. Diseases*, Supplement II, p. 223), but since no revision of the report has since been made, the schedule appears uncorrected in existing reports.

Milk Medium.—Plain, fresh, rich milk (preferably "certified"), skimmed by centrifugalization, of a reaction not over 1.5% (normal) acid, is to be brought to 1% (normal) acid, tubed and sterilized.

Litmus milk is prepared by adding to the above, before tubing, 1% of the litmus solution described below (or of a 2% aqueous azolitmin solution, when this can be procured of the proper grade.)

Artificial Milk.—(Lactose Nutrose Solution).—Owing to the fact that milk has a varying acidity and to the inconvenience of securing separator milk, which, when secured, is not wholly free from fat, the following is offered as a substitute: Nutrose (Sodium—phosphate—casein), 2.6 grams; lactose, 1.1 grams; water (distilled), 100 c.c. Heat slightly to dissolve the nutrose. *Do not boil.*

After heating for about 15 minutes, filter through cotton, tube and autoclave at 15 lbs. for 15 minutes.

(This substitute was suggested by H. W. Hill in 1898, worked out by A. J. Chesley, and adopted in the Minnesota State Board of Health Laboratories, 1908.)

Potato Medium.—Good sized, plump potatoes, free from bad spots, are well washed and peeled; cylinders of a size to fit the test tube are cut from them with a cork borer of appropriate size to slip into the test tubes; the cylinders are cut diagonally across and the resulting half-cylinders washed over night in running water; they are then dropped, large end down, one half-cylinder to a tube, into test tubes containing wads of cotton, saturated with water, pushed to the bottom of the tube, the potato resting on the wet cotton; the tubes are then plugged and sterilized. Note: Potato remaining sharply acid to litmus paper after the over-night washing, should be rejected.

Nitrate Broth.—Dissolve 1 gram peptone in one litre of water; add 2 grams nitrite-free potassium nitrate; adjust to 1% (normal) acid to phenolphthalein, tube and sterilize.

Löffler's Blood Serum.—To glycerine dextrose broth 3 parts, add 1 part fresh serum (obtained by collecting cow, pig, horse, etc., blood in a clean pail and allowing it to stand in cold storage for 24 hours; the blood clots, the clot shrinks, and with care, the straw-colored serum or liquid part may be drawn off with a syphon or large pipette). Adjust reaction to 0.8% acid, and coagulate thus: slope tubes to get a large surface, being careful not to wet plugs, in an autoclave, which does not leak steam *at all*. Run up *slowly* to 100° C., taking great care that all the air is driven out by the steam. After maintaining the temperature at 100° C. for 20 minutes, close outlet cock and run up slowly to 15 lbs. pressure, still preventing even momentary escape of steam even from one safety valve. Hold at 15 lbs. for 15 minutes, then cut off steam or gas supply and cool to room temperature before opening. Open

pet cock first a little at a time, until pressure inside and out is equal. This process should not take more than one to one and one-half hours.

The general principal of the above was devised in the Minn. State Board of Health Laboratories, but is applied there to chloroformed serum, and requires about four times as long. As given, the method was devised in the Boston Board of Health Bacteriological Laboratory, and is for fresh serum only.

Test for Indol.—Grow the bacteria which it is desired to test for 10 days in muscle-sugar-free broth (“indol broth”). Add 10 drops of sulphuric acid and 1 c.c. of an aqueous solution of sodium nitrite (1 in 10,000); a pink color developing at once or within half an hour, especially on warming gently to 50° C., indicates presence of indol. Certain bacteria produce nitrites. If such produce indol also (as in the case of the cholera spirillum (*microspira comma*), sulphuric acid, added as described, produces the color without further addition of nitrite. This is called the cholera red reaction.

Test for Formation of Nitrites from Nitrates.—Grow the bacteria for 5 days in “nitrate broth.” Add to the culture 2 c.c. of freshly made mixture of the following solutions: (a) naphylamine, 1% aqueous solution; (b) sulphanilic acid, 3% solution in dilute acetic acid. A pink color shows presence of nitrite. Nitrite is absorbed from the air, and in laboratory air much nitrite is usually present; hence care should be taken at every stage to avoid air-exposure so far as possible, and uninoculated tubes of the nitrate medium, exposed to the same conditions as those inoculated, should be tested at the same time as a control.

Litmus Solution.—Take 200 to 500 grams of litmus cubes (chalk saturated in crude litmus and dried). Pulverize in mortar; wash all blue out of chalk with water on a filter paper. Evaporate water to dryness. Pulverize residue and wash on filter with alcohol (95%) to extract the red portion. When the alcohol passing through the litmus comes away colorless (8 or 9 litres of al-

cohol are often required), dry residue, weigh and dissolve in water in proportions to make a 5% solution. Add 1/5 of 1% chloroform to the solution to preserve it. Of this solution, 10 to 15 c.c. per litre of media should give a good blue tint. Note: On autoclaving, most litmus media lose color entirely. The color returns on cooling and exposure to air. (Method of Minn. State Board of Health Laboratories).

COHN'S SOLUTION.

	Per cent.
Distilled water, containing	
Tribasic calcium phosphate.....	0.05
Magnesium sulphate.....	0.50
Acid potassium phosphate	0.50
Ammonium tartrate.....	1.00

Sterilize by intermittent method in free steam.

USCHINSKY'S SOLUTION.

	Per cent.
Distilled water containing	
Calcium chloride.....	.01
Magnesium sulphate.....	.02
Acid potassium phosphate.....	.10
Sodium chloride.....	.50
Ammonium lactate.....	1.00
Asparagin.....	.34
Glycerine.....	4.00

Sterilize by intermittent method of free steam.

SILICATE JELLY.

Solution (a) distilled water, containing—	Per cent..
Calcium chloride.....	.02
Magnesium sulphate.....	.10
Ammonium sulphate.....	.80
Solution (b) distilled water, containing—	
Potassium phosphate.....	.2
Sodium carbonate.....	1.2
Solution (c) distilled water, containing 3.4% silicic acid.	

Pour about 5-10 c.c. of (c) into a Petri dish: add, with stirring, a mixture of equal parts of (a) and (b). Sterilize intermittently in free steam; streak upon the jelly thus prepared the organisms it is desired to grow.

USES OF MEDIA.

The chief media in ordinary use are valuable because each elicits certain characteristics of bacteria which, taken together, permit the recognition of the identity of the bacteria. The methods of

preparing media generally accepted are given on p. 263. The chief uses to which they are put are described below.

Plain nutrient agar—remains solid at 37° C.— 40° C.; melts at 100° C: solidifies again about 40° C. Used for plating (in 10 c.c. quantities) and for characteristics of growth (in 5 c.c. quantities; tubes are slanted while cooling to secure a wide long surface of jelly). The sizes, shapes and staining of bacteria after growth on this medium for 24 hours are taken as the standards in describing their morphology. Chromogenic and fluorescent bacteria show their pigments well on this medium. For plates to be incubated at 37° C. porous tops should be used, to lessen “spreading.”

Fig. 68.

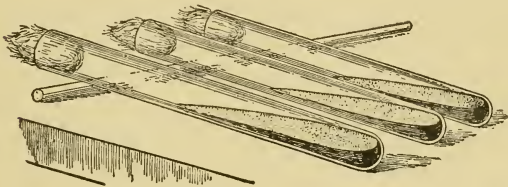

Hardening Agar Slants. (After Conn.)

Plain nutrient gelatin—if well made, remains solid at 24° — 25° C.; melts just above this point; solidifies on cooling to 24° — 25° C. Used for plating (in 10 c.c. quantities) and for characteristics of growth (in 5 c.c. quantities; tubes are vertical while cooling, and inoculations are made by thrusting a straight needle—not a looped needle—half way to the bottom of the jelly along the central axis of the tube—thus making a “stab”). Many bacteria liquefy gelatin, through the action of a soluble digestive ferment (or enzyme) secreted by them; many do not liquefy it, hence a point of distinction between species is yielded; the shape, size and rapidity of development of the

liquefaction further assists in recognition. Plates, to remain solid, must be incubated at about 22° C. The great objections to gelatin for plates are the difficulty of maintaining the temperature at 22° C., and the liquefaction due to some species, which usually quickly destroys the chief value of a plating medium—its solidity.

Modifications of agar and gelatin media—the sugars are added chiefly to elicit gas formation (best tested in stabs); litmus to indicate changes in reaction; glycerine, because certain bacteria are believed to grow better in its presence; milk for a similar reason.

Plain nutrient broth—used chiefly for characteristics of growth on liquids and to elicit the typical arrangements of cells when growing freely (*i. e.*, chains, clusters, etc.); also for motility, which develops better in liquids than on solids. Tube 5 c.c. in a test tube; in fermentation tubes, use enough to half fill bulb and completely fill closed arm. The modifications (with sugars, litmus, glycerine, etc.) are made for the reasons given under agar and gelatin. Gas formation is best determined quantitatively and qualitatively, by the use of sugar broths in fermentation tubes.

Potato—for gross characteristics of growth.

Milk—for the detection of coagulation of milk, the subsequent solution of the clot, and other evidences of digestive action. Milk is too full of casein particles, fat and albumin to yield good smear preparations for morphological study as a rule. Combined with litmus, acid or alkali formation can be determined, and changes in reaction noted. Litmus milk often becomes decolorized by bacterial absorption of the oxygen necessary to its coloration.

Serum—apart from characteristics of growth and morphology, serum becomes translucent and later liquified under the action of certain bacteria. The morphology of bacteria growing on this medium is readily determined also, and is sometimes characteristic.

Starch jelly—chiefly used for appreciation of diastatic action.

Silicate jelly : *Cohn's and Uschinky's solutions*—are chiefly used in the study of certain bacteria which grow best or exclusively on such media ; and in the search for synthetic media applicable to all bacteria.

TECHNIQUE OF HANGING DROP.

Secure to a slide with thick Canada balsam, softened by heat, a ring of glass, celluloid, rubber, metal, etc., about $\frac{3}{4}$ " diameter, $\frac{1}{16}$ " wide, $\frac{1}{8}$ " thick. Vaseline the free edge of the ring. Mix on a coverslip one drop of sterile water with one drop of the material to be examined, as directed for staining, but instead of drying, turn the coverslip down over the ring, so that it sticks to the vaselined edge with the drop downward within the ring. Focusing carefully on the drop from above, the bacteria, etc., in the drop will be seen.

TECHNIQUE OF SIMPLE STAIN.

Place on a clean slide with an inoculating needle one drop of sterile water. Mix with this one drop of a broth culture, of milk, of water or other liquid containing bacteria ; dry over a flame gently (without boiling), spreading with the needle from time to time to secure a smooth, even "smear." When dry, and still hot, place two or three drops of 95% alcohol on the smear and allow it to dry. This alcohol treatment may be omitted in the case of milk, and should be omitted when the material to be examined is from a culture on solid media (agar, gelatin, potato, etc.).

Stain with aqueous fuchsin, aqueous methylene blue, Löffler's methylene blue or other simple stains (*i. e.*, not combined with a mordant), thus: flood the smear with the dye, wash off in water thoroughly, and dry. Simple ("aqueous") stains consist of the dry stain or dye, 1 part, alcohol 10 parts, water 100 parts.

Note: Young cultures stain well with methylene blue, and peculiarities of staining are best shown with this stain, such as polar granules, vacuoles, metachromatic granules, etc. The intensity with which this stain colors the bacteria is important, certain species staining faintly, others deeply.

In old cultures, methylene blue stains only the more vigorous survivors: those which have died (as a result of auto-intoxication, etc., not those killed artificially by heat) losing the power to stain well with this dye; with aqueous fuchsin, the tendency with young cultures is to overstain; with old cultures, the degenerate forms stain, as well as those not degenerate.

TECHNIQUE OF ZIEHL-NIELSEN STAIN FOR TUBERCLE BACILLI AND SPORES.

For tubercle bacilli: Prepare a smear of the suspected material; cover the smear with an excess of the Ziehl-Nielsen stain; heat five minutes, without boiling, however. Wash in water; decolorize until a faint pink only remains with acid alcohol (HCl 5 parts, alcohol 100 parts.) Wash and counter-stain with methylene blue. Wash and mount. The tubercle bacilli are seen red in a blue field. Since bacilli not unlike the tubercle bacillus in appearance, and staining by the same method, are found at times on certain grasses, hay, etc., and in butter, etc., conclusive proof that tubercle bacilli are present in a given farm product cannot be had from the staining reaction alone, but requires confirmation from careful study of the effects upon a guinea-pig of inoculation with the bacterium in question.

For spores.—Proceed as above, but in decolorizing use alcohol 1 part, in water 3 parts, instead of acid alcohol.

GRAM'S STAIN.

Prepare a saturated solution of gentian violet in alcohol and keep as a stock solution.

Prepare fresh each time anilin oil water thus:

Anilin oil	1 c.c.
Water	50 c.c.

Shake violently; filter repeatedly until clear. Mix three parts of the anilin oil water with one part of the gentian violet solution—thus making “anilin-oil-gentian-violet.”

Process.

1. Prepare smears as usual.
2. Stain in anilin-oil-gentian-violet, 1½ minutes.
3. Wash in water; smear now deep violet.
4. Wash with Gram's solution (iodin 1, potassium iodide 2, water 300); smear now purple black.
5. Decolorize with successive small quantities of 95% alcohol until no more color comes away in the alcohol.
6. Counterstain with Bismark brown (5% aqueous solution).
7. Wash, dry and mount for examination.

This rather important stain depends for its differential value on the fact that whereas *all* species of bacteria, stained by anilin-oil-gentian-violet, may be decolorized with alcohol, *certain* species, if iodine be used to fix the stain, become undecolorizable, while others lose the stain as readily after the iodine treatment as without it.

EXAMINATIONS FOR B. COLI IN MILK.

This examination, like that for pus and for streptococci, has not yet had its true value or significance determined. Its advocate, Stokes, finds a relation between the frequency with which it is found and the number of bacteria present—*i. e.*, high count milk is much more likely to yield colon bacilli than low count milk. It is unlikely that this test as a rule indicates more than the admission of manure to the milk in unusual proportions. Stokes' method is as follows:

Ox bile is collected from slaughter houses; 1% of lactose added; this medium is placed in fermentation tubes and sterilized. For the test, 1/1000 c.c. of the milk in question is added and the tube incubated at 37° C. for 72 hours; if more than 15% of the length of the closed arm of the fermentation tube is occupied by gas at the end of this time, plates are made from the fluid, and colonies isolated and tested as for *B. coli*.

LIST OF APPARATUS REQUIRED FOR A SIMPLE LABORATORY FOR BACTERIAL WORK RELATED TO MILK.

- Work table**, of wood, firm and smooth, not painted or varnished, but oiled or vaselined (hot) or treated with aniline black mixture; well lighted by a north window: 40 inches above floor for "stand up" work, 30 inches for "sit down" work.
- Water supply**: Preferably hot and cold, emptying into a large sink (about 3' x 1'-1' x $\frac{1}{2}$ "); a much smaller sink, and a supply consisting of a barrel with faucet, or even a large chamber pitcher, may be used.
- Waste pipes** of ordinary plumbing may be used: or wooden rain-troughs (eave pipes) may be set below the sink outlet and used to conduct the waste to an appropriate outlet.
- Gas supply**. Gas-pipes, fitted with simply keyed gas outlets for attachment of rubber hose for Bunsen burners and gas stoves of one and two plates may be used; or alcohol lamps of the Barthel type may replace the Bunsen burners; of the Glogau type, the gas stoves.
- Sterilizers**. A very satisfactory hot-air oven for empty glassware of all descriptions consists of an ordinary gas stove oven, used on a two-plate gas stove or on a Glogau type alcohol stove; even the oven of an ordinary cook range may be used.
- Arnold sterilizers for media**, contained in flasks, test tubes, etc., for free steam; these may be obtained of tin or of copper; or a good home-made substitute may be constructed by attaching to the lip of a deep tin or agate four-quart pan (to contain the boiling water) a tin cylinder with vertical sides, a fairly tight cover and a perforated bottom.

the steam rising through the latter. If possible, however, an autoclave should be obtained; one type can be heated directly by gas, making its own steam; the same can be obtained, modified for attachment directly to steam pipes carrying steam under pressure. For laboratory purposes the Bramhall Deane (New York) autoclave (2B) is highly to be recommended.

Sterilization in the Arnold sterilizer must be done on three successive days with full steam for twenty minutes each day, the media being kept at room temperature in the intervals between steaming. With the autoclave a single sterilization at fifteen pounds pressure (120° C.) is sufficient.

Rubber tubing, white, of a proper size to fit snugly both gas outlets and Bunsen burners.

Funnels, $\frac{1}{2}$ or 1 liter, agate ware, or copper tinned inside, or glass.

Granite or agate ware, "double boiler" with cover, capacity of inside pan at least four liters. Large granite or agate ware spoons.

Wire baskets for test tubes, 7" long, 5" wide, 5" deep, smooth wrapped corners and edges, no solder.

Petri dishes, with porous tops, 4" diameter, $\frac{3}{8}$ " to $\frac{1}{2}$ " deep.

Tumblers, to be used with cotton in bottom for holding test tubes; or wire test tube racks, Harvard pattern.

Funnels, 2", 4", 6" diameter for filtering stains, etc.

Filter paper—(Schleicher & Schüll 597) in large squares.

Lens paper—Japanese.

Cylinder graduates—25 c.c., 50 c.c., 100 c.c., 500 c.c., 1000 c.c.

Fermentation tubes, Smith pattern, or Hill pattern.

Thermometers, for incubator; for oven; for autoclave? for ordinary purposes, say 6, ranging from 30° C. to 110° C., and 2, ranging from 100° C. to 300° C.

Cork borer and sharpener.

Test tube brushes, with sponge at end, bristles at side.

Pinch-cocks for rubber tubing.

Blast lamp for blowing glass, bending tubes, etc.

Stain bottles (i. e., rubber nipples pipette bottles, 1 to 2 oz. capacity).

Absorbent cotton, for filtering.

Non-absorbent cotton. First grade cotton, for plugging test tubes, etc.; second grade, for tumblers, etc.

Fuchsin, basic, Grüber 10 grams

Immersion oil.

Methylene blue " 10 "

Glycerine.

Carbolic acid -phenol -1st grade 1 lb.

Canada balsam.

Aniline oil Grüber 1 oz.

Thread agar—best.

Gentian violet " 10 grams

Gold label gelatin in sheets—10 lbs.

Iodine 10 "

Hydrochloric acid 1 lb.

Potassium iodide 1 oz.

Sodium hydrate 1 lb.

Alcohol 96% ethyl 1 gal.

Xylol for cleaning lenses 2 oz.

Test tubes: 6" x $\frac{3}{8}$ ", without lip, of good "non-crystallizable glass" (Boston Board of Health pattern); they should be plugged with cotton and sterilized in hot air as below. A few test tubes should be graduated and marked at 9. c.c. capacity and kept for dilution purposes.

Pipettes: 1 c.c. mark, discharge pipettes, about 10—11 inches long, 3 mm. inside diameter, are the best. These may be enclosed in long tubes one in each, of glass, sealed at one end, stoppered with cotton at the other; or the point may rest on a cotton wad at the bottom of a test tube, the mouth of the test tube being plugged with cotton round the stem, a small cotton plug being inserted into the mouth of the pipette

also; or they may be placed loose in cylindrical (better square) copper or tin boxes (with lapped or folded, not soldered seams) a little longer than the pipette; or they may be simply wrapped individually in filter paper. However prepared, they should be sterilized in the hot air oven for one hour at 160° C. (or 200° C. for 30 minutes), or until a wad of cotton placed beside them as an indicator becomes slightly browned by the heat.

Flasks (preferably of the Erlenmeyer pattern) of good Bohemian glass with wide necks and flat thin bottoms, 1 liter capacity. Plug with cotton and sterilize in hot air.

Bottles—S oz. Blake's, square, wide mouthed, marked (by a file, or diamond, but best with hydrofluoric acid) at 99 c.c. capacity for dilution water. Plug with cotton and sterilize in hot air.

Petri dishes—4" (10 cm.) glass bottoms, with porous covers to match. Wrap in soft paper or place in sets of 10 in a covered cardboard box for sterilization by dry heat.

Incubator. If gas is available, a Koch safety burner and Lautenschlager ether-mercury gas regulator may be used. Fair results have been obtained where gas was not available by using an ordinary chicken incubator carefully regulated and watched daily.

Counting apparatus. That of the International Instrument Co. (Boston Board of Health pattern) or Stewart's counter, are good. A home-made one quite efficient for the finest work may be made from a child's school slate, on which is scratched a four-inch circle, divided by four cross lines into eighths; a box about 4½ to 5 inches square, about 4 inches high, without a bottom, to rest on the slate over the square, and having one side (to face the window) glass, the top perforated by a hole 3½" in diameter, on which a 4" reading glass rests; the height of the box to correspond with the practical focus of the lens, which may be determined readily beforehand (*i. e.*, the distance which the lens should be from the object examined in order to give a clear magnified image to the observer with his eye at a convenient distance from the lens). To count a plate, place the plate upon the circle marked on the slate, centering it carefully; remove the cover; place the box over it, with the glass front towards the window and the reading lens over the circular opening in the top: and count all the colonies visible, using the divisions of the circle merely as an aid to prevent recounting the same colony. It is well to number the divisions and always to begin counting at division No. 1, in order that the same division should not be counted twice. Of course, once the counting has begun, the plate must not be permitted to shift on the lines even to a very slight extent.

Microscope. A microscope is not essential to bacterial work on milk, so long as species differentiation is not attempted, and much valuable information bearing on clean milk can be demonstrated by a beginner to himself through methods hereinbefore described without ever seeing an isolated bacterial cell—in other words, by dealing wholly with mass growths of bacteria, cultures, colonies, etc. If a microscope is desired, however, a good instrument should be bought from standard makers, American or foreign—a monocular tube, with fine adjustment, substage condenser, iris diaphragm and oil-immersion lens covering the essentials. A combination of lenses giving great satisfaction in practice consists of: objectives, ½" oil immersion; ⅜" "dry," and ¼" "dry"; and oculars Nos. 1 and 4 or equivalents. A triple nosepiece is not necessary, although a great convenience; a mechanical stage is needed only for refined work. A satisfactory instrument for all ordinary work may be had at from \$70 to \$100. Books describing the care and use of the microscope may be had, notably by Gage and by Wright (Gage—"The Microscope," Comstock Publishing Co., Ithaca N. Y.; Wright—"Principles of Microscopy," MacMillan Co., New York).

CHAPTER XIII

CLASSIFICATION AND IDENTIFICATION OF BACTERIA—GLOSSARY—ADJUSTMENT OF REACTION OF MEDIA

MIGULA-CHESTER CLASSIFICATION.

(ARRANGED BY H. W. HILL.)

(Giving the families and genera by name; and the number of species in each genus, as described in Chester's Manual.)

	BACTERIA.		
Branched.			
	MYCOBACTERIACEÆ		
growth axis filamentous.....	Streptothrix	18	Species
growth axis not filamentous.....	Mycobacterium	19	"
Not branched			
growth axis filamentous			
cells sheathed	CHLAMYDOBACTERIACEÆ		
sulphur granules.....	Thiothrix	1	"
no sulphur granules			
filaments pseudo-branched.....	Cladothrix	10	"
filaments not pseudo-branched			
cell-division in 1 plane.....	Leptothrix	6	"
cell-division in 3 planes			
sheath delicate.....	Phragmidiothrix	1	"
sheath well-developed.....	Crenothrix	1	"
cells not sheathed			
	BEGGIATOACEÆ		
growth axis not filamentous	Beggiatoa	4	"
growth axis > transverse axis			

NOTE—Families in capitals; genera in small letters.

growth axis spiral	SPIRILLACEÆ		
cell flexile	Spirochaeta	5	Species
cell not flexile			
flagellate			
three or less, polar	Microspira	20	"
bundle, polar	Spirillum	13	"
not flagellate	Spirosoma	5	"
growth axis not spiral	BACTERIACEÆ		
flagellate			
peritrichic	Bacillus	275	"
polar	Pseudomonas	47	"
not flagellate	Bacterium	216	"
growth axis not > transverse axis	COCCACEÆ		
flagellate			
cell-div. in 2 planes	Planococcus	3	"
cell-div. in 3 planes	Planosarcina	3	"
not flagellate			
cell-div. in 1 plane	Streptococcus	36	"
cell-div. in 2 planes	Micrococcus	91	"
cell-div. in 3 planes	Sarcina	14	"

SCHEME FOR EXAMINATION OF PURE BACTERIAL CULTURES, FOR IDENTIFICATION OF SPECIES

(Adopted by the Society of American Bacteriologists, Dec. 31, '07: Committee on Identification of Species, Chester, Gorham and E. T. Smith.)

I. MORPHOLOGY.

1. **Vegetative Cells.**—Medium used; temperature; age in days. Form, *round, short rods, long rods, short chains, long chains, filaments, commas, short spirals, long spirals, clostridium, cuncate, clavate, curved*. Limits of size. Size of majority. Ends, *rounded, truncate, concave*.
Agar Hanging-Block.—Orientation (grouping). Chains (No. of elements). *Short chains, long chains*. Orientation of Chains, *parallel, irregular*.
2. **Sporangia.**—Medium used; temperature; age in days. Form, *elliptical, short rods, spindle, clavate, drumsticks*. Limits of Size. Size of Majority.
Agar Hanging-Block.—Orientation (grouping). Chains (No. of elements). Orientation of Chains, *parallel, irregular*.
Location of Endospores, *central, polar*.
3. **Endospores.**—Form, *round, elliptical, elongated*. Limits of Size. Size of Majority. Wall, *thick, thin*. Sporangium wall, *adherent, not adherent*. Germination, *equatorial, oblique, polar, bipolar, by stretching*.
4. **Flagella.**—No.; Attachment, *polar, bipolar, peritrichiate*. How Stained.
5. **Capsules.**—Present on.
6. **Zoogloea.**—Pseudozoogloea.
7. **Involution Forms.**—On; in.... days at....°C.

8. **Staining Reactions.**—1:10 watery fuchsin, gentian violet, carbol fuchsin, Loeffler's alkaline methylene blue. Special Stains: Gram; Glycogen; Fat; Acid fast; Neisser.

II. CULTURAL FEATURES.

1. **Agar Stroke.**—Growth, *invisible, scanty, moderate, abundant*. Form of growth, *filiform, echinulate, beaded, spreading, plumose, arborescent, rhizoid*. Elevation of growth, *flat, effuse, raised, convex*. Lustre, *glistening, dull, cretaceous*. Topography, *smooth, contoured, rugose, verrucose*. Optical Characters, *opaque, translucent, opalescent, iridescent*. Chromogenesis. Odor, *absent, decided, resembling*..... Consistency, *slimy, butyrous, viscid, membranous, coriaceous, brittle*. Medium, *grayed, browned, reddened, blued, greened*.
2. **Potato.**—Growth, *scanty, moderate, abundant, transient, persistent*. Form of growth, *filiform, echinulate, beaded, spreading, plumose, arborescent, rhizoid*. Elevation of growth, *flat, effuse, raised, convex*. Lustre, *glistening, dull, cretaceous*. Topography, *smooth, contoured, rugose, verrucose*. Chromogenesis. Pigment in water, *insoluble, soluble*; other solvents. Odor, *absent, decided, resembling*.. Consistency, *slimy, butyrous, viscid, membranous, coriaceous, brittle*. Medium, *grayed, browned, reddened, blued, greened*.
3. **Loeffler's Blood Serum.**—Stroke, *invisible, scanty, moderate, abundant*. Form of growth, *filiform, echinulate, beaded, spreading, plumose, arborescent, rhizoid*. Elevation of growth, *flat, effuse, raised, convex*. Lustre, *glistening, dull, cretaceous*. Topography, *smooth, contoured, rugose, verrucose*. Chromogenesis. Medium, *grayed, browned, reddened, blued, greened*. Liquefaction begins in....d, complete in....d.
4. **Agar Stab.**—Growth, *uniform, best at top, best at bottom; surface growth scanty, abundant; restricted, wide-spread*. Line of puncture, *filiform, beaded, papillate, villous, plumose, arborescent; liquefaction*.
5. **Gelatin Stab.**—Growth, *uniform, best at top, best at bottom*. Line of puncture, *filiform, beaded, papillate, villous, plumose, arborescent*. Liquefaction, *crateriform, napiform, infundibuliform, saccate, stratiform*; begins in.....d, complete in.....d. Medium, *fluorescent, browned*.
6. **Nutrient Broth.**—Surface growth, *ring, pellicle, flocculent, membranous, none*. Clouding, *slight, moderate, strong; transient, persistent; none; fluid turbid*. Odor, *absent, decided, resembling*.. Sediment, *compact, flocculent, granular, flaky, viscid on agitation, abundant, scant*.
7. **Milk.**—Clearing without coagulation. Coagulation, *prompt, delayed, absent*. Extrusion of whey begins in.....days. Coagulum, *slowly peptonized, rapidly peptonized*. Peptonization begins on.....d, complete on.....d. Reaction, 1d, 2d, 4d, 10d, 20d. Consistency, *slimy, viscid, unchanged*. Medium, *browned, reddened, blued, greened*. Lab ferment, *present, absent*.
8. **Litmus Milk.**—*Acid, alkaline, acid then alkaline, no change*. Prompt reduction, *no reduction, partial slow reduction*.
9. **Gelatin Colonies.**—Growth *slow, rapid*. Form, *punctiform, round, irregular, ameoboid, mycelioid, filamentous, rhizoid*. Elevation, *flat, effuse, raised, convex, pulvinate, crateriform (liquefying)*. Edge, *entire, undulate, lobate, crose, lacerate, fimbriate, filamentous, floccose, curled*. Liquefaction, *cup, saucer, spreading*.

10. **Agar Colonies.**—Growth, *slow, rapid* (temperature). Form, *punctiform, round, irregular, amoeboid, myceloid, filamentous, rhizoid*. Surface *smooth, rough, concentrically ringed, radiate, striate*. Elevation, *flat, effuse, raised, convex, pulvinate, umbonate*. Edge, *entire, undulate, lobate, erose, lacerate, fimbriate, floccose, curled*. Internal structure, *amorphous, finely-, coarsely granular, grumose, filamentous, floccose, curled*.
11. **Starch Jelly.**—Growth, *scanty, copious*. Diastasic action, *absent, feeble, profound*. Medium stained.
12. **Silicate Jelly (Fermi's Solution).**—Growth, *copious, scanty, absent*. Medium stained.
13. **Cohn's Solution.**—Growth, *copious, scanty, absent*. Medium, *fluorescent, non-fluorescent*.
14. **Uschinsky's Solution.**—Growth, *copious, scanty, absent*. Fluid, *viscid, not viscid*.
15. **Sodium Chloride in Bouillon.**—Per cent inhibiting growth.
16. **Growth in Bouillon over Chloroform,** *unrestrained, feeble, absent*.
17. **Nitrogen.**—Obtained from *peptone, asparagin, glycocoll, urca, ammonia salts, nitrogen*.
18. **Best media for long-continued growth.**
19. **Quick tests for differential purposes.**

III. PHYSICAL AND BIOCHEMICAL FEATURES.

1. **Gas Production from Sugar.**—(a) *Amount in percentage of tube length (closed arm of fermentation tube)*. (b) *H/CO₂ formula*. (c) *Acidity by titration, dextrose, saccharose, lactose, maltose, glycerin, mannit*.
2. **Ammonia production,** *feeble, moderate, strong, absent, masked by acids*.
3. **Nitrates in nitrate broth.**—*Reduced, not reduced*. Presence of nitrites; ammonia; presence of nitrates; free nitrogen.
4. **Indol production,** *feeble, moderate, strong*.
5. **Toleration of Acids:** *great, medium, slight. Acids tested*.
6. **Toleration of Na O H:** *great, medium, slight*.
7. **Optimum reaction for growth in bouillon,** stated in terms of Fuller's scale.
8. **Vitality on culture media:** *brief, moderate, long*.
9. **Temperature relations.**—Thermal death point (10 minutes exposure in nutrient broth when this is adapted to growth of organism).....C. Optimum temperature for growth.....C.; or best growth at 15° C., 20° C., 25° C., 30° C., 37° C., 40° C., 50° C., 60° C. Maximum temperature for growth.....C. Minimum temperature for growth.....C.
10. **Killed readily by drying:** resistant to drying.
11. **Per cent. killed by freezing** (salt and crushed ice or liquid air).
12. **Sunlight:** Exposure on ice in thinly sown agar plates: one-half plate covered (time 15 minutes), *sensitive, not sensitive*. Per cent killed.
13. **Acids produced.**
14. **Alkalies produced.**
15. **Alcohols.**
16. **Ferments;** *pepsin, trypsin, diastase, invertase, pectase, cytase, tyrosinase, oxidase, peroxidase, lipase, catalase, glucase, galactase, lab, etc.*
17. **Crystals formed.**
18. **Effect of germicides.**

IV. PATHOGENICITY.

1. **Pathogenic to Animals.**—*Insects, crustaceans, fishes, reptiles, birds, mice, rats, guinea pigs, rabbits, dogs, cats, sheep, goats, cattle, horses, monkeys, man.*
2. **Pathogenic to Plants.**
3. **Toxins, soluble, endotoxins.**
4. **Non-toxin forming.**
5. **Immunity bactericidal.**
6. **Immunity non-bactericidal.**
7. **Loss of virulence on culture media:** *prompt, gradual, not observed*—
in.....months..

GLOSSARY OF BACTERIOLOGICAL TERMS USED IN DESCRIBING AND
IDENTIFYING SPECIES OF BACTERIA.

(Committee on Identification of Species : Soc. Am. Bact.)

- AGAR HANGING BLOCK**, a small block of nutrient agar cut from a poured plate, and placed on a cover-glass, the surface next the glass having been first touched with a loop from a young fluid culture or with a dilution from the same. It is examined upside down, the same as a hanging drop.
- AMEBOID**, assuming various shapes like an ameba.
- AMORPHOUS**, without visible differentiation in structure.
- ARBORESCENT**, a branched, tree-like growth.
- BEADED**, in stab or stroke, disjointed or semi-confluent colonies along the line of inoculation.
- BRIEF**, a few days, a week.
- BRITTLE**, growth dry, friable under the platinum needle.
- BULLATE**, growth rising in convex prominences, like a blistered surface.
- BUTYROUS**, growth of a butter-like consistency.
- CHAINS**,—Short chains, composed of 2 to 8 elements. Long chains, composed of more than 8 elements.
- CILIATE**, having fine, hair-like extensions, like cilia.
- CLAVATE**, club-shaped.
- CLOUDY**, said of fluid cultures which do not contain pseudozoogloecae.
- COAGULATION**, the separation of casein from whey in milk. This may take place quickly or slowly, and as the result either of the formation of an acid or of a lab ferment.
- CONTOURED**, an irregular, smoothly undulating surface, like that of a relief map.
- CONVEX**, surface the segment of a circle, but flattened.
- COPROPHYL**, dung bacteria.
- CORIACEOUS**, growth tough, leathery, not yielding to the platinum needle.
- CRATERIFORM**, round, depressed, due to the liquefaction of the medium.
- CRETACEOUS**, growth opaque and white, chalky.
- CUNEATE**, wedge-shaped.
- CURLED**, composed of parallel chains in wavy strands, as in anthrax colonies..

- DIASTASIC ACTION**, same as **DIASTATIC**, conversion of starch into water-soluble substances by diastase.
- ECHINULATE**, in agar stroke a growth along line of inoculation, with toothed or pointed margins; in stab cultures growth beset with pointed outgrowths.
- EFFUSE**, growth thin, veily, unusually spreading.
- ENTIRE**, smooth, having a margin destitute of teeth or notches.
- EROSE**, border irregularly toothed.
- FILAMENTOUS**, growth composed of long, irregularly placed or interwoven filaments.
- FILIFORM**, in stroke or stab cultures a uniform growth along line of inoculation.
- FIMBRIATE**, border fringed with slender processes, larger than filaments.
- FLOCCOSE**, growth composed of short curved chains, variously oriented.
- FLOCCULENT**, said of fluids which contain pseudozoogloecae, *i. e.*, small adherent masses of bacteria of various shapes and floating in the culture fluid.
- FLUORESCENT**, having one color by transmitted light and another by reflected light.
- GRAM'S STAIN**, a method of differential bleaching after gentian violet, methyl violet, etc. The + mark is to be given only when the bacteria are deep blue or remain blue after counterstaining with Bismark brown.
- GRUMOSE**, clotted.
- INFUNDIBULIFORM**, form of a funnel or inverted cone.
- IRIDESCENT**, like mother-of-pearl. The effect of very thin films.
- LACERATE**, having the margin cut into irregular segments as if torn.
- LOBATE**, border deeply undulate, producing lobes (see *undulate*).
- LONG**, many weeks, or months.
- MAXIMUM TEMPERATURE**, temperature above which growth does not take place.
- MEDIUM**, (time) several weeks.
- MEMBRANOUS**, growth thin, coherent, like a membrane.
- MINIMUM TEMPERATURE**, temperature below which growth does not take place.
- MYCELIOD**, colonies having the radiately filamentous appearance of mold colonies.
- NAPIFORM**, liquefaction with the form of a turnip.
- NITROGEN REQUIREMENTS**, the necessary nitrogenous food. This is determined by adding to *nitrogen-free* media the nitrogen compound to be tested.
- OPALESCENT**, resembling the color of an opal.
- OPTIMUM TEMPERATURE**, temperature at which growth is most rapid.
- PELLICLE**, in fluid bacterial growth either forming a continuous or an interrupted sheet over the fluid.
- PEPTONIZED**, said of curds dissolved by trypsin.
- PERSISTENT**, many weeks, or months.
- PLUMOSE**, a fleecy or feathery growth.
- PSEUDOZOOGLOEAE**, clumps of bacteria, not dissolving readily in water, arising from imperfect separation, or more or less fusion of the components, but not having the degree of compactness and gelatinization seen in zoogloecae.
- PULVINATE**, in the form of a cushion, decidedly convex.
- PUNCTIFORM**, very minute colonies, at the limit of natural vision.

- RAISED**, growth thick, with abrupt or terraced edges.
- RHIZOID**, growth of an irregular branched or root-like character, as in *B. mycoides*.
- RING**, same as **RIM**, growth at the upper margin of a liquid culture, adhering more or less closely to the glass.
- REPAND**, wrinkled.
- RAPID**, developing in 24 to 48 hours.
- SACCATE**, liquefaction the shape of an elongated sack, tubular, cylindrical.
- SCUM**, floating islands of bacteria, an interrupted pellicle or bacterial membrane.
- SLOW**, requiring 5 or 6 days or more for development.
- SHORT**, applied to time, a few days, a week.
- SPORANGIA**, cells containing endospores.
- SPREADING**, growth extending much beyond the line of inoculation, *i. e.*, several millimeters or more.
- STRATIFORM**, liquefying to the walls of the tube at the top and then proceeding downwards horizontally.
- THERMAL DEATH-POINT**, the degree of heat required to kill young fluid cultures of an organism exposed for 10 minutes (in thin-walled test tubes of a diameter not exceeding 20 mm.) in the thermal water-bath. The water must be kept agitated so that the temperature shall be uniform during the exposure.
- TRANSIENT**, a few days.
- TRUNCATE**, flat-ended, instead of tapering, rounded, or concave.
- TURBID**, cloudy with flocculent particles; cloudy plus flocculence.
- UMBONATE**, having a button-like, raised center.
- UNDULATE**, border wavy, with shallow sinuses.
- VERRUCOSE**, growth wart-like, with wart-like prominences.
- VERMIFORM-CONTOURED**, growth like a mass of worms, or intestinal coils.
- VILLOUS**, growth beset with hair-like extensions.
- VISCID**, growth follows the needle when touched and withdrawn, sediment on shaking rises as a coherent swirl.
- ZOOGLOEAE**, firm, gelatinous masses of bacteria, one of the most typical examples of which is the *Streptococcus mesenterioides* of sugar vats (*Leuconostoc mesenterioides*), the bacterial chains being surrounded by an enormously thickened firm covering, inside of which there may be one or many groups of the bacteria.

ADJUSTMENT OF REACTION OF MEDIA BY TITRATION WITH
PHENOLPHTHALEIN.

Required Apparatus and Solutions.—Two burettes (Fig. 69), (one at least with a rubber tube outlet for the alkali; the other may have a glass cock). A six-inch porcelain evaporating dish, with tripod, wire gauze and stirring rod. A Bunsen burner, cylinder graduate, and 5 c.c. pipette. Normal NaOH solution, normal HCl

solution and twentieth normal solutions of each, in well stoppered bottles, those containing the alkali stoppered with rubber, and protected with soda-lime (or KOH) U-tubes. Phenolphthalein solution ($\frac{1}{2}\%$ phenolphthalein (powder) in 50% alcohol, *i. e.*, 1 gram phenolphthalein, alcohol 100, water 100), and a 1 c.c. pipette.

Fig. 69.

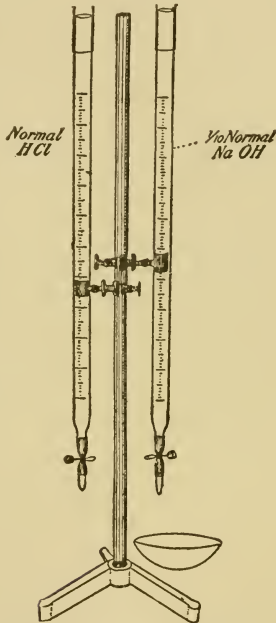

Two burettes arranged for titrating culture media.

Process.—Set the evaporating dish on the gauze, the gauze on the tripod, and measure into the dish 5 c.c.s of the media to be titrated. Add 45 c.c.s of distilled water. Boil freely one minute to expel CO_2 ; lower the flame until the liquid merely simmers; add 1 c.c. phenolphthalein solution; if no pink color develops, the media is

acid; a pink color shows it to be alkaline. If acid (as is usual), run in from the burette, drop by drop, stirring the mixture constantly, $N/_{20}$ NaOH until a faint, *permanent*, pink develops. The amount of $N/_{20}$ NaOH used to produce this color if read in c.c.s and fractions, gives directly the percentage of normal alkali theoretically needed to neutralize the medium; the same figure indicates the percentage acidity (in normal acid) of the medium as it is at the moment. The difference between the existing percentage acidity of the medium and the percentage acidity desired, read in c.c.s and fractions, indicates the amount of normal alkali or acid per 100 c.c.s of media which should (theoretically) be added, to attain the desired reaction.

Examples of Titration of Media.—1. If the filtrate (Step 3 schedule given above for making the principal artificial media) be titrated it will prove to be about 2.5% acid. The steps are:

(a) Remove 5 c.c.s to the evaporating dish; add 45 c.c.s neutral water. (The water is added merely to give enough bulk to boil, without too much evaporation or burning of the media, as might occur if 5 c.c.s of media, undiluted, were used.) The absolute quantity of water added is of no moment, but it is important that the same quantity be used in each titration, since the color developed when the phenolphthalein turns pink will vary in depth if the amounts of water added vary because of the variations in dilution thus introduced.)

(b) Boil 1 minute; the albumens coagulate and the reddish color of the meat infusion diluted by the added water largely disappears.

(c) Add 1 c.c. phenolphthalein solution.

(d) To the still simmering mixture add $N/_{20}$ NaOH as described above.

(e) If 2.5 c.c.s of $N/_{20}$ NaOH are necessary to neutralize the 5 c.c.s of meat infusion, 2.5 c.c.s of normal NaOH (twenty times

as strong as $N/20$ NaOH) will be required to neutralize 100 c.c.s of the infusion (twenty times as much as the five c.c.s actually tested). Since 2.5 c.c.s normal acid are (theoretically) necessary to neutralize 100 c.c.s of the infusion (in the case under consideration), the reaction of the infusion would be stated as equivalent to 2.5 c.c.s of normal acid per 100; or, briefly, "the infusion is 2.5% acid."

(f) The addition of the peptone (Step 3) scarcely alters the acidity as a rule: nor do the constituents mentioned under 5(a) and 5(b); but the addition of gelatin 5(c) and the action of *B. coli* 5(d) add considerably to the original acidity, as a rule. Hence the necessity for Step 6, which is thus performed: (1) Determine the existing acidity; suppose it to prove 2.8% acid. (2) Adjust to 1.5% acid thus: $2.8 - 1.5 = 1.3$; hence add to the medium 1.3 c.c.s normal alkali per 100 c.c.s. Theoretically, titration of the medium should now show 1.5% acid. In practice the acidity will prove to be higher, say 1.8%. As the desired reaction is 1.5 this means that $(1.8 - 1.5) .3$ c.c.s normal alkali per 100 c.c.s medium must still be added. Usually titration after this addition will yield the desired 1.5% acidity. If the acidity be still too high (say 1.6 then $1.6 - 1.5 = .1$) .1 c.c.s normal alkali per 100 c.c.s media must be added, and titration now will show that the desired point has at last been reached. Should any accident such as the addition of too much normal alkali occur, by which the medium is adjusted to a point *below* the point sought (*i. e.*, 1% acid, when 1.5% is desired) the difference between the existing acidity and the acidity sought will indicate the (theoretical) amount of normal acid to be added per 100 c.c.s of media, to restore it to the desired acidity (*i. e.*, .5 c.c.s normal acid in the case quoted). But media in the preparation of which any such departure from the regular course occurs should not be used for official or research work *on counts*.

Note: Normal NaOH is prepared in such a manner as to secure

a pure aqueous solution of NaOH containing exactly 40 grams per litre. Beginners often attempt to make the solution by weighing 40 grams of sodium hydrate sticks, dissolving in 700—800 c.c. water and making up to 1 litre, or even by adding 40 grams directly to 1 litre of water. Unfortunately, sodium hydrate is so hygroscopic that in the very process of weighing it will absorb water from the atmosphere sufficient to change its weight, so that it is impossible thus to prepare an accurate solution. A sufficiently accurate normal NaOH solution may be prepared (if pure oxalic acid is available) by dissolving 62.5 grams of oxalic acid in 700—800 c.c. water, making up exactly to 1 litre. This constitutes a normal acid solution. Dissolve about 50 to 60 grams NaOH, weighed quickly and roughly in 700 to 800 c.c. of recently boiled water (thus securing a solution CO_2 -free, and somewhat stronger than normal). Titrate the inexact NaOH solution against the exact oxalic acid solution, using the phenolphthalein solution as an indicator; it will be found that 5 c.c.s (say) of the NaOH require for neutralization (say) 7 c.c.s of the oxalic acid solution; hence 5 c.c.s of NaOH solution should be diluted to 7 c.c.s with water, in order that it should exactly equal in strength the oxalic acid solution. Hence 800 c.c.s (say) of the NaOH solution should be diluted to ($7/5$ of 800) 1,120 c.c.s in order to equal in strength, c.c. for c.c., the oxalic acid solution. Dilute with great care to a point somewhat short of the calculated figure (say, to 1,050 c.c.s,) and again titrate. If the NaOH solution still proves too strong (say that 5 c.c. of the NaOH solution now require 5.5 c.c.s of oxalic acid solution for neutralization), dilute again in the proportions thus indicated, $5.5/5$ of 1,045 (allowing for the 5 c.c.s withdrawn for titration), *i. e.*, dilute the remaining 1,045 c.c.s of NaOH solution with water to 1,149.5 c.c.s and check again. N_{20} solutions are prepared by accurately diluting 1 part of a normal solution to make 20 parts in all—*i. e.*, dilute 50 c.c.s normal NaOH with distilled water to make one litre.

It is best when possible to have the normal NaOH prepared

by an expert chemist, who will probably prefer to prepare a normal alkaline solution from chemically pure sodium carbonate, fused; a normal acid solution of HCl by titration against this; and a normal NaOH solution by titration against the normal HCl.

To prepare a normal HCl acid solution by titration against the normal NaOH solution, take about 100 c.c. of chemically pure hydrochloric acid (sp. gr. 1.20) and dilute to 1 litre, making thus a solution slightly stronger than normal. Titrate this against the normal NaOH solution. It will prove to be stronger and the figures obtained will, as described above, for the making of normal NaOH from oxalic acid, indicate how much it should be diluted to make it equal, c.c. for c.c., the strength of the normal NaOH solution.

CHAPTER XIV

LABORATORY WORK IN DAIRY BACTERIOLOGY*

BY PROFESSOR H. W. CONN

THE directions for these experiments are given in sufficient detail, so that anyone with a fair knowledge of laboratory methods can follow them without other instruction. The private student of dairying may, therefore, carry out this laboratory course by himself, although it will take more time in this case than if adequate personal instruction were obtained.

Special emphasis should be placed upon the necessity of carefully *labeling* every culture made and recording in a note book each experiment, its purpose and results.

PRACTICAL WORK.†

I. *Washing Glassware.*—All glassware used in bacteriological work must be thoroughly washed. No special directions need

* The following pages, containing practical experiments to be performed in the laboratory, are taken by the kind permission of Prof. Conn from his *Practical Dairy Bacteriology*, published by Orange Judd Co., New York.

† The following laboratory manuals may be found useful as books of reference:

Moore. *Laboratory Directions for Beginners in Bacteriology.* Ginn & Co., 1900.

Frost. *A Laboratory Guide in Elementary Bacteriology.* The Macmillan Co., 1903.

Gorham. *A Laboratory Course in Bacteriology.* W. B. Saunders, 1901.

Van Slyke. *Methods of Testing Milk and Its Products.* Orange Judd Pub. Co., 1906. *Bacteriology Of Milk*, Swithinbank and Newman, E. P. Dutton & Co., N. Y., is the most elaborate and complete work on the subject, containing detailed description and beautiful plates of bacteria in milk.—K. W.

be given save that hot water and soap are necessary. New glassware should be treated first with 1% HCl. Used glassware that contains the remains of gelatin or other media must first be boiled in water, preferably containing a little sal soda or powdered soap. After boiling, wash well in hot water and then rinse thoroughly in clear cold water; drain and allow to dry.

2. *Comparison of Yeast and Bacteria.*—Rub up in a watch glass a bit of a cake of yeast with a little water. Place a drop of the liquid on a slide and examine directly with the microscope, using a $\frac{1}{6}$ -inch objective. Dry a little of the material on a slide and stain exactly as in staining bacteria (No. 3). Study with the immersion lens, comparing the yeast cells as to *size* and *shape* with bacteria already studied. Hunt for cells showing *budding*. If these are not found they may be obtained in quantity by planting a little yeast in a weak solution of molasses in water and allowing to grow for a few hours in a warm place. Make a sketch of the yeast cells with buds, showing their relative size to that of bacteria.

3. *Direct Microscopic Study of Milk.*—For this a centrifuge is needed, having tubes with straight sides, and closed at the bottom with a rubber cork. Place 2 c.c. of the samples of milk to be tested, after thorough shaking, in the tubes. It is necessary to fill enough tubes with milk from different samples, to balance the centrifugal machine on both sides. Rotate in the machine at a rate of 2,000 to 3,000 per minute, for 5 minutes. Remove the tubes from the machine and they will be found to have a layer of cream at one end, and a small slimy deposit at the other end, next the cork. Holding the tube with the cream end down, remove the cream with a platinum loop, and pour out the milk gently. A slimy sediment will be left attached to the cork. Carefully remove the cork with its adhering sediment, and smear over the surface of a glass slide, with a drop of sterile water, to cover an area of exactly four square centimeters. Special slides marked with wax pencils into such areas are needed. This distribution of the sediment must.

be carefully done in order that it should be uniform. After the thorough distribution, dry in gentle heat, or without heating, and stain by flooding the surface with dilute solution of methylene blue for a short time, and then wash the stain away. After again drying, the material may be mounted under cover-glass, or it may be examined immediately with an immersion lens without a cover-glass. There will be found on the slide a considerable number of stained bacteria, usually showing a variety of forms, and also a varying number of large cells, most of which have deeply stained nuclei, but unstained bodies. These latter are *leucocytes*, and represent cells of the character of the white blood cells from the cow, which have found their way into the milk. In some cases, leucocytes represent *pus* cells and are indicative of inflammatory changes in the animal's udder. Where the numbers are small, however, they give no such indication, for the normal milk of healthy udders will usually show considerable numbers of these leucocytes. To interpret the meaning of what is found under the microscope in these preparations, see section 4.

4. *Doane's Method of Determining Leucocytes*.—Place 10 c.c. of milk in the tubes of a centrifugal and rotate at about 2,000 per minute for four minutes. Carefully remove the cream from the surface with a bit of cotton on the end of a rod, being careful not to leave any of the cream in the tube. By means of a small siphon remove the milk, keeping the tip of the tube just below the surface so as to avoid disturbing the sediment. Siphon away the milk to within about one-eighth of an inch of the sediment. Add two drops of a saturated alcoholic solution of *methylene blue* to the tube, and, after thoroughly mixing, place the tube in boiling water for two minutes to aid the staining. Add enough water to bring the total bulk either to one or two c.c., according to the amount of sediment. This will give a blue mass of stained sediments. To count their number an ordinary blood counter is used. This will have a counting chamber marked off into squares and holding ex-

actly one-tenth of a cubic millimeter. Fill this counter with the stained sediment, cover with a cover-glass, allow to stand for about one minute for the leucocytes to settle, and then, placing under a microscope, count the number of leucocytes found in a single ruled square and calculate the numbers in the whole chamber. Remembering then that the chamber contains one-tenth of a cubic millimeter of the stained sediment, it is easy to calculate the number of leucocytes in the original milk. This should be calculated upon the basis of a certain number per c.c., and good milk should not have more than 500,000 per c.c.*

5. *Separation of the Common Species of Bacteria from Milk.* Allow some milk to stand at about 70°. As soon as it begins to sour, but before it curdles, dilute 1 c.c. 500,000 times and make litmus gelatin plates. Allow to grow four days at 70° unless liquefiers make it impossible.

- a. Determine the total number of bacteria in 1 c.c. of milk.
- b. Determine the number of acid bacteria per c.c.
- c. Determine the number of liquefiers per c.c.
- d. Determine the *percentages* in each case.

e. Isolate a colony of *Bact. lactis acidi*. This may be recognized as follows: It is an intensely acid colony, rather opaque, always below and never on the surface. It is small, only just visible to the naked eye and when examined under a low power microscope it frequently, though not always, shows a slight roughness, looking like minute spines around its edge. With a platinum needle lift out one of these colonies and inoculate into a gelatin tube by stabbing the needle directly into the gelatin. After growth, set aside for future use.†

* In healthy cows the leucocytes in milk may range as high as 1,500,000 (Russell) to 4,500,000 (Savage). In healthy cows the leucocytes average over 100,000 (Savage), or 2000,000 (Doane). 83% of cows with mastitis (Russell) yield milk containing over 500,000 leucocytes per c.c. Prolonged retention of milk in the udder gives rise to increased leucocyte content.—WINSLOW.

† For special characteristics, see Conn's "Practical Dairy Bacteriology."

f. Look over the plates made in this experiment and see if any large (usually about the size of a pinhead) colonies appear on the surface, white in color and intensely acid. If so, isolate one, preferably one that shows a gas bubble beneath or beside it. Inoculate upon an agar slant, labeling it *Bact. aerogenes*(?). Whether it is really that species will be determined later. If no gas bubbles appear, isolate several of the large, acid, surface colonies and some of them will probably prove to be the species desired.

In the same way isolate and inoculate on agar slants one rapid and one slow liquefier, and several of the neutral type of colonies.

6. *Milk Agar*.—Add 1.5% agar to some skim milk. After half an hour boil (better to heat in an autoclave) until the milk curdles into a custard. Replace water of evaporation; adjust re-

Fig. 70.

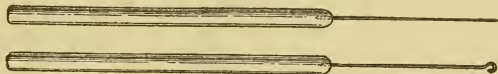

Platinum Needles.

action to 1.5% acid; filter through absorbent cotton; place in tubes and sterilize in the usual way. After the third sterilization slant the tubes and allow to harden. This milk agar is not so transparent as ordinary agar, but the lactic bacteria grow upon it more readily.

7. *Oidium Lactis*.—Procure a little soft cheese from market, preferably of the Camembert or Brie type.* Pour out into a petri dish a tube of plain gelatin, and into another a tube of litmus gelatin. Allow to harden. With a platinum needle scrape off a little of the growth on the rind of the cheese and touch it upon the surface of the gelatin at several spots. It is well to try several parts of the cheese rind in this way. Cover, and after two days' growth it will usually be possible to find spreading colonies of

* If such soft cheese is not to be found conveniently, *oidium lactis* can usually be found in samples of old tub butter.

Oidium on the plates. They are thin, and spread rapidly over the surface; they may be recognized under the microscope because at first they are seen to be composed of threads like a mold, which soon break up into short sections. The colonies usually become about $\frac{1}{4}$ inch in diameter.

8. *Cheese Mold*.—On the same plates, after 2 or 3 days, will appear a white mold. This grows more slowly than the *Oidium*,

Fig. 71

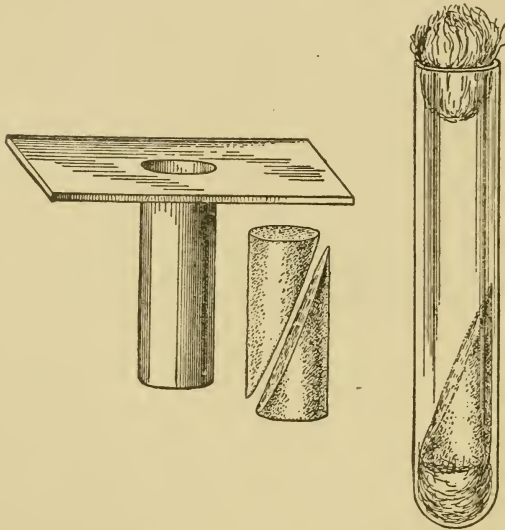

Cutter for Making Potato Plugs, Method of Cutting them and Placing Them in Tubes.

and its threads do not break up into spores. Spores form on the surface upon special branches.

Both the *Oidium* and *mold* may be isolated for future study if time permits.

9. *Testing Characters of Bacteria*.—Inoculate the several bacteria previously isolated and purified, into various media. In doing this it is best to make first a fresh agar slant from each

bacterium to be tested, so that the inoculation may be made from a culture not over 24 hours old. Inoculate with a small amount of the growth from the agar surface, the following:

a. An agar slant. *b.* A gelatin stab. *c.* A tube of plain bouillon. *d.* A dextrose fermentation tube. *e.* A lactose fermentation tube. *f.* Two milk tubes, one to be kept at 70° and the other at 98° . *g.* Two potato tubes, one at 70° and one at 98° . Allow the cultures to grow several days, examining each day. For each species of bacterium make a careful record, noting especially the following points:

Agar slant. Note the type of surface growth.

Morphology. Stain and study with the microscope, noting shape—formation of chains—spores—determine motility.

Gelatin stab. Note liquefaction—needle growth—surface growth—color. Compare the growth with the different types shown

Fig. 72.

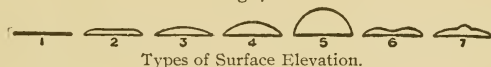

- Types of Surface Elevation.
 1. Flat. 2. Raised. 3. Convex. 4. Pulvinate. 5. Capitata. 6. Umbilicite.
 7. Umbonate.

in figure 73, and determine with which each agrees. Note the amount of elevation of the surface growth.

Bouillon. Note turbidity—scum—sediment.

Fermentation tubes. See below (No. 10).

Milk tubes. Note at 70° and 98° the development of acid as shown to litmus paper—curdling—separation of whey—appearance of *gas bubbles*—subsequent *softening of the curd*, called digestion.

Potato tubes. At 70° and 98° . Note *color* of growth—*abundance* of growth—*texture* of growth—*discoloration* of potato.

By such characters as above determined, different kinds of bacteria are distinguished and described. For a complete description, more characters than those mentioned are necessary.* For

* For more detailed description of special bacteria, see Conn's "Practical Dairy Bacteriology."

characters of the cultures which have been named, *Bact. lactis acidii* and *Bact. aerogenes*, see No. 5.

10. *Fermentation Tubes*.—Inoculate a series of fermentation tubes (dextrose, lactose and saccharose) with different bacteria. Among those chosen should be one culture of *Bact. lactis acidii*, and one of *Bact. aerogenes*. In two days, note whether gas has been produced in the closed arms, and, by means of litmus paper, whether the bouillon has become acid. If gas shows in the fermentation tubes, determine the gas ratio as follows:

Without disturbing the gas, fill up the bulb to the top with a 2% NaOH. (By a mark, note the level of the gas in the glass arm.) Place the thumb over the opening in such a way that there will be no air bubble between the thumb and the surface of the liquid. Now invert the tube, allowing the gas to flow out into the bulb, and, by turning back and forth, mix the gas with the NaOH solution in the bulb, keeping the thumb very tightly closed over the opening. After thoroughly mixing, turn the tube once more so that all of the gas will be in the closed arm. Remove the thumb; it will usually be found that the level of the gas in the closed arm rises. If so, it will be due to the fact that CO_2 has been dissolved by the NaOH solution. By determining the amount of the gas before and after the test, the proportion of CO_2 to the gases not thus dissolved may be obtained. This is called the *gas ratio*. Some gas-producing species of bacteria produce large quantities of carbon dioxide, and small quantities of other gases, while other species produce no carbon dioxide.

From one or two of the test tubes inoculated above, that show an acidity, determine the amount of acid produced. For this purpose remove from the tube either 5 or 10 c.c. of the liquid, dilute it with 10 times its bulk of water, heat and titrate.

11. *To Determine Motility*. Inoculate a little of the bacteria growth of No. 21 into a test tube of bouillon. Allow it to grow for about 24 hours. By this time the liquid will become some-

what cloudy. Transfer a loopful of this material to a glass slide and place upon it a cover-glass. Place the whole under a microscope, preferably using a $\frac{1}{6}$ -inch objective, and narrow the diaphragm below the stage until most of the light has been cut off. Now focus very carefully upon the bacteria under the cover-glass, and, if they are motile, it will be seen that they are moving around through the microscope field with more or less rapidity. If they are stationary, it may be assumed that they have no flagella. This test requires great care, for with some slowly moving forms it is not always easy to detect the motion with certainty; but it can easily be done with a little study.

Fig. 73.

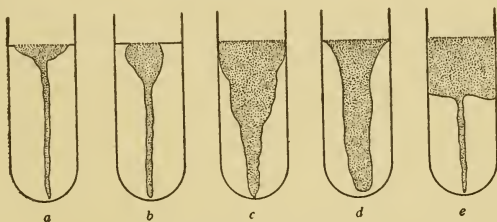

Types of Gelatin Liquefaction

a. Crateriform. *b.* Napiform. *c.* Infundibuliform. *d.* Saccate. *e.* Stratiform.

12. *Germicidal Action of Milk.* Procure some milk fresh from the cow; dilute 1 c.c. of this milk 100 times and make 6 agar (or gelatin) plates. Cool the rest of the milk at once to 70° . At the end of 2 hours make 6 more plates in exactly the same way as above. In 2 hours more make 6 more plates. After proper time for growth, count the colonies and determine whether there has been a decrease in numbers of bacteria in the first few hours after milking.

13. *Aseptic Milk.* Sterilize a liter flask plugged with cotton. Wash the hands thoroughly in hot water and soap, and put on a clean milking suit. Remove a clean cow from the barn into the open air, brush the dirt from the flanks and udder with

a clean brush and then with a damp cloth. Wash the udder and especially the teats with a 10% borax solution. After drawing about a dozen jets on to the ground, remove the plug from the flask and, placing its mouth very close to the teat, milk it about half full, and replace the cotton plug. Carry at once to the laboratory and make a litmus gelatin plate immediately, diluting 10 times. After 2 or 3 days' growth, count the colonies. Are there any acid colonies of the *Bact. lactis acidi* present? If time permits, isolate the colonies; purify and determine the general class of bacteria.

Allow the rest of the milk to stand at about 70° to see if it will sour normally.

14. *Effect of Temperature on Species of Bacteria in Milk.*—Procure some fresh milk and make several litmus gelatin plates, diluting 100 times. Divide the milk in three lots, placing one at about 50°, one at 70°, and one at 98°. At the end of 24 hours make plates from each, diluting that kept at 50° 2,000 times, that at 70° 10,000 and 100,000 times, and that kept at 98° 500,000 times. After another 24 hours, make some plates from the sample at 70°, diluted 10,000 times. Allow all plates to grow at room temperature until the colonies are well developed. Determine the total number of bacteria in each sample, and the number and percentage of each kind of bacteria that can be clearly distinguished by its colony. Compare the numbers and percentages of the different species at the different temperatures.

15. *Bacteria of the Air.*—Place one dozen tubes of sterilized milk—with cotton plugs removed—in various places around the barn, dairy, house and laboratory. Leave undisturbed for 6 hours. Then replace the plugs, carry all to laboratory, and place at about 70°. Watch for several days and notice whether all appear to undergo the same kind of fermentation. Do any of them sour normally? Do any remain unchanged?

16. *Types of Bacteria from the Air.*—After the tubes in No. 15 show signs of fermentation make a gelatin plate from

each, using a loopful of the milk in a water blank and inoculating gelatin tubes with a small loopful of the water blank dilution. After proper growth examine the colonies in the different plates and compare with each other. What does the experiment teach? If time permits, the colonies may be isolated, purified and further studied.

17. *Dust Plates.*—Pour 12 tubes of melted gelatin into petri dishes; cover and allow to harden.

a. During the milking of a cow hold one of the above gelatin plates under the udder of the cow, close to the milk pail; remove the cover so as to allow any dust particles to fall on the gelatin, for half a minute. Replace the cover and carry to the laboratory.

b. Place 3 of the flasks at different places in a cow barn several hours after feeding. Remove the covers for 3 minutes. Replace covers and carry to laboratory.

c. Repeat *b* ten minutes after feeding the cows with hay.

d. Repeat *c* after feeding with other foods.

e. Expose one plate the same length of time out of doors.

After the above plates have developed count the colonies on all the plates and compare.

18. *Bacteria in Hay.*—Soak a little hay in warm (not hot) water for an hour. Shake well and inoculate three litmus gelatin tubes, the first with one, the second with two and the third with three loops full of the hay infusion. Pour into petri dishes, incubate and study as usual. Compare the numbers of liquefiers and non-liquefiers. Are there any acid-forming colonies?

19. *Bacteria in Grain.*—Repeat the above experiment, using some grain feed instead of hay.

20. *Value of Cleaning Milk Bottles.*—Procure 4 glass bottles in which milk has been standing for a day; ordinary unwashed milk bottles are best.

a. Wash one with cold water.

b. Wash one with hot water and soap.

c. Wash the third and sterilize in steam.

d. Leave fourth unwashed.

Fill all four with fresh milk. Place all side by side at a room temperature and notice the time of souring in each case.

21. *Bacteria in the Milk Pail*.—Place 100 c.c. of sterile water in a milk pail that has received a simple washing. With a little absorbent cotton rub this water around thoroughly; allow to stand a few moments, and, after another washing around the pail, remove 1 c.c. of this water and plate in agar. Count the colonies.

a. Repeat, using (1) a dirty pail; (2) a pail simply steamed for a few seconds in a steam jet, and (3) a thoroughly sterilized pail.

22. *Bacteria in Manure*. With a sterilized platinum loop transfer a small bit of either fresh or dried manure from a cow to sterile water flask. Mix thoroughly. Transfer two loopfuls of the mixture to a tube of melted agar. Pour into petri dishes and after growth count the number of colonies. To determine the *actual number* in manure it is necessary to weigh the original bit of manure and make subsequent calculations.

23. *Isolation of B. Coli*.—Repeat No. 22, using litmus agar. If any strong acid surface colonies appear, choose one that shows a gas bubble if possible; isolate, inoculate on an agar slant, and purify as usual. From the purified culture inoculate a glucose fermentation tube. If gas appears, examine the culture and determine whether the bacterium is a short motile rod. If so, the species is probably *B. coli*; if it is not motile, it is probably *B. aerogenes*. Compare with page 296, f.

24. *Bacteria on Hair*.—Melt a tube of agar and one of gelatin, and pour into petri dishes. After they have hardened place upon the surface of each one or two hairs from the flank of a cow. Two or three days later examine, and note the numerous bacterial colonies growing along the course of the hairs.

25. *Fore Milk*.—Draw the first 3 jets of milk from one:

teat of a cow into a sterile test tube. Now milk the cow about one-half dry and draw 6 more jets in a second sterile tube. Remove to laboratory and plate at once in plain gelatin, diluting 10 times. Compare the numbers and kinds of colonies in the two sets of plates.

26. *Bacteria on the Hands.*—Wash the hands thoroughly in 200 c.c. of sterile water. Place 1 c.c. of this water in a tube of melted agar. Count the colonies and calculate the number of bacteria removed from the hands by washing.

27. *Estimation of Dirt in Milk.**—Procure some milk from a clean and carefully kept dairy and also some from a dairy where the milking is done in a careless, slovenly fashion. Determine the amount of dirt in the milk in each case, as follows:

a. *First method.* Place a quart or a liter of each sample of milk in a tall glass cylinder, and allow it to stand for several hours. A deposit of dirt will collect at the bottom, which may easily be seen by looking through the glass. With a siphon carefully remove the milk to within $\frac{1}{4}$ inch of the bottom, but do not disturb the sediment. Fill up with clean water and allow to settle again. Once more, after settling, siphon off the liquid, and fill the glass with water. Repeat this operation several times, until the water becomes fairly clear. Then, after allowing the material to settle again, siphon off a considerable portion of the liquid, and after thoroughly mixing the sediment with the remainder of the water in the cylinder, pour it through carefully weighed filter paper; wash the filtrate by means of water through the filter paper. Remove the filter paper and dry, until it comes to a constant weight. Weigh. The difference in weight between this and the original weight of the filter paper will give the weighed amount of dirt collected.

b. *Second method.* Place a definite quantity of milk, usually 10 c.c., in one of the glass tubes of a centrifugal machine. Set the

* This experiment is impossible without a chemist's balance and apparatus for drying, such as used in quantitative chemistry and analysis.

machine in motion and rotate rapidly for ten minutes. By this time the sediment will mostly be thrown to the smaller end of the tube. The cream and milk are then to be carefully removed from the sediment with a pipette, and the tube filled up again with clean water and centrifugalized again. This is to be repeated until the water becomes clear, after which the sediment in the bottom of the tubes is to be carefully washed out with clean water upon a filter, and the rest of the procedure is as above.

c. Third method. Procure some bolting cloth of the *finest* mesh. The meshes should be fine enough to retain all the visible particles, but to allow fat particles to pass through. Place in a ribbed funnel, moisten with water, and pour through it one quart (or liter) of milk. Wash the material left on the cloth with water and then with a mixture of ether and alcohol, equal parts. Wash the dirt on to a carefully weighed filter paper. Dry thoroughly and weigh as above.

28. *The Covered Milk Pail.*—Milk two cows, one into an ordinary milk pail with a flaring, open mouth and the other into a covered milk pail. Determine the amount of dirt in the milk in each case. Immediately after the milking, in each case, make a quantitative count of the number of bacteria, comparing the results together, and determine the value of a covered milk pail. The next day repeat the experiment, reversing the two cows.

29. *Advantage of Immediate Cooling.*—Immediately after milking, cool, by aerating, part of the milk, and place in sterilized jar. Fill another similar jar with milk not cooled. Fill a third jar with milk cooled by immersing at once in iced water. Place all three jars side by side in an ordinary room and compare the time of souring and curdling in the three specimens.

Cool night's milk immediately, as cool as possible. The next morning fill two jars, one with the night's milk that has been cooled and the other with the milk warm from the cow. Place both at a

temperature of an ordinary room and compare the time of souring and curdling in the two cases.

30. *The Effect of Careful Milking.*—Compare the effect of milking, for six successive days, with and without precautions. The first three days use open milk pails and make no special attempt at cleanliness. The second three days use closed milk pails, groom the cows, wash the udders and perform the milking out-of-doors instead of in the closed barn. In each case make a quantitative analysis of the number of bacteria in the milk and compare the results.

31. *Sterilization by Boiling.*—Make a set of bacterial plates from a sample of milk gelatin. Then boil the milk for five minutes in a flask closed with cotton and make another set of plates, diluting by 10. Allow the boiled milk to stand for 24 hours and make another set of bacterial plates, diluting by 100. Allow the rest of the boiled milk to stand in the laboratory until it shows signs of fermentation. Determine whether it has soured, and describe any other notable change. After the plates have had an opportunity to grow, count the number of bacteria.

32. *Pasteurizing Milk.*—Obtain some milk that is from 12 to 20 hours old. Make a set of plates on agar, diluting by 1,000. Divide the milk into two lots. Heat one lot to a temperature of 140° for one-half hour, stirring frequently. Heat the other lot to 160° for 10 minutes. Allow both to cool and make agar plates from each, diluting by 100. After plates have grown, calculate the number of bacteria before and after pasteurizing at the different temperatures.

a. Repeat the last experiment, making plates, however, in litmus gelatin and calculating the number and percentage of acid colonies in the milk before and after pasteurizing.

33. *Quantitative Analysis of Miscellaneous Milk Samples.*—Obtain milk samples from several milkmen, learning, so far as possible, the age of each sample of milk. These should be collected in sterile bottles and kept on ice until they can be experimented

with in the laboratory. Dilute each sample of milk 1,000 times and make agar plates from the final dilution; incubate at 98° . After 24 hours count the number of bacteria in each plate and compare the samples of milk.

34. *Qualitative Analysis of Miscellaneous Milk Samples*—With the specimens above collected it will be useful to attempt a qualitative analysis, though this will be more difficult. The dilution of the milk must be varied according to its age and temper-

Fig. 74.

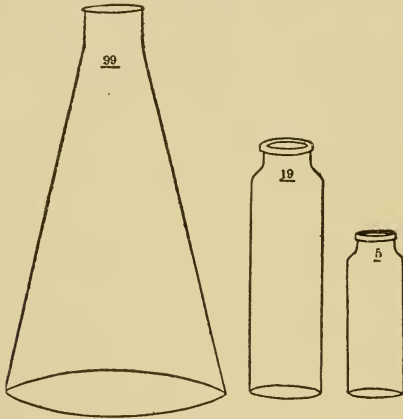

Flasks and vials for quantitative bacteriological analysis.

ature. If it is fairly fresh—only a few hours old—a dilution of a thousand times is satisfactory. If it is 12 hours old, a dilution should be, at least, 10,000; and if 24 hours old, it should be as high as 100,000, or higher. The amount of dilution necessary may be determined by a direct microscopic study. Make and stain a slide from each sample of milk, as directed in No. 3. Count the number of bacteria per field. If the average number per field is less than 10, dilute the milk 100 times. If it is as high as 100, dilute 1,000 times; and if still higher, dilute in the same proportion.

After diluting the milk make six litmus gelatin plates from each sample. It is best to have three of these plates diluted twice as highly as the other three. After cooling, place at a temperature of 70°. After two days, examine and determine whether there are any rapidly liquefying colonies that are likely to destroy the plates; if so, make a study of the plates at once. If possible, however, keep the plates for four days before studying them.

Study of plates.—After the plates have grown (2 to 4 days), study as follows:

a. Determine *total number* of bacteria per c.c. of milk. Compare with the total number found on the agar plates.

b. Determine the number of *liquefying colonies*.

c. Determine the number of *acid bacteria* per c.c. Are they of the *Bact. lactis acidi* type?

d. Calculate the *percentage of acid bacteria*—liquefiers and miscellaneous bacteria in the milk. Draw a conclusion as to which samples were probably badly contaminated.

35. *Bacteria in Fresh Cream.*—Dilute one c.c. of freshly separated cream with sterile water. If this is separated by a separator, the dilution should be about 1,000. If the cream has been separated by the gravity method, the dilution should be higher, since the cream is older, and should be as high as 100,000. After diluting, make a series of four plates in litmus gelatin, incubate at 70° and study as described in No. 56.

36. *Bacteria in Ripened Cream.*—Repeat experiment No. 35, using, however, some ripened cream that is just ready for churning. In this case the dilution must be much higher, and probably never less than 1,000,000. After incubating, determine the variety and numbers of bacteria present.

37. *Analysis of Butter Milk.*—Make an analysis of the bacteria in butter milk in litmus gelatin. The dilution in this case should not be less than 100,000.

38. *Analysis of Butter.*—Weigh out upon accurate chem-

ical scales 5 grams of freshly made butter. Place this in a sterile mortar, with 9.5 c.c. of sterile water. Rub the water and the butter together thoroughly, so as to distribute the bacteria as uniformly as possible through the water. This mixing should be continued for some time, for, at best, many of the bacteria will remain clinging to the fat. Dilute this mixture 10,000 times and make a series of agar or litmus gelatin plates. Incubate and count as usual.

After 24 hours make a second series of plates from the same sample of butter, and repeat again in two days and one week. Obtain, if possible, a sample of butter several months old, and make similar analysis. In all cases determine the numbers, and, if possible, the proportion of acid bacteria and the liquefiers.

39. *Home Starters.*—Obtain some clean milk from a thoroughly healthy cow; place in sterile vessels, and cover to keep out the dust. Set aside at about 65° until the milk is soured but not quite curdled. Examine carefully by taste, by smell and by general appearance, to determine whether the curd seems to be of a type favorable for butter-making. It should be smooth in appearance, and have a clean, sharp taste and pleasant odor. Use this, if convenient, as a starter for ripening cream.

40. *Making a Starter from a Commercial Culture.*—Sterilize a quart of milk by boiling half an hour, or half an hour in an autoclave at 10 pounds pressure. After cooling to about 80° , pour into it the contents of a package of commercial butter starter, stir thoroughly, cover and allow to stand at 65° to 70° for 24 hours. The milk should by this time be sour and nearly ready to curdle, and may be used at once as a starter. If a larger amount is needed, pasteurize several gallons of cream by heating to 155° for one half hour. Cool to 80° , and pour into it the quart of starter prepared from the commercial culture. Allow to stand at 65° , after which it is ready for use.

41. *Bacteriological Analysis of a Commercial Culture.*—Make a bacteriological analysis of some commercial culture to de-

termine whether it is pure or not. For this purpose put a small quantity of the culture from the package into a water blank, and, by thorough agitation, distribute evenly through the water. From this inoculate litmus gelatin tubes, some with one, some with two and some with three loopfuls of the diluted culture. Pour into petri dishes, incubate at 70° , and after three days examine to see whether any bacteria can be found in the plate except lactic germs.

42. *Effect Upon Butter of Pasteurizing Cream.*—Divide a lot of cream which is to be made into butter into two parts, pasteurize one at a temperature of 155° for 15 minutes, leaving the other without pasteurization. Add to each the same amount of starter. Ripen in the usual way, churn and make into butter, and compare the products, to see if any difference can be noted between the butter from pasteurized and non-pasteurized cream.

43. *The Effect of Light Upon Butter.*—Place two lots of butter, one in a bright light and one in the dark, and after several days compare them as to appearance, smell and taste.

44. *Ripening of Cream at Different Temperatures.*—Divide some cream into three lots. Place the usual amount of starter in the cream, and ripen one lot at 50° , one at 65° and one at 85° . After proper ripeness has been reached (determined by acid test), churn and compare the butter which is obtained, unsalted, to detect any difference in flavor and aroma.

45. *Analysis of Bacteria in Cheese.*—Determine the number of bacteria in cheese exactly as above described for butter (see experiment 38), making inoculation into litmus gelatin plates, and determine the varieties of bacteria present. Make a series of plates in this way from a freshly made cheese and another series from some cheese ripened and ready for market. Compare the numbers and kinds of bacteria.

46. *Effect of Different Species of Bacteria on Milk.*—Inoculate a series of sterile milk tubes with a large number of different kinds of bacteria. It is well for this purpose to use all of the species

isolated during these experiments, and as many other kinds of bacteria as may be available. Set all of the tubes aside at 70°, and at intervals of 24 hours examine each to determine the effect upon the milk of the different species of bacteria. The acidity should be tested by removing a loopful and placing on litmus paper, and special attention should be given to curdling, separation of whey, appearance of gas bubbles, the digestion of the curd and the appearance of odors as a result of the action of the different bacteria. The larger the variety of the different cultures used, the better.

A P P E N D I X

Dairy Cows

THE writer has not said anything about the best kind of cow for producing clean milk, because it is as impossible to affirm positively which is the best breed of dairy cows as it would be to state which is the best race of human beings. Each breed has its own valuable characteristics which are in accord or otherwise with the views of different cattle owners, depending on the experience, temperament or characteristics of the owner.

The dairy breeds of chief importance are four: The Jerseys, Guernseys, Holsteins and Ayrshires. The Brown Swiss and Short Horn are called dual purpose cows; that is, useful for milk and beef. For dairy purposes alone they are inferior to the first four breeds mentioned, however.

The milk of the Jerseys and Guernseys is rich in fat, but moderate in amount (the Guernsey milk of especially deep yellow color); the Holsteins are large milkers, but the percentage of fat in their milk is low; while the Ayrshires occupy an intermediate position—in respect to quantity and richness of their milk—as compared with the Jerseys and Holsteins. The milk of Jerseys and Guernseys is said to be not quite so digestible for infants, perhaps on account of its larger fat globules. This is apparently without true basis, however, since the fat globules in human milk are larger than those in milk of any breed of cows (see p. 45). If milk is fed undiluted to babies under nine months, Jersey and Guernsey milk is undoubtedly too rich. If this method of feeding is adopted, milk containing 3.5 per cent. fat or less must be used. The milk is said to vary more in composition, in case of the pure bred Jerseys (on account of their excitable temperaments), and these animals are possibly more prone to tuberculosis. Clean Jersey or Guernsey milk is, however, infinitely preferable to the ordinary dirty market milk of any other breed of cows, and the writer has found that clean milk from grade Jersey cows (containing 5 per cent. fat) will agree perfectly with infants, providing that it is diluted properly in accordance with its fat content, see p. 170. The average consumer

of milk places much more importance on the richness of milk than any other quality. He can easily see and appreciate this quality, and the cleanliness of the milk he can not judge of—except to notice that it keeps well. Moreover, the average consumer buys the milk largely for the cream, which is commonly used for the breakfast cereal and coffee. For this reason a rich milk should bring the largest price, providing that it is clean.

A Holstein or Ayrshire milk—or a clean milk obtained from cows of various breeds—may be sold for infants, and a 5 per cent. Jersey or Guernsey milk may be sold for general consumption at a little higher figure.

If the whole milk is drunk by adults its richness is considered its most valuable quality. In Boston a milk containing 6 per cent. of fat—which may be obtained from some Jerseys and Guernseys—is sold for 16 cents a quart, and is especially intended for invalids. It is not unusual to separate the milk from different breeds on the farm and charge different prices for their milk. Milk intended for babies may appropriately contain about 4 per cent. of fat, and must be of special cleanliness and freshness. Rapid delivery of it is therefore necessary, which may require a special express rate on train and special wagon in the city. The bottles should be thoroughly protected from dust by an outer cap of parchment, or tinfoil, over the ordinary paper cap. A milk for infants should constantly contain nearly the same quantity of fat, so as to give rise to a cream of uniform composition. This is essential for the physician to calculate the fat in the different layers of cream (see p. 170), and such milk may be supplied if it is obtained from one breed of cows. For all these reasons the price of milk for infant feeding must be considerable—generally 15 cents a quart retail. A five per cent. milk from Jerseys or Guernseys (not quite up to the certified standard for babies) may be sold for general household use for from 10 to 12 cents a quart.

To give the reader an idea of representative cows of the dairy breeds we have included an account of a Guernsey, which heads the list of officially tested cows (taken from Hoard's Dairyman), and also tables showing the records of a trial—at the St. Louis Fair of 1905—of Brown Swiss, Holsteins, Jerseys and Short Horns. The accom-

panying illustrations are of the best Jersey (Loretta D.) and the best Holstein (Shadybrook Gerben), at the Exposition, and of Yeksa Sunbeam (Guernsey), and Pansy of Woodroffe (Ayrshire).

A Wisconsin Guernsey.—Mr. Rietbrock's Yeksa Sunbeam (Plate I, Fig. 45) heads the list of officially tested cows. Her record for twelve consecutive months is 14,920.8 lbs. milk, and 857.15 lbs. fat, and is as follows :

Month.	Milk.	Per cent. fat.	Lbs. fat.	Total fat.
October	1428.2	5.69	81.26	—
November.....	1322.5	5.62	74.32	155.58
December.....	1294.4	6.08	78.70	234.28
January '05	1217.0	6.04	73.51	307.79
February	1060.8	5.75	61.00	368.79
March.....	1185.1	6.05	71.70	440.49
April.....	1089.6	5.79	63.09	503.58
May.....	1127.5	5.75	64.83	568.41
June.....	1158.4	5.25	60.82	629.23
July.....	1266.0	5.88	74.44	703.67
August.....	1463.8	5.42	79.34	783.01
September.....	1307.5	5.67	74.14	857.15

Yeksa Sunbeam, having given 14920.8 lbs. of milk, containing 857.15 lbs. fat, it follows that the average per cent. of fat in her milk was 5.744. Applying the Farrington scale to this quality of milk, we find that 100 lbs. of fat should yield $118\frac{1}{4}$ lbs. of butter, and consequently the 857.15 lbs. of fat would make 1013.56 lbs. of butter.

Yeksa Sunbeam was $9\frac{1}{2}$ years old at the commencement of the test. She was bred and reared by the late W. D. Richardson, at Garden City, Minn., and sold when a heifer to a milkman near Minneapolis, from whom she was purchased by Mr. Rietbrock. Her sire was Yeksa's Prince, a son of the cow, Yeksa, formerly owned by Mr. I. J. Clapp, Kenosha, Wis., and her dam was The Sunbeam, also formerly owned in Wisconsin by Prof. Haecker, before he went to Minnesota. There is, therefore, some poetic justice in her return to Wisconsin to make her phenomenal record.

In respect of feeding, I would say that during grazing season, the pastures of clover and blue grass were very good. We supplemented

this, during the fore part of last summer, with some clover hay fed in the barn, since the grass was very washy in the early part of the season on account of so much rain. During July and August we added to the pasturage a soiling ration of peas and oats, the peas being in a green state, the kernel formed in the pod, but not yet ripened, and fed it up to the time when the pea was quite hard, but will say that it was mostly during the period that we would call peas good to eat on the table as green peas.

In August and September, we also fed some green corn stalks. I cannot call it green corn, because there were no ears formed on it. It was from a planting made, about the 20th of June and close together.

During the late fall and winter of 1904, we also fed Yeksa Sunbeam, and some other cows, from 5 to 10 pounds of rutabagas. The roughage during the winter season was mostly clover hay. We fed also some alfalfa. I had 16 tons, and this was consumed by the calves, 10 to 12 in number, the 16 cows in the test and about the same number of other cows not being tested (the test cows got a larger allowance of alfalfa than the others).

During the winter, we also fed Yeksa Sunbeam from 25 to 30 pounds of silage. This silage had very little grain in it, since our corn did not mature very well last year, but it was succulent, good feed.

Now, as regards grain ration, we made a grain mixture composed of four parts wheat bran, two parts ground oats, two parts Buffalo gluten feed, one part Old Process oil meal. During part of the year we fed this oil meal in pea size—little kernels big as a pea. During the months of January, February and March, we added to this grain mixture one part of corn meal.

Of the above grain mixture, we fed Yeksa Sunbeam, during the months of October, November and December, 15 pounds a day. We reduced this by about 1 lb., feeding 14 lbs. a day, during January, February, March and April. For the month of May, we reduced her feed to 12 lbs. of the mixture and, as we got her on to the grass, and the grass improved in June, I think we reduced it still more. I find that a report has been made that she was fed only 6 lbs. of grain a day during June. I think 9 or 10 lbs. would be more nearly correct.

Fig. 75.—Yeksa Sunbeam (Guernsey), No. 15,439, Adv. Reg. 33r.



Helendale Stock Farm, Athens, Wis. (Fred. Riethock, Milwaukee, Wis.)

Fig. 76.—Shadybrook Gerben (Holstein).

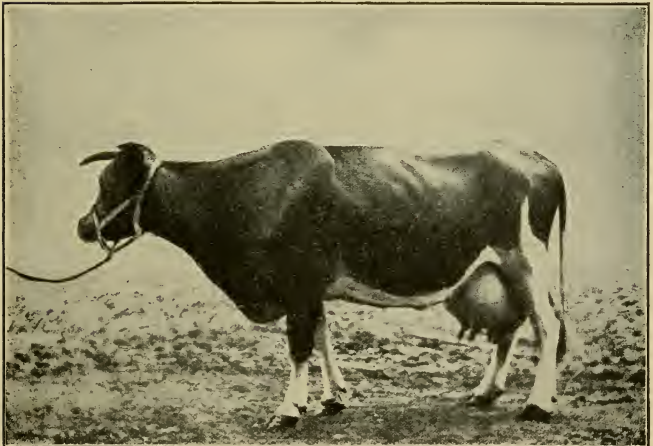

In 120 days produced 8101.7 lbs. milk; test 3.5 per cent. fat; butter fat 282.6; butter, 330.36 lbs.; weight, 1319 lbs.

Fig. 77.—Pansy of Woodroffe (Ayrshire), No. 18,915.

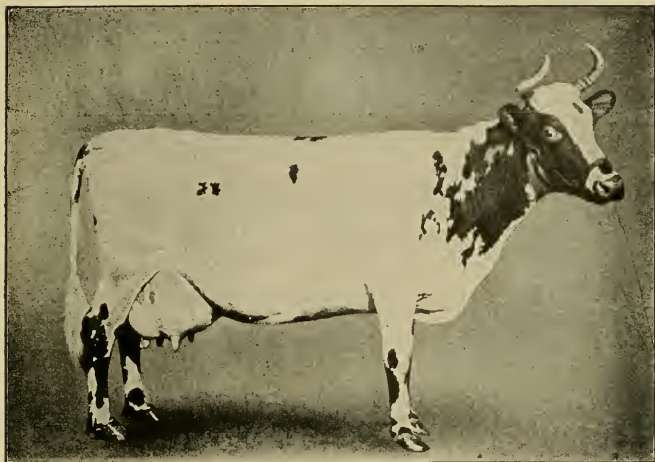

Champion at National Dairy Show, Chicago. (Property of Geo. Wm. Ballou, Middleton, N. Y.)

Fig. 78.—Loretta D. (Jersey).



During July, August and September of this year, she was fed daily a grain ration of the above mixture of 9 to 10 lbs. All these grain rations were fed in three meals, morning, noon and night.

RECORD OF THE BEST, POOREST AND AVERAGE COW IN EACH HERD FOR THE
120 DAYS AT ST. LOUIS FAIR, 1905.*

	Brown Swiss.	Holstein.	Jersey.	Shorthorn.
Milk per day, lbs.—				
Best cow	No. 1-51.0	No. 20-67.5	No. 37-48.4	No. 63-43.4
Poorest cow	No. 3-38.5	No. 7-47.1	No. 36-38.8	No. 62-21.4
Average cow	44.2	53.4	41.5	34.6
Test of Milk—				
Best cow	3.4	3.5	4.8	4.0
Poorest cow	3.8	3.2	4.1	3.9
Average cow	3.62	3.43	4.7	3.8
Butter fat per day, lbs.—				
Best cow	1.748	2.355	2.334	1.737
Poorest cow	1.477	1.507	1.615	0.843
Average cow	1.596	1.832	1.936	1.277
Butter per day, lbs.—				
Best cow	2.042	2.753	2.750	2.037
Poorest cow	1.731	1.756	1.898	0.988
Average cow	1.870	2.12	2.28	1.495
Solids-not-fat per day, lbs.—				
Best cow	4.363	5.171	4.357	3.720
Poorest cow	3.585	3.614	3.441	1.902
Average cow	3.919	4.239	3.634	2.980
Feed cost of milk, per qt. †—				
Best cow0109	.0090	.0110	.0109
Poorest cow0139	.0122	.0130	.0215
Average cow0124	.0107	.0116	.0132
Feed cost of butter, per lb.—				
Best cow136	.110	.097	.117
Poorest cow155	.164	.132	.234
Average cow147	.135	.105	.153
No. of cows in herd	5	15	25	28

* Illustrations and tables of records and rations from Dairy Cow Demonstration, at Louisiana Purchase Exposition, 1905. Edited by Prof. E. H. Farrington.

† Assuming two pounds to the quart.

ONE DAY'S RATION OF ONE COW IN EACH HERD AT ST. LOUIS FAIR, 1905.

Feed in Pounds.	Brown Swiss.	Holstein.	Jersey.	Shorthorn.
Alfalfa hay.....	7	—	18	9
Cut alfalfa hay.....	—	15	6	—
Corn silage.....	—	—	16	24
Green cut corn.....	40	15	—	—
Green cow peas.....	—	35	—	—
Wheat bran.....	—	2	3	4
Linseed (oil meal).....	—	—	2	2
Ground oats.....	—	—	2.5	2
Hominy feed.....	8	5	2.5	3
Gluten feed.....	—	—	5.0	2
Corn meal.....	—	—	1.5	—
Corn hearts.....	—	—	2.5	2
Cottonseed meal.....	1	1	—	2
Distiller's grains.....	—	—	—	4
Union grains.....	15	14	—	—
Total.....	71	87	59	54
Including grain.....	24	22	19	21

Such records as these are probably a revelation to many a man who has fed and milked cows for years. It is not customary to give more than five to ten pounds of grain per day to cows on the home farms, and the majority of them probably get less than five pounds. A capacity for assimilating large rations is necessary for producing large quantities of milk and butter, and most of these World's Fair cows were fed to their limit of endurance. A daily feeding per cow of near twenty pounds of grain, together with thirty to sixty pounds of green feed, was not uncommon, although there were some variations in the total amount during the 120 days of the test.

Dehorning Calves

It is now generally recognized that all milch cows should be dehorned, to prevent injury to themselves (in tearing off a horn, etc.), to other animals, to stables and to persons. As the operation of removing the horns from grown animals is unpleasant, and detrimental for the time to the patient, the following simple method,

recommended by the English Board of Agriculture and found successful in practice, should be followed in the treatment of calves :

“ Clip the hair from the top of the horn, when the calf is from two to five days old ; slightly moisten the end of a stick of caustic potash and rub the tip of each horn firmly for about one-quarter of a minute, or until a slight impression has been made on the centre of the horn. Repeat this two to four times at intervals of five minutes. If a little blood appears in the centre of the horn, after one or more applications, only one more slight rubbing with the potash will be necessary.

“ The operation should not be performed on a calf over nine days old. Caustic potash can be obtained from any druggist in the form of a white stick (about as large as a pencil), and when not in use should be kept in a glass stoppered bottle in a dry place. One man should hold the calf while another uses the caustic. Roll a piece of tinfoil or paper about the end of the stick of caustic to protect the fingers of the operator from contact with it. Do not moisten the stick too much or the caustic will spread around the horn and destroy the flesh. For the same reason prevent the calf from wetting its head for several days after the operation. Be careful to rub the caustic on the centre of the horn and not around it. Caustic potash is a poison and must be kept in a safe place.”

Management of Hand Separators

There is no higher authority on dairy matters than Prof. E. H. Farrington, of the University of Wisconsin Experiment Station, to whom we have had the pleasure of referring on several occasions in the previous pages. I can not do better than to quote the rules laid down by him for the management of hand separators.

1. Place the separator on a firm foundation in a clean, well-ventilated room where it is free from all offensive odors.

2. Thoroughly clean the separator after each skimming ; the bowl should be taken apart and washed, together with all the tinware, every time the separator is used ; if allowed to stand for even one hour without cleaning there is danger of contaminating the next lot of cream from the sour bowl. This applies to all kinds of cream separators.

3. Wash the separator bowl and all tinware with cold water and then with warm water, using a brush to polish the surface and clean out the seams and

cracks ; finally scald with boiling water, leaving the parts of the bowl and tinware to dry in some place where they will be protected from dust. Do not wipe the bowl and tinware with a cloth or drying towel ; heat them so hot with steam or boiling water that wiping is unnecessary.

4. Rinse the milk receiving can and separator bowl with a quart or two of hot water just before running milk into the separator.

5. Cool the cream as it comes from the separator, or immediately after, to a temperature near 50° F. and keep it cold until delivered.

6. Never mix warm and cold cream or sweet and slightly tainted cream.

7. Provide a covered and clean water tank for holding the cream cans and change the water frequently in the tank so that the temperature does not rise above 60° F. A satisfactory arrangement may be made by allowing running water to flow through the cream tank to the stock watering tank.

8. Skim the milk immediately after each milking, as it is more work to save the milk and separate once a day, and less satisfactory, than skimming while the milk is warm, since the milk must be heated again when saved until another milking.

9. A rich cream, testing 35 per cent. fat or more, is the most satisfactory to both farmer and factory. The best separators will skim a rich cream as efficiently as a thin cream and more skim milk is left on the farm when a rich cream is sold.

10. Cream should be perfectly sweet, containing no lumps or clots when sampled and delivered to the haulers or parties buying it.

There is a good demand for sweet cream and a perfectly clean, sweet and satisfactory cream can easily be supplied either to a retailer, an ice cream maker, or a creamery by keeping clean the separator, tinware, strainer-cloth and water tank, and the cream cold.

To Keep Records of Individual Cows.

Printed forms for making records* should be used. These consist of single sheets of stiff paper which are ruled so as to permit of keeping a record of the night's and morning's milk in pounds and ounces for one month, and also supply space to note the average per cent. of butter fat, if taken once or twice a month. One sheet may be used for 10 or 20 to 30 cows according to the size ordered.

Each cow must be named or numbered to use these sheets. The metal tags for insertion in the cow's ear are most suitable for numbering. As soon as each cow is milked the milk is poured in a special weighing pail and the weight is then recorded on the milk sheet. A spring scale sold for the purpose is most convenient. This is arranged so as to allow for the weight of the weighing pail in order that it will not have to be subtracted from the total weight of pail and milk at each weighing.

* Printed forms for keeping cow records are sold very cheaply by Hoard's Dairyman, Fort Atkinson, Wis.

The milk is poured back from the weighing pail into the milk pail, to mix it thoroughly, and a tablespoonful of the mixed milk is poured into a half pint bottle containing one corrosive sublimate tablet for preserving milk (to be had of any dairy supply company). The bottle should be corked and a similar sample of night's and morning's milk should be added to the bottle for three days to one week, the bottle being shaken each time new samples of milk are poured into it. The bottle is to be labelled with the cow's name supplying the milk. The milk in the bottle then represents that from a number of milkings from the same cow and is called a composite sample. The composite sample is tested for fat by the Babcock machine (see p. 193). The night and morning milk of each cow ought to be weighed and recorded at least once a week during the year and a fat test made from a composite sample twice a month, in order to determine thoroughly the value of a cow.

Value of Cows

I may be permitted to submit the following quotation in regard to the value of a cow :

“ The basis of valuation as set forth by Prof. S. F. Cooley, of Vt., is that a cow is worth, above what her carcass will fetch, the sum on which her annual profit will pay six per cent. interest, two per cent. taxes and insurance, twenty-five per cent. depreciation, or thirty-three per cent. total.

“ Twenty-five per cent. depreciation means a sinking fund which will pay for the animal in four years, and presupposes the average period of usefulness to be four years. On this basis, we get the following results in regard to the values of cows of different grades :

Kind of Cow.	Annual product lbs. milk.	Value of milk at \$1.50 per cwt.	Cost of feed.	Profit.	Value of cow.
Average.....	3,000	\$45	\$45	\$00	\$00
Fair	5,000	75	50	25	75
Good.....	7,000	105	60	44	135
Choice	10,000	150	75	75	225
Pieterje II.....	30,000	450	100	350	1,050

“ As a business proposition, the difference in value here represented appears correct. But the market does not so rate them. A

poor cow costs \$30 and brings \$25 in four years, during which time she sunk \$5 more than she had brought. An average cow is worth what her carcass will fetch, and no more. A fair cow costs \$35 to \$40 and leaves her buyer \$50 to the good, in four years. A good cow costs \$50, and you double on investment the first year. A choice cow costs \$75, and that is the amount of her annual profit. Pietertje II is worth \$1,000."

Plans of Barns and Milk Rooms

In the following pages will be found illustrated and described the stables and milk rooms of two farms supplying clean milk to Seattle, Washington.

The first farm is owned by J. D. Farrell, Esq., and is not conducted solely for profit or the support of its owner and may be regarded as one type of plant. The other is owned by W. H. Paulhamus, Esq., of Sumner, Wash. Mr. Paulhamus was the first to attempt to supply Seattle with clean milk and is shipping some thousand quarts a day from his own and three neighboring farms. His arrangements for handling the milk are therefore adapted to caring for a considerable quantity.

Mr. Farrell's stable for 40 cows has a floor, manure trench and feeding gutter of concrete with cement finish. The cows face toward a central feeding aisle. Behind the manure trench there is a walk five feet wide to the side of the building. The manure trench is eighteen inches wide. The length of the stalls is—from the front edge of the manure trench to that of the feeding gutter—six and one-half feet. The width of the stalls is thirty-nine inches for some, and forty-three inches for others, to accommodate Jerseys and Holsteins. The feeding aisle in front of the cattle is nine feet wide. The feeding gutter is also used for watering each time before feeding, when the water is let out. The height of the stable, on the sides, is seven feet four inches, and the ceiling is arched up toward the centre.

The walls and ceiling are double, with air-space between, and the ventilation is after the King system. The cement is brought up four feet on the walls, and the rest of the walls and the ceiling are of matched and planed boards, tightly fitted, and the whole painted white. The gutters for manure slope from six to ten inches deep at

Fig. 79.

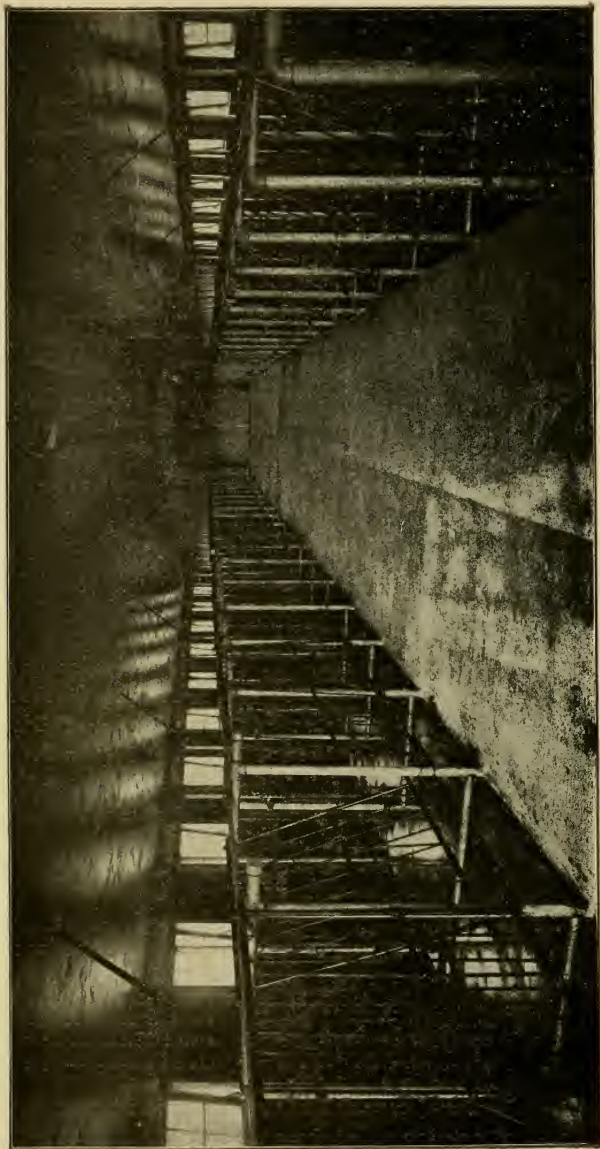

Showing stable. (J. D. Farrell, Esq.)

the lower end, and drain into pipes carried a considerable distance to a lower level than the stable.

Stalls.—The rear portion of each side of each stall is a gate. This gate is hinged and fastened as shown in plate. The dimensions of the gate are twenty-eight inches from top to bottom, and forty-four inches wide, and the lower edge is sixteen inches from the floor. The stationary front part of the side of each stall is thirty-four inches wide and fifty inches high, from top to floor. Its lower edge is ten inches from the floor, in the rear part, and two inches above the gutter for feeding in front. The feeding and watering gutter, of cement, is

Fig. 80.

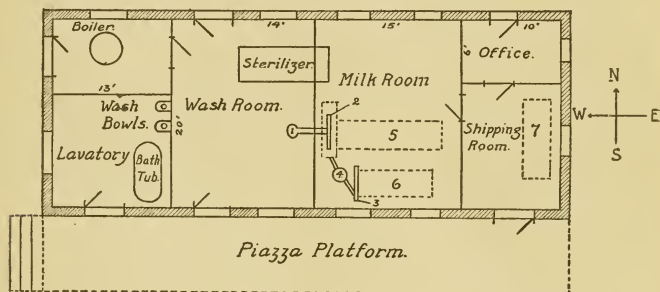

Sketch Showing Ground Plan of Milk House Owned by J. D. FARRELL, Esq., Renton, Washington.

eight inches deep and one foot wide. The gates forming the front of each stall are forty-two inches in their perpendicular measurement. They are adjustable and affixed to the top and sides of the stall by small chains with hooks on the end.

For the larger cows, the upper part of the gate may be tipped forward and fastened to an extension of the top rod forming the side of the stall (see Fig. 79). In the case of the smaller cows, the top of the gate is tipped backward toward the manure trench, crowding the cow back so as to make her stand on the edge of the manure trench (see Fig. 79).

The milk from the stable is brought into the wash room and is hoisted onto a raised platform and poured into a strainer marked (1).

from which elevation it flows into a funnel and conducting tube through the wall into the collecting tank for the Star cooler (2) and cream cooler (3). From this collecting tank a tube also supplies the separator (4), see Fig. 83. The raised platform shown in Fig. 81 was a mistake, as it should have been lowered so far as would permit a man standing on it to pour the milk into the strainer shown. It is much too high, and the platform—instead of requiring a ladder—would have only required a few steps leading up to it. The tank under the platform was intended to hold cracked ice, on which water was to be sprayed for supplying the ice water section of the Star cooler in summer. But this was found unnecessary, as a cask could be placed on the floor containing a coil of pipe to cool the water as described on p. 116. The numbers (5 and 6) in the milk room are supposed to represent the bottle filling apparatus for milk and cream shown in plate. The bottles, when filled, are kept over night in a series of tanks, one over the other (7), as water is had from a neighboring spring at a temperature of 46 deg. F. to fill the tanks. The bottles are shipped on ice in galvanized iron cases. The empty bottles are delivered on the elevated piazza platform, in front of the wash room, and the bottles and all the milk utensils are washed, put in the sterilizer and taken out through the other door in the milk room when it is desired to use them. The milk room is only connected (with one door) with the shipping room and is ventilated by a system similar to that recommended for barns. The floors of all the rooms in the milk house are of cement, and the walls of cement-plaster, covered with many coats of white enamel paint. The cement-plaster is laid on wooden laths and the construction of the building is of wood. It is steam heated in the lavatory and wash room. The climate is very mild hereabouts and rarely gets much below freezing.

Sketches of the barn and milk house owned by W. H. Paulhamus, Esq., are reproduced here with the hope that they may prove of practical value to those intending to handle clean milk on a considerable scale for profit.

The barn (Fig. 84) is built of wood and ceiled within with smooth, matched boards (shiplap) painted with cold water white paint. The space between the outer and inner boarding of the walls is filled in with sawdust. The inside of the barn is eleven feet high,

Fig. 81.



Showing Stable. (J. D. Farrell, Esq.)

Fig. 82.



Showing Washroom. (J. D. Farrell, Esq.)

Fig. 83.

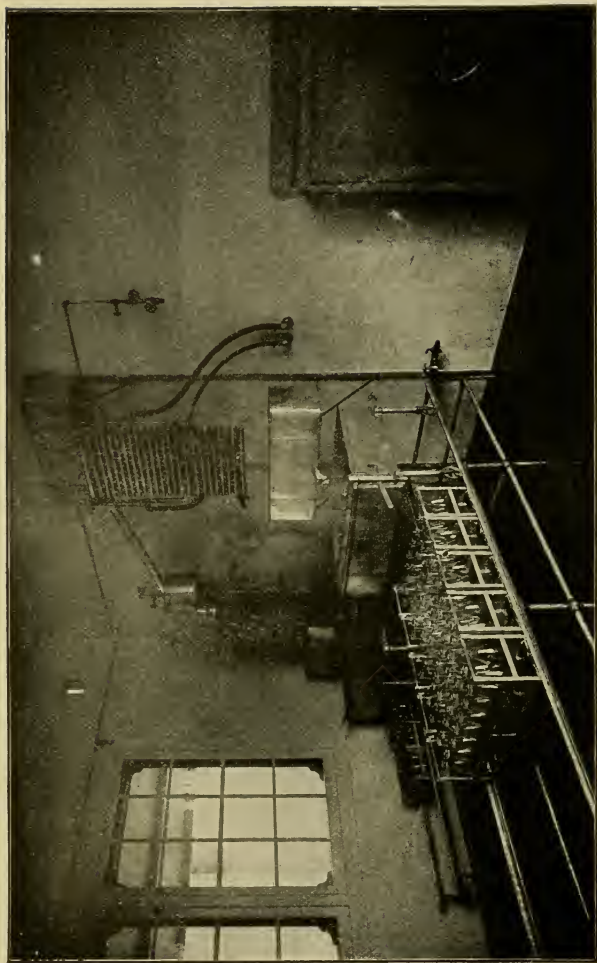

Showing Milk Room (J. D. Farrell, Esq.)

Fig. 84.—Interior of the Paulhamus barn.

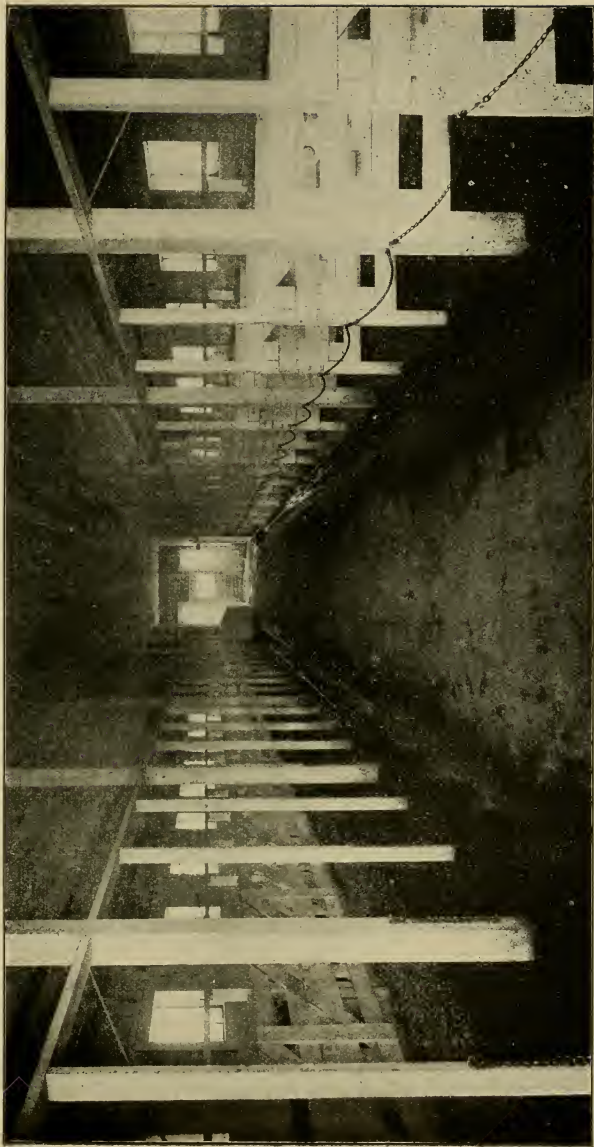

The photograph shows cement alley and gutters between the rear of the cow stalls, the cows facing outward. The cement is carried only 8 inches on the floor of the cow stall, the cows lying on wood. For description, see p. 326.

building (7) and are two feet square with openings at the floor of the same dimensions.

One special feature is the arrangement of the cement which covers the whole floor, except as noted. The entire floor slopes about one foot from one end of the building, so, while the gutters are the same depth, this permits of a flow for drainage. The cows face the outside of the building and the floor of their stalls is of two inch matched, planed Oregon pine, except for a strip of cement eight inches wide on the side of the gutter (6) on which the hind feet of the animal rest. All the rest of the floor back of the cows is of concrete with cement finish, while the side aisles in front of the cattle are of wood, like the floor of the stalls. The cows do not have the slippery, cold, cement floor to lie (or fall) upon, which Mr. Paulhamus believes an improvement over an entire cement floor. The stalls are shown in Plate IX. There are so many kinds of stalls that it is impossible to say which is the best, but these are simple, inexpensive and satisfactory, as soon as the cows get used to them.

At one end of the barn are several rooms. One (1) is intended for keeping supplies, as baled hay, roots and grain in sacks, etc. One on the opposite side is a wash room with sink and hot and cold water (B), and a sheet iron stove (A) for wood with a coil of pipe inside to heat water (see p. 120). There is also a closet (*d*) for keeping the milking clothes. The next room (3) is a rather novel arrangement of the owner and assuredly deserves attention.

This room has no connection with the inside of the barn, except by a tube for conveying milk at C. Here may be found a pair of steps which each milker ascends the moment he fills the pail. The milk is poured into a sterile tin funnel which carries it onto a Star cooler*, from which it falls, immediately cooled, into a can. The can, when full, is taken to the milk house (Fig. 87), some 200 feet away.

The room (3) is reached from outside the barn and—with screened door and window, and smooth, clean, painted walls and ceiling, and

* The milk flows from the funnel (which is in the open central aisle of the barn) through the wall, which separates it from room 3, and in that room falls on the cooler.

Fig. 86.

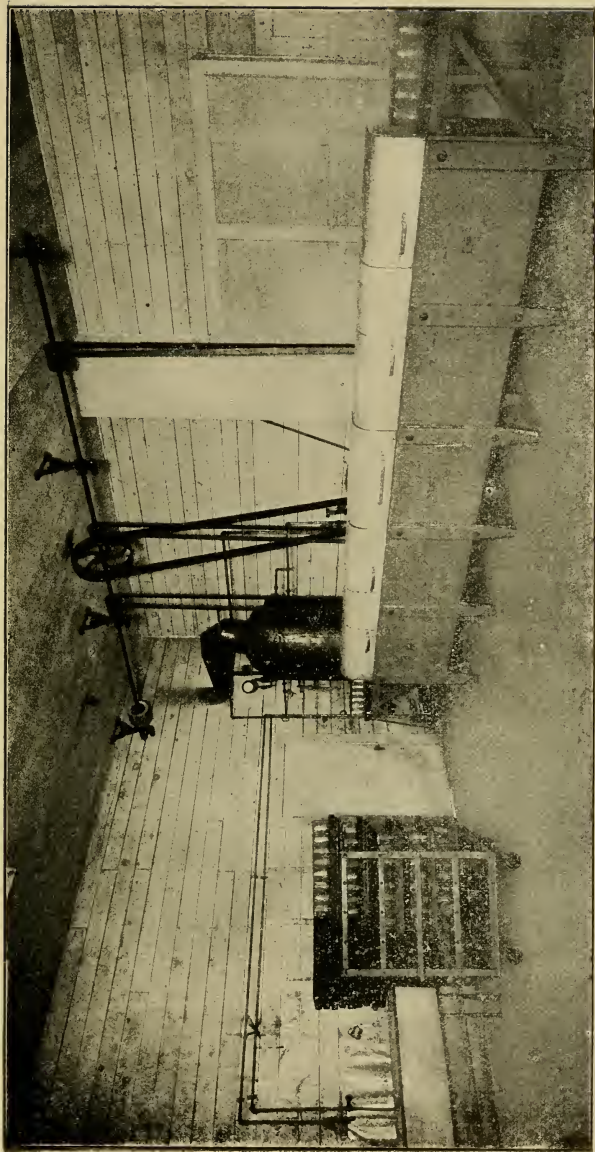

Showing bottle-washing machine at the Paulhamus farm. The milk bottles are pushed through on a track, entering on the extreme left and coming out at the extreme right of the machine, as seen in the picture. The metal hood on top of the tanks prevents the water, spraying the outside of the bottles, from being scattered about the room. For description, see p. 350.

cement floor—makes a good place for immediate cooling of the milk. The horizontal ceiling of the barn leaves much space in the roof, in which grain is stored. The grain is brought down in spouts to the bins at (2) and hay could be delivered from the loft above in the room (1) without causing any dust in the barn. The ceiling of the barn is absolutely dust tight with double floor and paper between.

The barn is one hundred by thirty-five feet inside; the centre

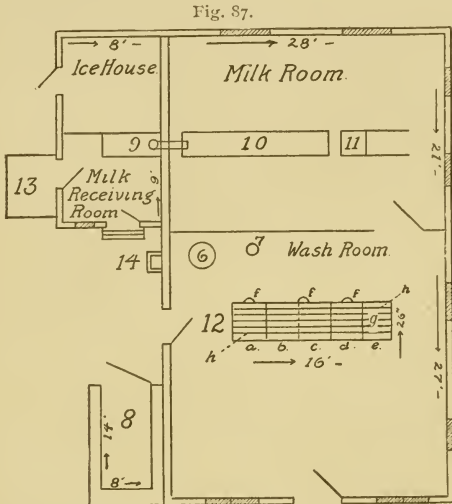

Rough Sketch of Ground Plan of Milk House. W. H. PAULHAMUS, Esq.,
Sumner, Washington.

aisle eight feet, and gutters eighteen inches wide. The side aisles are five and one-half feet wide.

Box stalls for sick cows, or cows about to calve, are in another building.

The buildings used for the milk rooms (Fig. 87) proper were altered for their present purpose and were situated farther from the barn than is necessary or desirable.

A sketch of the ground plan of the milk house is shown in Fig. 87.

The floors of the milk room and wash room are of concrete with

cement finish, boarded inside with planed, matched boards (walls and ceiling), painted white and ventilated after the King system. The space between the inner and outer layer of the walls is stuffed with sawdust and the rooms are very high-studded (fourteen feet). The sterilizer (8) is wholly of concrete, which is described on p. 127, and, if the buildings had not been already built before they were put to their present use, it is probable that the most convenient place for the sterilizer would have been in the wall between the wash and milk rooms, as in Mr. Farrell's (Figs. 82 and 83). The sterilizer is supplied with steam from the 20-horse power boiler (6) in the wash room.

This sterilizer is an original feature introduced by Mr. Paulhamus and works beautifully. It is of enormous size (see p. 127 and Fig. 88) and very inexpensive, costing some \$80. In cold climates it would have to be inside the building as suggested above. Another novel feature is the washing machine shown as (No. 12) in the sketch in the wash room. This was patented after its introduction at Mr. Paulhamus's farm and now sold by The Chas. H. Lilly Co., of Seattle. The machine consists of four tanks, *a*, *b*, and *c*, *d* and *e*. In *a*, is held warm water, in *b* and *c*, is contained alkali and warm water, and in *d*, is plain warm water. The three lines (*g*) running lengthwise in the sketch, through the middle of the machine, represent three pipes running over the top of the tanks. These pipes are perforated with holes which are placed so as to correspond with the opening in each milk bottle when the bottles are inverted on wooden trays. Each wooden tray is made of slats which, in crossing, leave holes fitting the neck of an inverted milk bottle. The trays holds twenty-four bottles in three rows, so that when the tray is slid in place on top of the machine, each row of bottles is over one of the three pipes in the centre of the machine, and each bottle is inverted over one of the perforations in the pipes. On one side of the machine are three rotary pumps (*f*) worked by the engine at (7). These continually pump water from the tanks into the the pipes, from which it is forced out in jets into the interior of each inverted milk bottle. The water then runs out of the bottles back into the tank over which the bottles are resting. The pipe shown on either side of the top of the machine at (*h*) is perforated with holes from which water is thrown over and cleans the outside of the bottles as they are pushed through the machine.

Fig. 88.



This photograph shows the interior of the large all-concrete and cement sterilizer at the Paulhamus farm. The door is of iron. All the dairy utensils which come in contact with milk in any way are put in this chamber and kept at 212° F for one hour daily. For description, see p. 127.

The method of working is as follows: A tray holding twenty-four inverted bottles is placed on the top of the machine over the tank (a). The warm water in the central pipes is pumped up through the holes in the pipes into each bottle, thus rinsing it out. Another tray being pushed into the machine shoves the first tray over tank (b). Here the interior of the bottles is sprayed with lye and water. The introduction of another tray moves the first tray over the tank (c). The tank (c) is really one with (b), the bottles here merely draining back into the tank again, no water being pumped into them. Another tray being placed in the machine pushes the first tray to (d). Here the bottles are rinsed with plain warm water to remove the lye, and, at (e), boiling water is injected instead of water to sterilize (for one minute) the bottles. About 1,500 bottles may be washed in one hour by this labor-saving device. The bottles must, however, be washed by hand if they contain old milk and have not been previously rinsed by the milk consumer. Also, one minute sterilization* is not sufficient and they must go for one hour's sterilization in the large sterilizer, when certified milk is desired. The water is heated by steam from the boiler (6) which runs the engine. A metal hood covers the whole top of the washing machine to prevent the escape of the water which is thrown from the pipes on each side over the exterior of the bottles. The machine with pumps costs about \$200, and is sixteen feet long and twenty-six inches wide (see Fig. 86).

The platform (13) and floor of the milk-receiving room are some fifty inches from the ground. In the milk-receiving room at (9) is a raised platform three feet from the floor on which are scales holding a large milk-receiving tank in which is a Star trap strainer. After the milk is weighed it is run from a faucet into a funnel, conducting the milk through the wall, into a tank (10) holding some one hundred gallons, and from thence is drawn off into the Star bottle filling tank (11). The milk is cooled, as described, at the barn (p. 328), and the water supplying the Star cooler is cooled in summer by running it through a coil of pipe in a cask of ice water (see p. 116).

* It is perfectly possible to sterilize milk bottles absolutely, if boiling water is pumped into the bottles for a longer time, as shown by bacteriological examinations of bottles washed by similar machines. The exhaust steam from the engine may be used to heat water to boiling point.

A sketch of the cow stall used by Mr. Paulhamus is shown in Fig. 89.

The floor has been described (p. 328) as consisting of cement for eight inches in front of the gutter and (forward of this point) of two inches kiln-dried, planed, tongued and grooved Oregon pine. The dimensions are marked in the sketch, but the length of the stalls vary

Fig. 89.

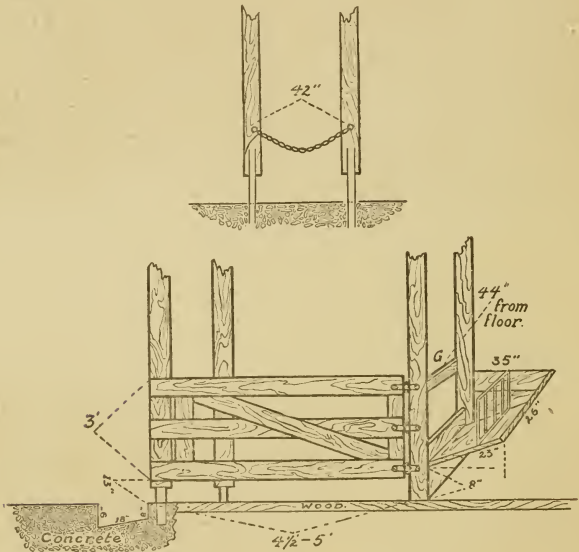

Side and Rear View of Stall in Cow Stable of W. H. PAULHAMUS, Esq.,
Sumner, Washington.

from four and one-half feet to five feet long, from the gutter to the manger, to accommodate cows (Jerseys) of different sizes. The floor of the stall slopes some three inches from front to rear. The stalls begin four and one-half feet long at one end of the stable and gradually lengthen till they are five feet long at the other end. Each side of stall is really a gate opening toward the right, to give more room to the milker and groomer, when open. They could of course be hung on hinges so as to swing in either directi...

Fig. 90.—The improved "Drown" Stall.

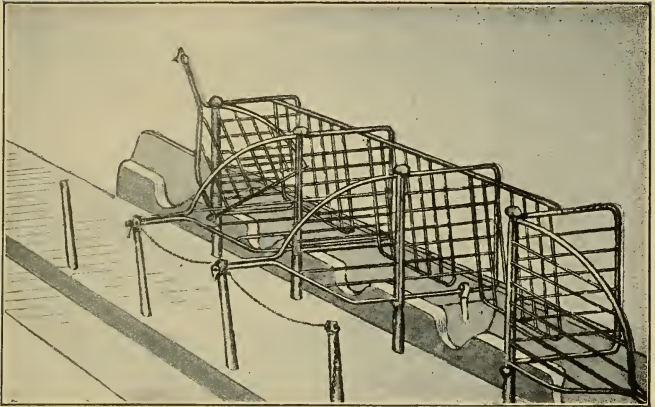

View shows cement mangers and floors fitted with iron stalls having two-way movable partitions.

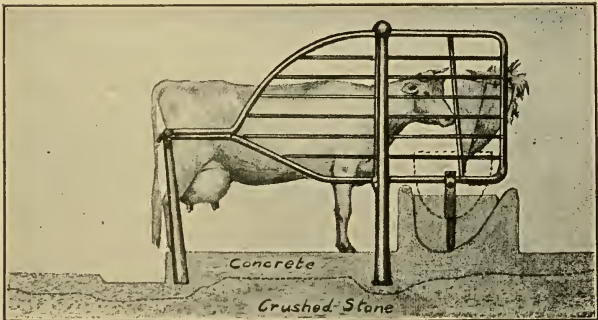

The Drown Stall is one of the best made and is an improvement over either stall shown in that the side gates give more room to the attendant and open in either direction sideways and also upward. The raised feeding trench and hay rack are good features.

The stall is patented and sold by M. L. Drown, of Madison, Wis. It is in use by some of the agricultural experiment stations and leading dairy farmers of this country.

The gates are fastened with a wooden sliding bolt (not shown). The bottom of the rear posts may (for the lower eighteen inches) consist of galvanized iron pipe set below in the cement and above in the wooden scantling, for the sake of cleanliness. At the rear of the stall is seen a chain which is attached to rings in the post, on either side of the stall, by means of snap hooks. The manger has two compartments, the lower for grain, and the upper or forward being for hay—with a sliding rack between the two which may be removed or lifted a little to clean out the floor of the manger. (Sometimes the whole manger, arranged with sides reaching to the floor of the stable, is made movable so that it may be adjusted to the length of the cow and locked by pegs fitting in the side posts.) The cross-piece at (C) is necessary to keep the cows from pressing forward and climbing over the manger. It must be adjusted somewhat to the height of the cow. This stall is convenient and inexpensive as compared to the iron stalls (Figs. 79, 81). There is nothing on the floor of the stable to collect dirt, as the manger does not touch the floor, but is eight inches above it.

We present a method of fastening cows (Fig. 91) without the use of stalls. In this the animals are tied by swing stanchions. These are greatly superior to the old style of fixed wooden stanchions in allowing free movement of the cows. No partition is used between the cows' bodies, but one, as seen in the cut, is placed in the feed trough separating the cows' heads. It has the advantage of being a simple, cleanly, compact and cheap method of housing cows. Compact and cleanly in avoiding gates between cows, which collect dirt, it has the disadvantage of not keeping the cows so well separated as when there is a partition between each animal, and it can not be arranged to conform to the length of each animal as can stalls with a movable gate in front of each cow. It is widely used and by many good authorities is regarded as the best method of fastening animals in the barn.

The feed trough or manger is seen to be hollowed out of cement, with cement partitions in it between each cow. On top of each cement partition is one of wood, to which water buckets may be attached. The wood base of the stanchions should not rise above the level of the cement floor in order that sweeping and cleaning can be

more readily done. In the upper part of the cut is seen a cross section of a barn floor arranged for two rows of cows facing one another. The feeding alley between the two rows of cows is nine feet wide; the feeding trough is two feet wide; the length of the standing space for the cows is five feet six inches (varying with the size of the:

Fig. 91.

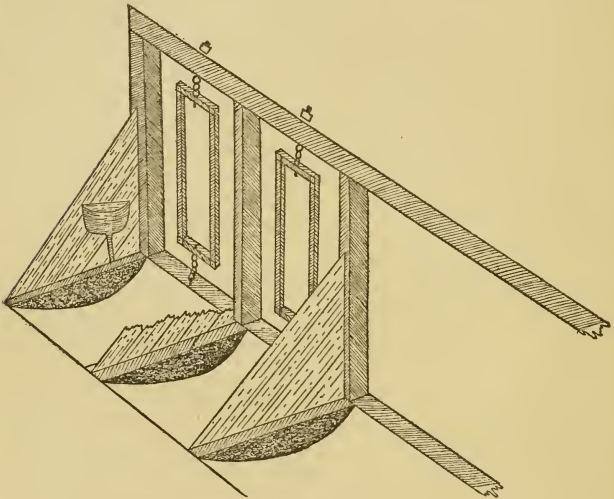
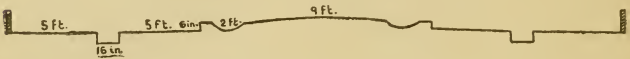

Swing Stanchion and Cross Section of Feed Trough.

(From Bull. No. 53, Storrs Agricultural Experiment Station.)

cows); the manure trench is sixteen inches wide; the alley behind the cows is five feet wide.

Another arrangement for swing stanchion; fixed, iron partition; and removable, wood, paneled floor over concrete is shown in the accompanying cuts (Fig. 92).

These and the following plans for milk rooms, a creamery and

city milk plant, and a creamery for whole milk, are taken from Bull. 104, U. S. Bureau of Animal Industry.

Fig. 92.

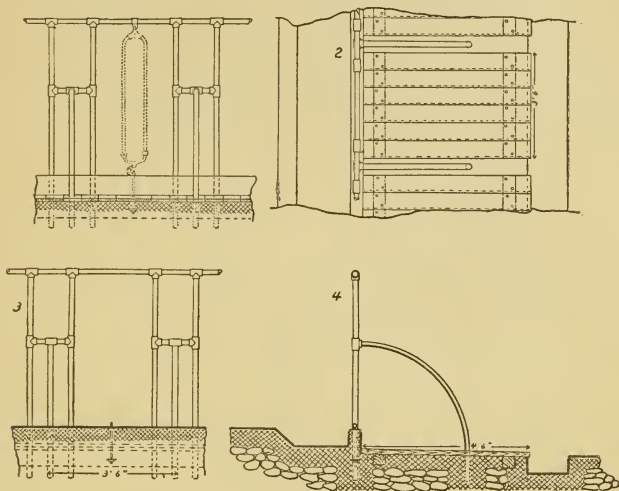

Stall with panel wooden floor.

1. Swing stanchion. 2. Showing wooden floor, viewed from above. 3. Stall from the front. 4. Side view of stall and cross section of floor.

Fig. 93.

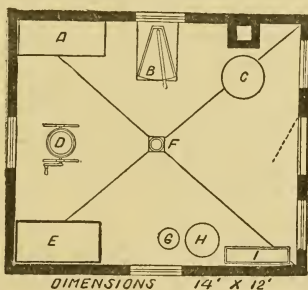

Shows a small dairy house suitable for the general needs of a herd of 25 to 30 cows. *A* is the ice box; *B*, butter worker; *C*, heater; *D*, churn; *E*, cream vat; *F*, trap to sewer; *G*, cooler; *H*, separator; *I*, can and pail rack. If this house is built of wood, the brick chimney should be built outside the frame.

Fig. 94.

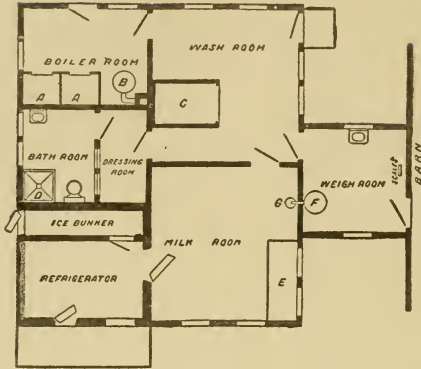

Floor plan of small plant for certified milk connected with barn. *A A* are coal bunkers; *B*, boiler; *C*, sterilizer; *D*, shower bath; *E*, bottling table; *F*, cooler; *G*, receiving can.

Fig. 95.

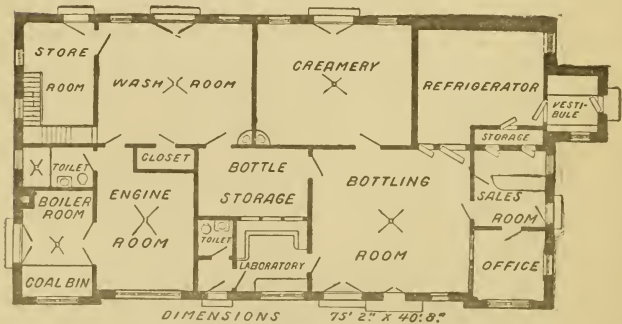

Floor plan of creamery and city milk plant.

Fig. 96.

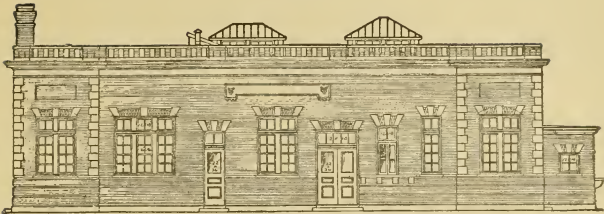

Front elevation of creamery and city milk plant shown in Fig. 95.

Fig. 97.

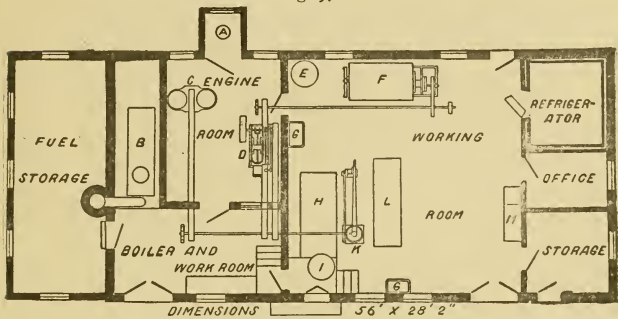

Floor plan of creamery for whole milk.

In the plan as shown *A* is the pump; *B*, boiler; *C*, ice machine; *D*, engine; *E*, skim milk weigher; *F*, churn; *G*, sink; *H*, milk vat; *I*, weighing tank; *K*, separator; *L*, cream vat; *M*, table.

Concentrated Milk

This is a new product, made by a patented process, whereby the cream is separated from the milk and pasteurized, while the skim milk is heated for two hours at 140° F. and reunited with the pasteurized cream. The resulting concentrated milk is used by diluting it with three parts of water.

When thus diluted it appears to have the taste, appearance and all the properties of ordinary fresh milk. It is, however, free from all disease-producing germs, including those causing the infectious and diarrheal disorders and tuberculosis.

The reason of its unaltered taste and physical properties lies in the low temperature (140° F.) at which it is pasteurized, and the

reason for the effective destruction of disease germs is due to the long period of heating (two hours).

Concentrated milk is of small bulk and may therefore be transported cheaply. It must, however, be kept at 50° F., and even at this point germs may become abundant after a few days. Thus, Conn states, after six days concentrated milk may contain a number approaching 500,000 bacteria to the cubic centimeter—even though it be kept cool. These bacteria are harmless and the milk is not soured.

Concentrated milk, when properly diluted (1 to 3), will cost the consumer just about what ordinary fresh milk does.

It is, nevertheless, extremely doubtful whether concentrated milk will supersede fresh, clean milk, although it is a great improvement over dirty milk. My reason for this assumption is that milk is taken largely in the household for its cream, for use on the table and for infant feeding.

All handling of milk disturbs and lessens to some extent the complete rising of cream. When milk is simply cooled and bottled at the farm, the cream has already completely separated when it reaches the consumer's house (in most cases), and may be immediately removed for use. This statement cannot be applied to concentrated milk.

Milking Machines.

The milking machine, together with the single service paper milk bottle, bid fair to practically revolutionize the methods of producing clean milk.

If these two inventions prove as valuable as they promise, the whole question of clean milk production will be solved. The milk will be obtained nearly sterile and be immediately cooled and run into sterile bottles. The status of the milking machine seems still a matter of some uncertainty with every indication of a successful future. The machine we will describe appears to be one of the most efficient and has been in operation for some years. At present it is being used by the leaders in the dairy industry, as by the Walker-Gordon people.

The Burrell-Lawrence-Kennedy Cow Milker comprises the following :

1. A vacuum pump operated by power, steam, electric motor, gas engine, tread mill (bull), a head of water over thirty feet, etc.

2. One inch iron piping connecting the vacuum pump with a vacuum tank, supplied with gauge and safety valve, and thence about the barn for attachment to the milkers.

3. *The Milkers.*—A milker consists of a milk pail (heavy enough to withstand a vacuum), on which is placed a pulsator, which in its turn is connected with one-half inch rubber tubing to four teat cups fitted on the teats of the cow.

The vacuum is about equal to one-half an atmosphere, fifteen to seventeen inches, and the vacuum tank is connected with the system to insure a uniform, safe and known suction. The pulsator (Fig. 99) is the salient feature of this machine. It rests on top of the milk pail, to which it fits tightly as soon as the exhaust is turned on, because of atmospheric pressure and because it rests on a rubber gasket. The pulsator is connected with the iron pipes which run along over the stanchions (Fig. 98) by one-half inch rubber tubing fitted to the nipple at its base. The two stop-cocks, seen in the plate of the pulsator, are each connected with rubber tubes, one taking the milk from the four teats of a cow on one side, and the other from the cow to the other side of the pulsator.

When the machine is in operation the cow's udder is cleaned, the teat cups (of five sizes) are adjusted, and a milk pail—placed between each two cows—is surmounted by a pulsator attached by rubber tubing, both to the iron piping above, and to the teats of the cows on each side (Fig. 98). That is, each milker (milk pail, pulsator, rubber connections and teat cups) is capable of milking two cows at the same time. A stop-cock is turned and the suction applied by the pulsator to the cow's teats. By this mechanism there is exerted intermittently not only suction but also compression on the outside of the teat, simulating the action produced in hand milking. Glass windows in the tubing leading from the teats inform the operator as to the flow of milk. Most cows do not object to the use of the machine.

This machine will practically prevent the initial contamination of milk, and will render the production of clean milk more simple and easy than by any method heretofore known. But the greatest care is necessary to achieve this result.

Stocking and Mason* have made elaborate experiments to determine the best way to cleanse and sterilize the rubber tubing and teat cups of milking machines. They found that bacteria multiply rapidly in ten per cent. brine solution, which has been commonly used. Continuous sterilization of rubber by boiling water or steam for a proper period to sterilize is destructive to the rubber parts. The method finally adopted was to first rinse the tubing and teat cups with clean water after each milking. This is done by connecting the machine to the vacuum system near a sink, and, by plunging the teat cups in the sink, clean water is drawn through the teat cups and tubing into the milk pails. The next step consists in soaking the teat cups and rubber tubing in a $3\frac{1}{2}$ per cent. solution of formalin in water between milkings. Just before milking the rubber tubing and teat cups are again thoroughly rinsed in clean, boiled water. The milk pail and pulsator are sterilized by steam in a sterilizer or by boiling in water.

By the above method the bacterial content of milk withdrawn by machine was about the same as that obtained by hand under cleanly conditions in the same stable. In order to secure the best results a thin layer of absorbent cotton is placed in the air-relief of the teat cup connector and of the head of the machine to filter the bacteria from the stable air. At these two points the air rushes in at each pulsation of the machine to relieve the vacuum. After doing this the bacteria in the machine-drawn milk (averaging 1,578 bacteria per c. c.) were reduced to about one-third of those in the milk drawn by hand (averaging 4,560 bacteria per c. c.) under like conditions. The milk from the milking machine kept twice as long as the milk withdrawn by hand, *i. e.*, milk at 72 degrees soured after 38 hours when withdrawn by hand; machine-drawn milk kept sweet for 72 hours.

The only objection to the use of formalin in keeping the parts of the milking machine clean is the possibility of milk being contaminated by a trace of it. The presence of formalin in milk is illegal and would prove to be the greatest misfortune to one supplying a high grade of milk, as suggesting the possibility of intentional

* Storrs Agricul. Exper. Sta. Bull. 47, May, 1907.

Fig. 98.—The Burrell-Lawrence-Kennedy Cow Milker.

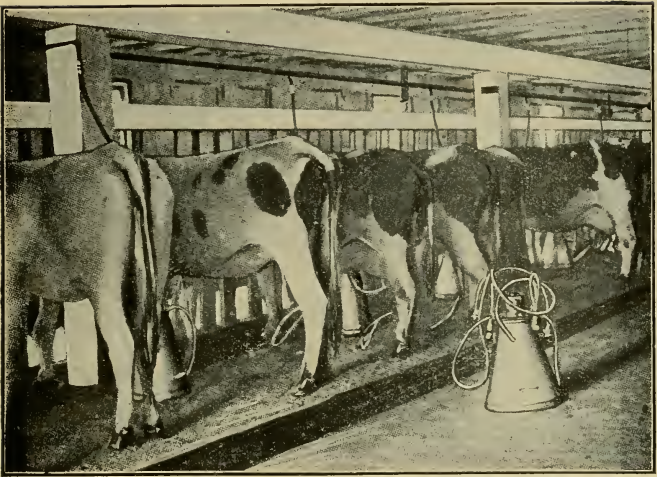

The plate shows the main iron piping above the stanchions connected by rubber tubing with the pulsators placed on top of each milk pail between each two cows.

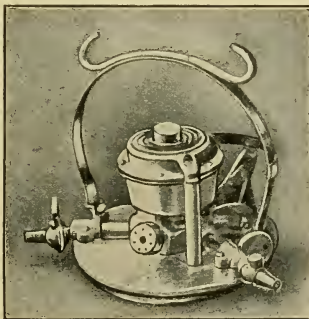

Fig. 99.—The Pulsator.

Fig. 100.—Illustrating the Hegelund method of milking.

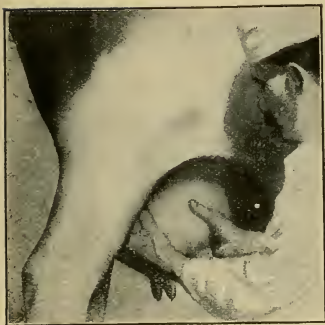

FIG. 1.—First manipulation of udder, right quarters.



FIG. 2.—First manipulation, left quarters.



FIG. 3.—Second manipulation, right fore quarter.



FIG. 4.—Second manipulation, right hind quarter.



FIG. 5.—Second manipulation, right hind quarter, rear view.



FIG. 6.—Third manipulation.

adulteration with this preservative. Stocking found no trace of formalin, however, in milk obtained from milking machines thus treated. From the viewpoint of this book the chief benefit of milking machines is the lowering of the germ-content of milk made possible by them. But this result has been by no means always secured and can not be unless the greatest care is given to the cleansing of all the parts.

As a labor-saver the device enables one man to do four men's work. One man can operate three or four milkers at once, each milking two cows at the same time, which means that he can milk thirty to forty cows an hour. With hand-milking this number of cows would require the work of four men for one hour.

Moreover, the results are much more uniform, and daily variations in milk-yield, depending on the personality of the milker, are eliminated.

The difficulties in keeping milkers and the disastrous results from frequent change of milkers are also removed by the machine.

Cost.—The expensive parts of the milking machine are the milkers and the vacuum pump, each of these costing \$75 apiece. This pump is capable of operating five milkers. The entire cost of the installation, power and milking machines is estimated by the sellers to amount to about \$12.00 per cow for a herd of forty cows, and \$8.50 per cow for a herd of seventy-five.*

With accumulating experience, the results obtained by the use of the Burrell-Lawrence-Kennedy milking machine appear to be generally favorable.

The more common doubts as to the amenability of cows to the milking machine, and the danger of drying up cows from incomplete emptying of the udder, have been dispelled. Cows hitherto unruly to hand milking, and heifers never milked before, have taken most kindly to the machine, and, on the whole, cows like machine milking better than hand milking.

Experiments appear to show that the milk yield is about the same in hand milking and machine milking, providing that the teat cups

* For details consult D. H. Burrell & Co., Little Falls, N. Y., and Brockville, Ont.

are carefully fitted. Also the udder appears to be emptied even more thoroughly by the machine than by hand—exclusive of stripping. The chief objection to the machine is its initial expense, while, on the other hand, its chief value lies in its saving of money and labor in its operation.

Hand stripping—after the removal of the teat cups—is done, generally, into the teat cups themselves. Cows which are milked by the machine have a longer period of lactation than when milked by hand.

What appeared a serious objection to the milking machine was the complaint that the milk of single cows could not be separated from that of the herd—in case it was contaminated with blood or pus and germs from an inflamed udder; or the milk was needed for feeding a calf; or for making a periodical test for quantity and fat. Gurler has obviated this defect by having the pail of one machine divided into two compartments, one for each cow, and provided with corresponding outlets from which the milk from each cow can be drawn. Garget, and all troubles with the udder, are less frequent with the milking machine—probably because the teats are not so subject to abrasions and infection from other cows by the hands of the milker.

Mr. H. B. Gurler, of Illinois, one of the most noted dairymen of this country—writing in *Hoard's Dairyman*—says that in thirty comparative tests between hand and machine milking, the number of bacteria was reduced one-half by the machine—from 5,000 to 2,500 per c.c. After fourteen months' use of the Burrell-Lawrence-Kennedy machine with two hundred cows he found but two or three cows which could not be milked by it; he gives it his unqualified approbation and affirms that it has come to stay.

Gurler states that one man with the machine is equal to three hand milkers; that no difficulty was experienced in keeping the apparatus clean by the use of rinsing in cold water, a solution of lye, and boiling water; and that great care should be taken in accurately fitting each teat cup to each individual teat. He warns against completely filling the milk pails, lest milk be drawn into the vacuum pipes, and emphasizes the necessity of a uniform vacuum. If a teat cup pulls off or any accident occurs which reduces the vacuum, the

machines should be shut off till the proper vacuum is secured. And when one of a pair of cows attached to a machine is milked before the other, the vacuum should be shut off from that cow, at the machine, and the machine kept running until the other cow is milked.

Smaller teat cups must be fitted on the cows after they have been in use for some time, as the rubber mouthpieces expand and teats grow smaller after freshening of cows.

Separate stalls for milking by the machine may be placed in the basement of a stable. The cows run loose and are turned into the stalls and are fed grain there as they are milked. When the milking is over the cow passes out of a gate in front of the stall. So no time is lost if one of a pair of cows is milked before the other. A small platform set between each pair of cows affords a base for the milking machine and a seat for the operator in adjusting the teat cups.

The machine is indicated for farms with a large number of cows (fifty or over) and where labor is expensive and difficult to obtain.

The Hegclund Method.—Extensive experiments with this method of manipulating the udder at the close of milking have been conducted by Woll at the University of Wisconsin Agricultural Station,* on one hundred and fifty cows during a summer and fall, and have proved its advantages to be as follows :

A daily gain of one pound of milk, and one-tenth pound of fat per cow was obtained. This is equivalent to a gain of about thirty-five pounds of butter per cow per annum.

Most cows do not object to the manipulation ; less than a dozen out of the number tested did so.

The gain in quantity of milk and fat is not a temporary increase ; not only is the gain persistent, but the method tends to maintain a large flow of milk during the lactation period.

The method taking the place of stripping, there is no loss of time in performing it.

The use of the method develops the milk-yield of heifers, and has even doubled that of cows which have been supposed to have reached their maximum flow of milk. It increases the fat in the milk so that

* Univ. Wis. Agric. Sta. Bull, No. 96.

the yield from this method contains ten per cent. of fat. It is of great value in preventing mastitis during the early period of lactation.

As the method has been adopted by some of the most progressive farmers in Denmark and this country, it is well worthy of trial and is herewith described.

DESCRIPTION OF THE MANIPULATIONS IN THE HEGELUND METHOD OF MILKING.

First Manipulation.—The right quarters of the udder are pressed against each other (if the udder is very large, only one-quarter at a time is taken) with the left hand on the hind quarter and the right hand in front on the fore quarter, the thumbs being placed on the outside of the udder and the four fingers in the division between the two halves of the udder. The hands are now pressed toward each other and at the same time lifted toward the body of the cow. This pressing and lifting is repeated three times, the milk collected in the milk cistern is then milked out, and the manipulation repeated until no more milk is obtained in this way, when the left quarters are treated in the same manner. (See Fig. 100, Figs. 1 and 2.)

Second Manipulation.—The glands are pressed together from the side. The fore quarters are milked each by itself by placing one hand, with fingers spread, on the outside of the quarter and the other hand in the division between the right and left fore quarters: the hands are pressed against each other and the teat then milked. When no more milk is obtained by this manipulation, the hind quarters are milked by placing a hand on the outside of each quarter, likewise with fingers spread and turned upward, but with the thumb just in front of the hind quarter. The hands are lifted and grasp into the gland from behind and from the side, after which they are lowered to draw the milk. The manipulation is repeated until no more milk is obtained. (See Fig. 100, Figs. 3-5.)

Third Manipulation.—The fore teats are grasped with partly closed hands and lifted with a push toward the body of the cow, both at the same time, by which method the glands are pressed between the hands and the body; the milk is drawn after each three pushes. When the fore teats are emptied, the hind teats are milked in the same manner. (See Fig. 100, Fig. 6.)

Standardizing Milk

It may be desirable to produce a milk standardized to contain a fixed and constant percentage of fat. This is particularly important for infant feeding. Or one may wish to supply a milk of unusual and definite richness; or again one may want to combine two lots of cream of different fat percentages to obtain a cream of definite percentage.

A very simple method of determining what amount of any given two lots of milk or cream, varying in richness, is required for combination to obtain a milk or cream of definite fat percentage is given below. This method of standardizing milk was devised by Prof. R. A. Pearson, of Cornell University.

One should construct a figure like the accompanying cut, and in the

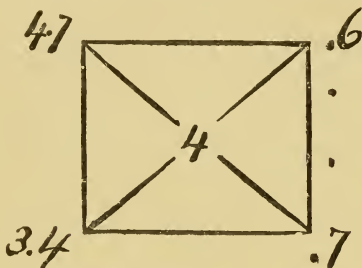

two left hand corners write the percentages of fat in the two lots of milk (or cream and milk, or two lots of cream, as the case may be).

In the centre, place the percentage of fat required. At the right hand corners write numbers which will be the differences between two numbers with which they stand in line.

Thus: If 4.7 and 3.4 are the percentages of fat in two lots of milk—and it is desired to make a mixture containing four per cent. of fat—subtract 4 from 4.7 and place the result (.7) at the lower right hand corner. Subtract 3.4 from 4 and place the result (.6) at the upper right hand corner.

The result shows that it will take six parts of 4.7 per cent. milk, and seven parts of 3.4 per cent. milk, to make a standard four per cent. milk.

Method of Keeping Accounts of a Pure Milk Dairy

(See the following three forms.)

I

MAPLEWOOD FARM

Daily Milk Report

1908
Empty cases received last train'	
Bottles short last train	
Bottles broken when received	
Bottles broken at farm	
Cases milk shipped to-dayand.....Qts.	

The foregoing report is signed by the manager at the farm. It shows the number of empty cases (holding 12 quart bottles) received from the city and the number of bottles broken and missing in them. Also the number of full cases shipped to the city.

II

Driver.....

Route No.

MILK RECEIVED	CASH ACCOUNT
Received fromRy	PAID ON ACCOUNT
Milk Cream\$.....
Quarts Gals, Pints ½ Pints

DELIVERED
Milk
Quarts.....
Cream
Pints.....	
½ Pints.....	PAID FOR TICKETS
\$.....
RETURNED
Milk
Quarts.....
Cream
Pints.....
½ Pints.....
Bottles Delivered.....	Cash Receipts..\$.....
Bottles returned.....	Total.....\$.....

This blank is filled out daily by the driver of each delivery wagon and represents, first, the amount of milk and cream received from..... railway; second, the amount of milk and cream delivered to customers; third, the amount of the same brought back to the store; fourth, the bottles delivered to and returned to customers; and fifth, the cash paid for accounts due or tickets.

III.

JOHN SMITH
14 CEDAR STREET

	1	2	3	4	5	6	7	8	9	10	11	12	13	14	15	16	17	18	19	20	21	22	23	24	25	26	27	28	29	30	31	Qts.	Pts.	½Pt.	Total	Bal.	Total	Pd.	Due			
Nov.																																										
Dec.																																										
Jan.																																										
Feb.																																										
Mar.																																										
Apr.																																										
May																																										
June																																										
July																																										
Aug.																																										
Sept.																																										
Oct.																																										

This form represents a loose card, one of which is devoted to each customer for a year. The day's sales of the drivers of the milk wagons are copied off their books each day and kept in the office of the city dairy in this form.

Practical Disinfection*

The premises occupied by animals suffering from contagious diseases, together with all articles contained therein, such as harness, blankets, stable implements, and evacuations, must be disinfected after the removal of all animals and isolation of the sick. The excreta, excrement and urine should be mixed with milk of lime (one part of freshly slacked quicklime with two parts, by volume, of water), or with pure chlorinated lime. The floors and walls must be scraped and washed. Boiling water should then be poured over every available part of the premises, and these brushed with a saturated solution of chlorinated lime. Or all available parts of infected stables should be saturated with one of the following solutions by means of a small hand force-pump or brush: 5 per cent. formalin, 2 per cent. cresol, 1 to 500 corrosive sublimate, or 5 per cent. crude carbolic acid solution.

Clothing may be treated by boiling in water, or by soaking in a solution of corrosive sublimate (1-500), or carbolic acid (1-20), for twelve hours. Harness is disinfected by washing with soap and water and then with a 2 per cent. carbolic acid or creolin, or 1-1000 corrosive solution. Valueless articles are given to the flames. Stable and metallic instruments and fixtures are to be freed from dirt, scrubbed with soap and hot water, drenched with boiling water, and then with a 5 per cent. crude carbolic acid or creolin solution.

Gaseous disinfection is now in order to kill micro-organisms in remote and inaccessible places. This is frequently out of the question, however, on account of the size or open character of the stable. Live steam is the most efficient means at our disposal for this purpose, when a suitable apparatus for its application to woodwork, haymows, etc., is obtainable. In place of this we may resort to formaldehyde, chlorine or sulphurous acid gas. In using formaldehyde all openings into the outer air should be closed as far as possible. Then 16 $\frac{2}{3}$ ounces of potassium permanganate should be added to each 20 ounces of formalin (or in this proportion) in deep tin vessels to avoid the effects of frothing. This quantity of formalin and potassium

* Winslow's Veterinary Materia Medica and Therapeutics.

permanganate is necessary to disinfect each 1,000 cubic feet of air space. The premises should be closed for six hours and then well aired.

The walls are finally painted or covered with whitewash containing five per cent. of crude carbolic acid. Healthy animals, which have not been exposed to infection, may now be allowed to return to their disinfected quarters.

The Tuberculin Test*

It is best to take the temperature of the animal from 6 A.M. every two hours until tuberculin is injected on the evening of the same day between 8 and 10 P.M. The temperature is taken with a clinical thermometer (sold by druggists), which is anointed with vaseline and held in the rectum, or bowel, for three minutes. The test is unreliable in animals whose temperature reaches 103 deg. F. (except in the young, when this may be considered a normal maximum) during the period prior to the injection. Sometimes the test is not positive in animals in an advanced stage of tuberculosis, but in these signs are often evident, as emaciation, cough, enlarged glands, etc. The test is also misleading if performed within a few days of calving—either before or after. The injection is made under the skin just behind the left shoulder blade, or on the side of the neck, with a syringe and needle previously boiled for five minutes. If a number of cows are to be tested, the needle and syringe need not be boiled before each injection is made, but the needle should be wiped off after each injection with a clean cloth saturated with alcohol. The animal should be kept in the barn at rest during the days of the test and should not be allowed large quantities of cold water to drink so as to reduce the temperature. The temperature of the animal should be taken at 6 o'clock in the morning following the injection, and from that time every two hours till 8 P.M.

A rise of two degrees or more is necessary for a positive reaction—that is, a rise of two degrees over the maximum temperature taken the previous day before the injection—in order to prove the animal has tuberculosis.

* Winslow's "Veterinary Materia Medica and Therapeutics."

Those animals in which the temperature does not rise to 103 deg. F. within fifteen, or at most twenty, hours after the injection, may be considered free from tuberculosis. When the temperature is between 103 deg. and 103.8 deg. the test is doubtful, and the animals should be re-tested after three months.

When the temperature rises gradually to 103.8 deg. F., or over, within fifteen hours after the injection, the animals may be considered positively affected with tuberculosis, providing this constitutes a rise of two degrees over the maximum temperature recorded before the injection.

Before admitting newly acquired cows to a herd they should be kept by themselves until tested twice with tuberculin without reacting. This is necessary because cows may not react in the early stage and because previous treatment with tuberculin may prevent tuberculous cows from reacting. Therefore, after a first negative test the cows are kept by themselves for three months, when a second test is made with three times the ordinary dose. Milk may be sold as certified from these animals, however, after the first test with a negative result. This is the rule: in re-tests three times the usual dose is injected, and in old and emaciated animals double the ordinary amount is used.

The average dose of tuberculin, as prepared and diluted for immediate use by the U. S. Government, is 2 c.c., or about one-half dram, representing 0.25 c.c. of pure, old tuberculin. 1 to 1.5 c.c. may be given to yearlings and two-year-olds, according to size, and bulls and large animals may receive 3 c.c. of tuberculin. Tuberculin should be kept in a cool, dark place and be rejected if it becomes cloudy. While testing cattle may be done by the laity, it had much better be done by a competent veterinary surgeon, as there are many exceptional cases which can in no way be properly interpreted by the layman.

Bacteriological Examinations

Dr. Slack writes as follows:

"We centrifugalize the milk in small glass tubes (about 2 c.c. each, the ends being closed with rubber stoppers). Our apparatus carries 20 tubes and we centrifugalize for ten minutes at a speed of 2000-3000 revolutions a minute.

"The sediment obtained on the rubber stopper is smeared evenly with a drop of sterile water over a space 4 sq. cm. By examining this sediment with a 1-12 oil immersion lens, we determine the presence of pus or streptococci and are also able to make a microscopic estimate of the number of bacteria present."

Since it is impossible to differentiate between dead leucocytes and pus, and since a certain number of leucocytes are normal (3 or 4 in a 1-12 immersion lens field) in milk, it is necessary to fix an arbitrary standard not to be exceeded by these cells. The standard, observed by the Boston Board of Health, is 50 cells to the field of a 1-12 oil immersion lens (spreading the sediment from 2 c.c. of milk over a surface of 4 sq. cm.). If this number is exceeded the milk is condemned. After the milk is centrifuged in small glass tubes (see above), the sediment is placed on spaced, glass slides, dried with gentle heat and stained with methylene blue. During the course of the microscopic examination for pus, the number of bacteria can be determined with a very fair degree of accuracy without plating the milk if the milk contains more than 100,000 bacteria in 1 c.c.

Milk is condemned by the Boston Board of Health for streptococci when 3 tests are positive: 1. When the centrifuged sediment shows streptococci, cocci or diplococci. 2. When the plate from the same sample shows colonies resembling streptococci colonies, in excess of 100,000 to 1 c.c. 3. When such colonies transferred to broth and grown for 24 hours at 37° C. show streptococci alone or in great excess of the other bacteria present.

"The examination of milk for pus was first suggested by Dr. Stokes of Baltimore, and has since been carried out in a number of public health laboratories in different parts of the United States. The researches of Stokes, Bergey, Stewart, Doane, Slack and others have

shown that cells are present in practically all samples of milk and that in some samples the cellular content is much higher than is usual. Where the number of cells is high it is customary to regard them as pus cells, but there is no general agreement as to where the line should be drawn. The question is a difficult one, because pus cells and dead leucocytes are morphologically the same and so cannot be differentiated by their appearance alone. Doane has proposed that milk shall be regarded as containing pus if there is high cellular content accompanied by threads of fibrin. Bergey proposes that pus shall be diagnosed if there are 10 cells to the field of the 1-12 immersion lens. Stewart centrifuges 1 c.c. of milk in small tubes and if he find 23 cells to the field of the 1-12 immersion lens, when the sediment of this amount of milk is spread over 1 square cm., he reports pus. Slack proposes that the sediment of .2 c.c. milk shall be spread over 4 square cm. and that pus shall be reported if 50 cells are seen to the 1-12 immersion field.

“Since there is much doubt, in many cases, as to whether high cellular content actually denotes pus,—that is, as to whether the cells found are pus cells or leucocytes,—and as to whether the cells themselves are injurious, it would appear to be desirable, for the present, to report pus only where there is high cellular content, as judged by one of the above methods, accompanied by the presence of streptococci.”—LEONARD PEARSON, in Jensen’s *“Milk Hygiene.”*

“It is evident that the whole subject is far from being on a satisfactory basis. The various methods advocated give varying results even on the same milk sample. Preheating of the milk to a high temperature and also the height of temperature reached in such preheating affect the result even when the same method is used. If a specific maximum count is to be established as a limit, the specifications must therefore include exact details of method, temperature and technique, to secure consistent and comparable results at the hands of different workers under different conditions. No such standard has yet been agreed upon. Moreover, normal cows sometimes give very exceptionally high counts and this fact adds to the difficulties in determining an absolute standard.”—W. H. HILL.

Food Requirements

Instead of basing the feeding standard on the amount and proportion of digestible nutrients (nutritive ratio), which is still the prevalent custom, a more scientific and trustworthy feeding standard is based on the amount of digestible protein in the ration and the chemical energy or fuel value of the nutrients. The body may be likened to a machine and the protein is necessary for the repair of the machine and to supply additions to the machine, as in growing animals, and in pregnant animals, and in those giving products rich in protein—as milk. Therefore, there is a standard for maintenance and another for growing animals and another for milch cows, etc.

Animals at work do not require more protein than those at rest, as the machine is running all the time and requires repairs in either case, but more fuel is required. The carbohydrates and fat represent the fuel, which is burned in the body to create heat or chemical energy, and runs the machine. It is true proteids in excess or as waste products also act as fuel, but being much more expensive than carbohydrates or fat are not desirable for fuel. Now the units of heat value for food are termed the calorie (or great calorie) and therm. The calorie is that amount of heat necessary to raise 1 kilogram (2.2 lbs) of water 1 degree centigrade. The therm is equal to the quantity of heat required to raise 1,000 kilograms (2,204.6 lbs.) of water 1° C. It is comparatively easy to estimate the heat value of food by burning it outside the body but it takes very elaborate experiments on animals to determine the heat or energy value in the body. As the result of such investigations the following tables* of the heat or energy value of food stuffs for the animal have been made. By these experiments the actual proportion of the food which undergoes combustion in the body is estimated, as part of the food escapes combustion by way of the bowels and urine, part of the energy value is used in separating the real fuel which the body can use from the useless portion, and part is used in converting fuel materials into special products, as flesh and milk.

* Bull. 346, U. S. Agricultural Dept.

The new standards for feeding (which have been used for some years in estimation of food requirements for man) demand: 1. The proper proportion and amount of dry matter. 2. Of digestible protein. 3. The proper energy value stated in calories or therms for lbs. of live weight per diem for maintenance, for growth, fattening, work, milk, etc.

The nutrient requirements are 1 lb. of digestible protein for each 8 to 10 lbs. of carbohydrates and fat, and 20 to 30 lbs. of dry matter per diem for each adult cow.

It has been found that in milk production, for each pound of milk produced, there is required (in addition to the requirements for maintenance) 0.3 therm in energy value in the food and 0.05 pound of digestible protein. Now to put this knowledge into use.

TABLE I.

Maintenance requirements of cattle and horses, per day and head.

Live weight.	Cattle.		Horses.	
	Digestible protein.	Energy value	Digestible protein.	Energy value.
Pounds.	Pounds.	Therms.	Pounds.	Therms.
150	0.15	1.70	0.30	2.00 ^a
250	.20	2.40	.40	2.80
500	.30	3.80	.60	4.40
750	.40	4.95	.80	5.80
1,000	.50	6.00	1.00	7.00
1,250	.60	7.00	1.20	8.15
1,500	.65	7.90	1.30	9.20

TABLE II.

Dry matter, digestible protein, and energy values per 100 pounds.

Feeding stuff.	Total dry matter.	Digestible Protein.	Energy value.
	Pounds.	Pounds.	Therms.
Green fodder and silage :			
Alfalfa	28.2	2.50	12.45
Clover—crimson	19.1	2.19	11.30
Clover—red	29.2	2.21	16.17
Corn fodder—green.....	20.7	.41	12.44
Corn silage.....	25.6	1.21	16.56
Hungarian grass.....	28.9	1.33	14.76
Rape	14.3	2.16	11.43
Rye.....	23.4	1.44	11.63
Timothy	38.4	1.04	19.08
Hay and dry coarse fodders :			
Alfalfa hay.....	91.6	6.93	34.41
Clover hay—red	84.7	5.41	34.74
Corn forage, field cured.....	57.8	2.13	30.53
Corn stover.....	59.5	1.80	26.53
Cowpea hay.....	89.3	8.57	42.76
Hungarian hay.....	92.3	3.00	44.03
Oat hay.....	84.0	2.59	36.97
Soy bean hay.....	88.7	7.68	38.65
Timothy hay.....	86.8	2.05	33.50
Straws :			
Oat straw.....	90.8	1.09	21.21
Rye straw.....	92.9	.63	20.87
Wheat straw.....	90.4	.37	16.56
Roots and tubers :			
Carrots	11.4	.37	7.82
Mangel-wurzels	9.1	.14	4.62
Potatoes	21.1	.45	18.05
Rutabagas.....	11.4	.88	8.00
Turnips.....	9.4	.22	5.74
Grains:			
Barley.....	89.1	8.37	80.75
Corn.....	89.1	6.79	88.84
Corn-and-cob meal.....	84.9	4.53	72.05
Oats	89.0	8.36	66.27
Pea meal.....	89.5	16.77	71.75
Rye.....	88.4	8.12	81.72
Wheat.....	89.5	8.90	82.63
By-products :			
Brewers' grains—dried.....	92.0	19.04	60.01
Brewers' grains—wet.....	24.3	3.81	14.82
Buckwheat middlings	88.2	22.34	75.92
Cotton-seed meal.....	91.8	35.15	84.20
Distillers' grains—dried—			
Principally corn.....	93.0	21.93	79.23
Principally rye.....	93.2	10.38	60.93
Gluten feed—dry.....	91.9	19.95	79.32
Gluten meal—Buffalo.....	91.8	21.56	88.80
Gluten meal—Chicago.....	90.5	33.09	78.49
Linseed meal—old process.....	90.8	27.54	78.92
Linseed meal—new process.....	90.1	29.26	74.67
Malt sprouts.....	89.8	12.36	46.33
Rye bran.....	88.2	11.35	56.65
Sugar-beet pulp—fresh.....	10.1	.63	7.77
Sugar-beet pulp—dried.....	93.6	6.80	60.10
Wheat bran.....	88.1	10.21	48.23
Wheat middlings.....	84.0	12.79	77.65

Supposing that we wish to determine a standard for feeding a herd of cows, each weighing on the average 850 lbs. and yielding on the average 25 lbs. of milk each daily:—

We first consult Table I for standards for maintenance of cattle. We find that for cattle weighing 850 lbs. the daily requirements are:—

	Digestible protein. lbs.	Energy value. Therms.
For maintenance.....	0.45	5.6
For 25 lbs. of milk.....	1.25	7.5
	<u>1.70</u>	<u>13.10</u>

For cows giving 25 lbs. of milk we find that we must add to the maintenance figures the required energy value in therms corresponding to this milk yield. It was stated above that for each pound of milk yield there will be required 0.3 therm of energy value and an allowance of 0.05 lb. of digestible protein. Therefore, multiplying each of these factors by 25, and adding the results to the required standard in digestible protein and therms for maintenance, we get the standard required for cows weighing 850 lbs. and giving daily 25 lbs. of milk, as above.

Next we desire to so arrange the various food stuffs at command that the proper proportion of dry matter and proteids are attained and, especially, that the nutrients in the aggregate furnish the amount of digestible protein and energy value required by our standard above.

We have found that there should be 20-30 lbs. of dry matter in a daily ration and at least 1 lb. of digestible protein for each 8 to 10 lbs. of the other nutrients (fat and carbohydrates).

We must first concoct a theoretical ration from the food stuffs at hand and then alter the ration to accord with the standard, or to substitute one food stuff for another on account of greater economy.

We will select the first ration on p. 72 consisting of 20 lbs. of timothy, 2 lbs. of oats, 4 lbs. of gluten meal and 4 lbs. of wheat bran.

Consulting Table II, showing dry matter, digestible protein and energy value per 100 lbs., we find that each of the food stuffs selected contain of these, as will be seen below :

	Protein, lbs.	Therms.	Dry matter.
Timothy, 20 lbs.....	.41	6.71	17.3
Oats, 2 lbs.....	.17	1.33	1.8
Bran, 4 lbs.....	.04	1.92	3.5
Gluten, 4 lbs.....	.08	3.17	3.7
	<u>1.78</u>	<u>13.13</u>	<u>26.3</u>
Total	1.78	13.13	26.3

INDEX

	Page		Page
Acidity of milk, test for	190	Bacteria, characters of.....	3, 233, 298
of pasteurized milk.....	190	classification of.....	40, 41, 237, 281
Actinomycosis affecting milk....	33	conditions of growth of,	
of udder	33	4-8, 25, 27, 239.	
Agar, plain nutrient.....	273, 283-4	darkness requisite for.....	240
Air space required by cows.....	80	essentials for life of.....	238
Albumin of milk	43	food of.....	239
Aseptic milk	301	higher	238
Ash of milk.....	43, 46	humidity required.....	240
Ayrshire cows.....	313	identification, standard meth-	
Artificial milk	269	ods	240, 282
Babcock test for milk fat.....	193	in barn.....	77, 93
Bacilli acidi lactici... 20, 21, 23, 44,	296	in butter.....	309
colon.....	21, 40, 278, 304	in buttermilk.....	309
foetidus lactis.....	27	in cheese.....	96, 311
lactis aerogenes.. 21, 202, 297,	300	in cold storage.....	4, 5
lactis viscosus	28	in cream.....	56, 58, 142, 309
tuberculosis.. 29, 30, 40, 95-97,	276	in filtered milk.....	56, 57, 106
Bacteria, action on buttermilk,		in fore milk	48, 304
cream, cheese and con-		in frozen milk.....	4
densed milk	2	in grain.....	303
action of temperature on.. 4-16,	302	in hay.....	77, 303
analysis of in milk.....	241, 307-9	in ice cream	38
apparatus required.....	278	in manure	304
controls in.....	258	in market milk.....	26
counting in	260	in milk, classification of,	
dilutions for	254	40, 41, 237, 281	
Gram's stain in.....	277	bottles	303
incubation in.....	259	utensils.....	304
media making for.. 256, 262, 72		in separated cream.....	56, 142
reaction of media for... 287		in set cream.....	58, 142
uses of media for.....	272	influence on milk and pro-	
plating in	256	ducts	19
technique of	257	lactic acid	20, 21, 44, 296
simple stain for.....	275, 295	action on man	20
standard methods for... 264		flavoring butter and	
atmosphere suitable for.....	239	cheese.....	20
capsules of.....	236	liquefying	23, 24, 77, 299
causing flavor of butter.....	58	miscellaneous.....	23, 307, 311
		flavoring butter	58

	Page		Page
Bacteria, moisture affecting	6	Black quarter affecting milk	178
multiplication of	4-6	Blue milk	27
number in clean milk	25	Bookkeeping, city milk route. 168, 344	
in air	302	Borax in milk	188
of butyric acid	27	Bottle boxes	138
of disease in milk	28-39	brushes	129
of pus in milk	250, 295, 349	caps	168
of tuberculosis in buttermilk	95	carriers	137
in milk. 29, 30, 40, 95, 97, 276		filler	125, 136
on hair	304	paper milk	140
on hands	101, 305	sterilizer	126-128
pasteurization affecting	7, 16	washer	129, 328
shape of	234	Bottled milk, cooling of	118, 124
significance of in milk	19, 24	Bottles, milk	140
of numbers of in milk	19, 24	paper milk	140
of quantity and variety in		to prevent loss of	166
milk	15, 18, 28	Bottling milk	123
of size	234	utensils for	123
of sunlight affecting	6	Botriomycosis affecting milk	33
spore bearing	4-10, 16, 77, 236	affecting udder	33
sunlight affecting	6	Broth, plain nutrient	274
stains for	275, 277, 295	Brown milk	27
standard method for analysis		Brushes for cleaning milk uten-	
of in milk	264	sils	129
for identification of	282	Burrell-Lawrence milking ma-	
standards for water supply	75	chine	338
structure of	234	Butter, action of germs on	2
temperature affecting. 4, 16, 23, 302		composition of	63, 155
suitable	239	fat, to pay creamery patrons	
Bacterial terms, glossary of	285	for	157
Bacteriologist, report of	293	flavor	58
form for	231	from fresh cream	58, 61
Bacteriology, dairy, experiments		starters	59, 61
in	293	making, losses in	155
Balanced ration, selection of	73	overrun in	154
computing	351	milk, composition of	63
specimens of	72, 73	tuberculous germs in	95, 96
Bang system	97	Bye-products of milk	65
Barn, disinfection of	346		
dust	72, 93, 303	Caps for milk bottles	168
floors	81	Care of milk by consumer	163
for milking only	82	Carriers for milk bottles	137
inspection of	178-181	Cans, cooling	123
plans of	322	milk	111, 122
ventilation of	81, 90	stoppers of	122
Barns	80, 95	Cars for milk	138
Basket, delivery	166, 167	Casease	23
Beastings	51	Casein	43
Bedding	93	computed from fat-content	199
Bitter milk	27, 28	in its relation to fat-content	199

	Page		Page
Casein, test for.....	199-202	Composition of milk affected by	
Catalase	9	nymphomania.....	51
Certified milk, circular describing	219	period of heat.....	50
cost of.....	151	period of lactation...	50
how to begin sale of.	154, 170	season.....	49
methods and standards.....	228	surroundings	50
New York requirements.....	219	treatment of cows...	50
price of	151	skim milk....	46, 57
standards and origin of....	24, 25	strippings.....	48
Cheese, action of germs on.....	2	whey	63
composition of.....	62	Concentrated milk	335
hard.....	62	Concentrates	71
making.....	62	Condensed milk, germs affecting.	2
ripening	62	Coolers, cream.....	135
soft.....	62	milk.....	113-119
Chemist's milk report.....	230	covered	119
Cholera affecting milk.....	35	Star	114
bacilli in milk	40	tubular	114
City milk supply, inspection of..	176	Cooling milk and cream.....	123, 306
Clarified milk.....	56	Cost of certified milk.....	151
Classification, bacteria in milk,		of producing milk.....	150
40, 41, 237, 281		Cow, annual cost of.....	146, 149
Migula-Chester	281	Ayrshire.....	313
Cleaning cows.....	98	care of.....	95
milk utensils.....	122, 303	census.....	146
Cloth ventilation for barns.....	88	for milk.....	313
Clothing for milkers	101, 102	dairy, characteristics of.....	313
milk room employees	133	dehorning.....	318
Cohn's solution	272, 275, 284	diseases affecting milk . .	29-44, 78
Colon bacilli.....	21, 40	grooming	98
Colostrum.....	51, 52	Guernsey.....	313
as a source of disease.....	52, 53	Holstein	313
Commercial starters, Farrington.	59-61	inspection of.....	178-180
analysis of	310	Jersey	313
Composite samples of milk.....	148	number in barn.	82
Composition of butter	63, 155	pox affecting milk.....	33
buttermilk	63	profits.....	146-149
cheese.....	63	rations.....	72-73, 351
colostrum.....	52	records.....	148
cream	57, 144	how to keep	148
altered by separator....	142	returns from.....	147
human milk	47	stall	91
milk	46-48	standard	148
affected by abortion.....	51	tuberculosis affecting man,	
excitement	50	31, 92, 96	
exposure.....	50	value of.....	321
food.	47, 66	Cream, acidity of for butter.....	191
fright	50	bottling.....	143
milking.....	48	composition of.....	57, 142, 144

	Page		Page
Cream, conditions favoring rising	54	Farrington, acidity test.....	190
cooler.....	135, 143	on starters.....	60
dipper.....	172	Fat in relation to casein.....	199
per cent. of solids in.....	57	of milk.....	45, 46
ripening of.....	58	test in milk and cream.....	193
separated, germs in.....	56, 142	Feeding affecting composition of	
separation of.....	143	milk.....	66, 68
separator.....	55, 143	balanced ration for.....	73
set.....	58	computing.....	351
starters.....	59-61	concentrates.....	71
thickeners.....	144	for milk.....	66
whipping.....	144	Haecker's rules for.....	71
Culture media for bacteria.....	255, 262-72	in relation to milking.....	76
Curdling of milk.....	20, 21, 44	of silage.....	77, 93
Curd test.....	202	Lehman's rules for.....	72
Dairy, arrangement of.....	34-37	roughage.....	71
bacteriology, exercises in....	293	salt.....	74
cows.....	313	specimen rations.....	72, 73
inspection of.....	177	standard for.....	69, 73
room.....	110	tables for.....	351-353
routine.....	131	Wolff's standard for.....	68
utensils.....	111, 145	Ferments in milk.....	8-11
washing of.....	122	affected by pasteurization....	8-11
Dehorning cows.....	318	Feser's lactoscope.....	203
Depots, milk, for infants.....	173	Filter, revolving.....	108
Diarrhea caused by milk.....	32, 38	Filtering milk.....	56, 57, 106, 118
of cows affecting milk.....	33	Fishy milk.....	74, 122
Diphtheria affecting milk.....	35	Flies in barn.....	92
bacilli in milk.....	40	spray for.....	92
carriers.....	35	Food, influence on lactation....	68
Dirt in milk.....	175-6, 305	imparting flavor to milk....	76, 77
Disease of cows affecting milk..	29-34	imparting taste to milk....	76, 77
Disinfection of barns.....	346	Foot and mouth disease affecting	
Distribution of milk.....	162	milk.....	33
Doane's determination of leuco-		Fore milk.....	48, 304
cytes.....	295	Formaldehyde in milk.....	188
Drivers' uniforms.....	170	Freezine.....	17
Drugs affecting milk.....	34	Galactase.....	9
Dust from cow.....	303	Garget affecting milk.....	31, 32
in barn.....	77, 93, 303	Gelatine in milk, test for....	192
in hay.....	77, 303	plain nutrient.....	273, 283
in milk room.....	133	germicide substance in....	5, 9, 301
Dysentery affecting milk.....	33, 35	Germs, see Bacteria.	
Ensilage affecting milk.....	75	Globulin in milk.....	43, 44
Enzymes in milk.....	8, 11	Glossary of bacterial terms....	285
affected by pasteurization....	7	Gram stain.....	277
Farms, inspection of.....	178-181	Green milk.....	27
		Grooming cows.....	98
		Guernsey cows.....	313

	Page		Page
Gutters for manure.....	94	Lactometer, New York Board of Health.....	202
Haecker's feeding rules.....	71	Lactoscope, Feser's.....	203
Hart casein test.....	200	Leucocytes, Doane's determination.....	295, 349
Hay dust.....	77	standard for.....	250, 295, 349
Heating water for dairy.....	120	Lipase.....	9
Hegelund method of stripping cows.....	341	Liquefiers.....	23-24
Holstein cows.....	313	Litmus milk.....	269, 283
Home pasteurization.....	13	Litmus solution.....	271
Human milk, composition of....	47	Löffler's blood serum.....	270-283
Iceline.....	17	Machine, milking.....	336
Ice cream, germs in.....	38	Malta fever from milk.....	35
Identification of bacteria.....	282	Manure, removal from barn.....	91
Indol, test for.....	271	a source of tuberculosis.....	30
Infant feeding, milk for.....	170-73	Market milk, bacteria in.....	26
Infant milk depots.....	173	Mastitis affecting milk.....	31, 32
Infant mortality.....	38-9	Media for milk analyses, 256, 262-72, 287	
Inspected milk.....	225	Microscopic study of milk.....	294
Inspection of milk.....	174	Migula-Chester classification, bacteria.....	281
by bacteriologist.....	231	Milk, acidity of.....	190
by chemist.....	230	action of temperature on, 4-16, 38	
of dairies...177, 183, 184, 211, 214		adulterated with borax.....	188
of dairy farms.....178-181		with boric acid.....	188
employees.....229, 231		with formaldehyde.....	188
of city dairies, 177, 183, 184, 211, 214		with salicylic acid.....	189
of city milk supply.....	176	with sodium carbonate... 188	
of creameries.....	177	albumin.....	43
of milk.....	174, 215	affected by foods.....	75-79
of wagons.....	165	by drugs.....	34
veterinary.....	178, 229	as a source of:	
Jersey cows.....	313	cholera.....	35
Keeping qualities of milk... ..	22	diarrhea.....32, 33, 38	
King system of ventilation.....	82-87	diphtheria.. ..32, 35, 37	
Laboratory, apparatus for.....	278	dysentery.....	35
Laboratory exercises in dairy bacteriology.....	293	infant mortality.....	37-39
Lactation period of cows.....	50	Malta fever.....	35
increased by feeding.....	68	milk sickness.....	34, 78
Lactic acid bacteria.....20-25		scarlet fever.....32, 35, 37	
action on man.....	20	small pox.....	35
in fermentation of milk.....	44	sore throat.....	32
flavoring butter and cheese..	20	typhoid fever.....35, 37	
killing other germs.....	20	tuberculosis... ..29, 92, 96	
Lactokinase.....	9	aseptic.....	301
Lactometer.....	146, 197	ash of.....	43, 46
		agar.....	297
		bacteria, analysis of.....	241-309
		bad odor of.....	176

	Page		Page
Milk, bad taste of.....	176	Milk fever, treatment of.....	98
bitter.....	27, 28	filtering.....	56, 57, 106, 118
bloody.....	32	fishy.....	74, 122
blue.....	27	for infant feeding.....	170-173
bookkeeping, city route..	168, 344	formation in udder.....	66
-borne epidemics.....	35-37	from silage.....	75
bottle.....	140	germicidal action of.....	5, 9, 301
caps.....	168	green.....	27
carriers.....	137	hints in delivery of.....	162
cars.....	138	house, arrangement of...	111-137
paper.....	140	plans of.....	322-335
shipping cases.....	139	human.....	47
to prevent loss of.....	166	in actinomycosis.....	33
bottling of.....	123	anthrax.....	33
utensils for.....	123	black quarter.....	178
boxes for bottles.....	139	botriomycosis.....	33, 178
brown.....	27	cow pox.....	33
bye products in manufactures	65	diarrhea.....	33
cans.....	III, 122	dysentery.....	33
cooling.....	123	foot and mouth disease..	33
stoppers.....	122	garget.....	31, 32
care of by consumer....	163	mastitis.....	31, 32
certified.....	24, 25, 170	milk fever.....	33
cost of.....	151	milk sickness.....	78
N. Y. requirements for..	219	pleuropneumonia.....	38
price of..	151	rabies.....	34
clarifying.....	56	retained afterbirth.....	33
composite samples of.....	148	septic metritis.....	33
composition of.....	46-48	suppurative conditions..	33
concentrated.....	335	tetanus.....	34
coolers.....	113-119	tuberculosis....	29, 30, 95-97
covered.....	119	umbilical infection.....	33
condensed, germs in.....	2	vaginal discharge.....	29
curdling of.....	20, 21	infection of.....	35, 185
depots for infants.....	173	inspected.....	225
dipper.....	172	inspection.....	174-232
dirt in.....	175, 176, 305	by bacteriologist.....	231
dirty, source of tyrotoxin.	38	chemist.....	230
distribution of.....	162	of barns.....	205, 209
drugs affecting.....	34	score cards for,	
during tuberculin test.....	97	205, 206, 209	
dust in.....	27, 28	cars.....	182
estimation of value.....	154	cows.....	178, 206
fat.....	45, 46	score cards for,	
test for.....	193	180, 206, 209	
feeding affecting composition		farms.....	178-181
of.....	66, 68	score cards for	
feeding for.....	66, 351	180, 205-6, 209	
ferments in.....	8-11	hotels.....	186
fever affecting.....	33	milk sales rooms.....	212

	Page		Page
Milk, inspection of pasteurized ..	216	Milk, skimmed, food value of,	
pastures	206	64, 159, 160	
restaurants	186	test for	204
ventilation	205	slimy	27, 28, 32, 176
wagons	182, 211	soapy	27
veterinary	178, 229	solids	43, 46, 197-204
score card for	230	estimation of	199
water supply	205	souring of	20, 21, 44
keeping qualities of	22	standard for cow	148
leucocytes in	295	standardizing	343
standard for ..	250, 296, 349	standards	25, 249
licenses, see Permits.		starters	59-61
litmus	269	analysis of	310
medium	269	sterilizers	126, 128
microscopic study of	294	stirrer	132
mineral matter in	43, 46	strainers	118
mixing	111, 119	stringy	27, 28, 32, 176
modified	170	strippings	48
pails	104-107	sugar	43
pasteurized	7-16, 307	sweet	17
tests for	189, 216	curdling	33, 44
pasteurizers	15	tickets	167
permits	204	time of delivery	162
dairy	207	turnip flavor of	77
farm	207	utensils	111-145
milk importer	207	washing	122
notice revoking	179	wagons	165
preservatives	17	inspection of	165
tests for	188, 189	watered, test for	204
production, cost of	150	woman's	47
properties, chemical	42	yellow	27
physical	42	yield, conditions affecting ..	48-51
vital	42	temperature affecting ..	4-6
proteids	43	Milkers, cleanliness of	101
pus in	249, 296	dress of	101-102
standards for ..	250, 296, 349	Milking	102
reaction of	42	affecting composition of milk	101
records	148	barns	82
red	27	in relation to feeding ..	76
returns	160	machine	336
ropy	27-8, 32, 176	period	50
room	111, 137	Mineral matter in milk	43, 46
utensils	111	Miscellaneous bacteria in milk ..	23
routine	131	Mixing milk	111, 119
samples	174, 175	Modified milk for infants	170
collecting	251	Nitrate broth	270
scarlet fever from	33	Nitrites, test for	271
secretion, physiology of	71	Oidium lactis	297
sickness	34, 78		
siphons	172		

	Page		Page
Overrun	154	Scarlet fever organisms	40
how to estimate	156	Score cards for barns	205, 209
Pails, milk	104-107	barnyards	206
Paper milk bottle	140	cows	206, 209
Paracasein	44	city milk plants	211, 214
Pasteurization	7-16	dairies	209, 214
affecting ferments	8-11	handling of milk	209
city regulations for	216	milkers	209
cost of	14	wagons	212
disease germs affected by	7-15	Separation of cream	143
germs in	307	removing germs	56, 142
home	13	dirt	56
spores affected by	7-16	Separator cream	56
Pasteurized milk, tests for,		slime	59
189, 216, 307		Separators, management of	321
Pasteurizers	15	Serum	275
Permits, dairy	207	Septic metritis affecting milk	33
farm	207	Shipping cases	138
milk importer	207	Siphon, milk	172
Plans of barns	322-333	Silicate jelly	272, 275, 284
of city dairy	335	Skim milk, composition of	46, 57
of dairies	324-335	food value of	64, 159, 160
Pleuropneumonia affecting milk ..	33	test for	204
Potato medium	270	value of	64, 159, 160
Preservatives	33	Slimy milk	27, 28, 32
tests for	188-189	Smallpox infecting milk	35
Price of certified milk	151	Soapy milk	27
Proteids in milk	43	Sodium carbonate in milk	188
Pseudomonas coli	40	Solids of milk	43, 46, 48, 197-204
Putrefactive germs	23, 24	test for	199
Quevenne's lactometer	197	Sources of bacteria in milk classi-	
Rabies affecting milk	34	fied	41
Reaction of media, adjustment ..	287	Souring of milk	20, 21, 44
Records of cows	314	Spores in milk	4, 7, 8, 10, 16, 77
of milk	148, 320	Stables, disinfection of	346
Red milk	27, 28	Stalls	90
Retained afterbirth affecting milk	33	Stanchions	90, 331
Roughage	71	Standardizing milk	343
Rutherford ventilating system ..	89	Star cooler	114
Salicylic acid in milk	189	Starch jelly	275
Salt for cows	74	Starters	59, 310
Sampling milk	174, 251	Startoline	60
Samples, milk, form for collectors		Steam heating tee	131
of	215	Sterilizers	126-128
Scarlet fever from milk	32	Storch's test	189
infecting milk	35-37	Strainer cloths	118
		Straining milk	56, 57, 106, 118
		Streptococci	18, 31, 32, 250
		standards for in milk	250, 349
		Streptococcus lacticus	21

	Page		Page
Stringy milk	27, 28, 32	Tyrotrotoxin in milk	38
Stripping cows, Hegelund method	341	Udder, anatomy of	48
Strippings of milk	48	actinomycosis of	33
Sugar of milk	43	botriomycosis of	33
Suppuration affecting milk	20	physiology of	66
Sweet curdling of milk	33, 44	tuberculosis of	29, 32
Tail holder	99	Umbilical infections infecting milk	33
Temperatures affecting milk	4-16, 302	Uschinsky's solution	272, 275, 284
Test for acidity of milk	190-192	Utensils	111, 145
for gelatine	192	cleaning	122
indol	271	in milk room	111
nitrites	271	Vaginal discharge in milk	30, 33
pasteurized milk	189	Ventilation of barns	82-90
preservatives	188	cloth method	88
pus	295, 349	King system of	82-87
solids in milk	197, 203	Rutherford system	89
streptococci	250, 349	Veterinary inspection of cows,	
tuberculosis	95, 347	100, 178, 229	
viscogen	192	reports	230
watered milk	204	Viscogen in milk	144, 192
Tetanus affecting milk	34	Wagons, milk	165
Tickets, milk	167	Washing dairy utensils	122, 192, 303-4
Tie-ups	90, 331	machine	328
Tonsilitis from milk	32	sink	122
Transportation of cans	123	Water, germ standard for	75
Trembles	34, 78	for dairy use	37, 74-75
Tubercle bacilli, stain for	276	heating	120
Tuberculin test	95, 347	supply	74-75
Tuberculosis affecting cow	29, 30	stagnant, in pastures	74
affecting man through milk,		Watered milk, test for	204
31, 92, 96		Watering cows	74
udder	29, 32	Wells	75
bacilli in butter	95-96	Whey, composition of	63
in milk	29, 30, 40, 95-97	Whipping cream	144
stain for	276	Yellow milk	27
Tuberculous cows, dangers of,		Ziehl-Nielsen stain	276
31, 92, 96			
Tubular coolers	114		
Typhoid fever affecting milk	35, 37, 40		
carriers	35		

CATALOGUE OF William R. Jenkins Co.'s

Works Concerning

HORSES, CATTLE, SHEEP, SWINE, Etc.

1909

(*) *Designates New Books.*
(†) *Designates Recent Publications.*

- ANDERSON.** "Vice in the Horse" and other papers on Horses and Riding. By E. L. Anderson. Size, 6 x 9, cloth, illustrated.....1 75
- ARMSTEAD.** "The Artistic Anatomy of the Horse." A brief description of the various Anatomical Structures which may be distinguished during Life through the Skin. By Hugh W. Armstead, M.D., F.R.C.S. With illustrations from drawings by the author. Cloth oblong, 10 x 12½.....3 75
- BACH.** "How to Judge a Horse." A concise treatise as to its Qualities and Soundness; Including Bits and Biting, Saddles and Saddling, Stable Drainage, Driving One Horse, a Pair, Four-in-hand, or Tandem, etc. By Capt. F.W. Bach. Size, 5 x 7½, clo., fully illus. 1 00
- BANHAM.** "Tables of Veterinary Posology and Therapeutics," with weights, measures, etc. By Geo. A. Banham, F. R. C. V. S. New edition. Cloth, size 4 x 5 1-2, 192 pages.....1 00
- BAUCHER.** "Method of Horsemanship." Including the Breaking and Training of Horses. By F. Baucher.....1 00
- BELL.** (*) "The Veterinarian's Call Book (Perpetual)." By Roscoe R. Bell, D.V.S., editor of the *American Veterinary Review*. Completely revised.
A visiting list, that can be commenced at any time and used until full, containing much useful information for the student and the busy practitioner. Among contents are items concerning: Prescription writing; Veterinary Drugs; Poisons; Solubility of Drugs; Composition of Milk, Bile, Blood, Gastric Juice, Urine, Saliva; Respiration; Dentition; Temperature, etc., etc. Bound in flexible leather, with flap and pocket.....1 25

BITTING. "Cadiot's Exercises in Equine Surgery."
See "Cadiot."

BRADLEY. "Outlines of Veterinary Anatomy."

By O. Charnock Bradley, Member of the Royal College of Veterinary Surgeons; Professor of Anatomy in the New Veterinary College, Edinburgh.

The author presents the most important facts of veterinary anatomy in as condensed a form as possible, consistent with lucidity. 12mo.

Complete in three parts.

PART I.: <i>The Limbs</i> (cloth).....	1 25
PART II.: <i>The Trunk</i> (paper)	1 25
PART III.: <i>The Head and Neck</i> (paper).....	1 25
THE SET COMPLETE	3 25

CADIOT. "Exercises in Equine Surgery." By P. J. Cadiot. Translated by Prof. A. W. Bitting, D.V.M. Edited by Prof. A. Liautard, M.D.V.M. Size, 6 x 9½. cloth, illustrated..... 2 50

— "Roaring in Horses." Its Pathology and Treatment. This work represents the latest development in operative methods for the alleviation of roaring. Each step is most clearly defined by excellent full-page illustrations. By P. J. Cadiot, Professor at the Veterinary School, Alfort. Translated by Thos. J. Watt Dollar, M.R.C.V.S., etc. Cloth, size 5 1-4 x 7 1-8, 77 pages, illustrated..... 75

— "Studies in Clinical Veterinary Medicine and Surgery." By P. J. Cadiot. Translated, edited, and supplemented with 49 new articles and 34 illustrations by Jno. A. W. Dollar, M.R.C.V.S. Cloth, size 7 x 9 3-4, 619 pages, 94 black and white illustrations..... 5 25

—(*) "A Treatise on Surgical Therapeutics of the Domestic Animals." By P. J. Cadiot and J. Almy. Translated by Prof. A. Liautard, M.D., V.M.

General Surgery.—Means of restraint of animals, general anæsthesia, local anæsthesia, surgical antiseptics and asepsis, hematosis, cauterization, firing, Diseases Common to all Tissues.—Inflammation, abscess, gangrene, ulcers, fistula, foreign bodies, traumatic lesions, complications of traumatic lesions, granulations, cicatrices, mycosis, virulent diseases, tumors.

Diseases Special to all Tissues and Affections of the Extremities.—Diseases of skin and cellular tissue, of serous bursae, of muscles, of tendons, of tendinous synovial sacs, of aponeurosis, of arteries, of veins, of lymphatics, of nerves, of bones, of articulations.

Cloth, size 6 x 9, 580 pages, 118 illustrations..... 4 50

CAMPBELL and LECROIX. (*) "Essentials of Parasitology," with a brief discourse on ZOOLOGY. Size 5 3-4 x 8 1-2, 96 pages, with three Charts..... 1 00

- CHAPMAN.** "Manual of the Pathological Treatment of Lameness in the Horse," treated solely by mechanical means. By George T. Chapman. Cloth, size 6 x 9, 124 pages with portrait..... 2 00
- CLARKE.** "Chart of the Feet and Teeth of Fossil Horses." By W. H. Clarke. Card, size 9 1-2 x 12.. 25
- "Horses' Teeth." Fourth edition, re-revised, with second appendix. Cloth, size 5 1-4 x 7 1-2, 322 pp., illus.. 2 50
- CLEVELAND.** "Pronouncing Medical Lexicon." Pocket edition. By C H. Cleveland, M.D. Cloth, size 3 1-4 x 4 1-2, 302 pages..... 75
- CLEMENT.** "Veterinary Post Mortem Examinations." By A. W. Clement, V.S. The absence in the English language of any guide in making autopsies upon the lower animals, induced Dr. Clement to write this book, trusting that it would prove of practical value to the profession. Cloth, size 5 x 7 1-2, 64 pages, illustrated..... 75
- COURTENAY.** (†) "Manual of the Practice of Veterinary Medicine." By Edward Courtenay, V. S. Revised by Frederick T. G. Hobday, F.R.C.V.S. Second edition. Cloth, size 5 1-4 x 7 1-2, 573 pages 2 75
- COX.** "Horses: In Accident and Disease." The sketches introduced embrace various attitudes which have been observed, such as in choking; the disorders and accidents occurring to the stomach and intestines; affection of the brain; and some special forms of lameness, etc. By J. Roalfe Cox, F.R.C.V.S. Cloth, size 6 x 9, 28 full page illustrations..... 1 50
- DALRYMPLE.** (*) "Veterinary Obstetrics." A compendium for the use of advanced students and Practitioners. By W. H. Dalrymple, M. R. C. V. S., principal of the Department of Veterinary Science in the Louisiana State University and A. & M. College; Veterinarian to the Louisiana State Bureau of Agriculture, and Agricultural Experiment Stations. Second edition revised. Cloth, size 6x9 1-4, 162 pages, 51 illustrations..... 2 50
- DALZIEL.** "Breaking and Training Dogs." Part I, by Pathfinder. Part II, by Hugh Dalziel. Cloth, illustrated..... 2 50
- "The Collie." By Hugh Dalziel. Paper, illustrated.... 50
- "The Diseases of Dogs." Causes, symptoms and treatment. By Hugh Dalziel. Illustrated. Paper, 50c. Cloth, 1 (0
- "Diseases of Horses." Paper 50
- "The Fox Terrier." By Hugh Dalziel. Paper, 50; clo. 1 00
- "The Greyhound." Cloth, illus..... 1 00
- "The St. Bernard." Cloth, illustrated..... 1 00

DANA. "Tables in Comparative Physiology." By Prof. C. L. Dana, M.D. Chart, 17 x 17..... 25

DANCE. "Veterinary Tablet." By A. A. Dance. Chart, 17 x 24, mounted on linen, folded in a cloth case for the pocket, size 3 3-4 x 6 1-2. Shows at a glance the synopsis of the diseases of horses, cattle and dogs; with their cause, symptoms and cure..... 75

DE BRUIN. (*) "Bovine Obstetrics." By M. G. De Bruin Instructor of Obstetrics at the State Veterinary School in Utrecht. Translated by W. E. A. Wyman, formerly Professor of Veterinary Science at Clemson A. & M. College, and Veterinarian to the South Carolina Experiment Station. Cloth, size 6 x 9, 382 pages, 77 illustrations..... 5 00

Synopsis of the Essential Features of the Work

1. Authorized translation.
2. The only obstetrical work which is up to date.
3. Written by Europe's leading authority on the subject.
4. Written by a man who has practiced the art a lifetime.
5. Written by a man who, on account of his eminence as bovine practitioner and teacher of obstetrics, was selected by Prof. Dr. Fröhner and Prof. Dr. Bayer (Berlin and Vienna), to discuss bovine obstetrics both practically and scientifically.
6. The only work containing a thorough differential diagnosis of ante and post partum diseases.
7. The only work doing justice to modern obstetrical surgery and therapeutics.
8. Written by a man whose practical suggestions revolutionized the teaching of veterinary obstetrics even in the great schools of Europe.
9. The only work dealing fully with the now no longer obscure contagious and infectious diseases of calves.
10. Absolutely original and no compilation.
11. The only work dealing fully with the difficult problem of teaching obstetrics in the colleges.
12. The only work where the practical part is not overshadowed by theory.

A veterinarian, particularly if his location brings him in contact with obstetrical practice, who makes any pretence toward being scientific and in possession of modern knowledge upon this subject, will not be without this excellent work, as it is really a very valuable treatise.—Prof. Roscoe R. Bell, in the *American Veterinary Review*.

In translating into English Professor De Bruin's excellent textbook on Bovine Obstetrics, Dr. Wyman has laid British and American veterinary surgeons and students under a debt of gratitude. The work represents the happy medium between the booklets which are adapted for cramming purposes by the student, and the ponderous tomes which, although useful to the teacher, are not exactly suited to the requirements of the everyday practitioner. . . . We can strongly recommend the work to veterinary students and practitioners.—*The Journal of Comparative Pathology and Therapeutics*.

DOLLAR. (*) "Diseases of Cattle, Sheep, Goats and Swine." By G. Moussu and Jno. A. W. Dollar, M.R.C.V.S. Size 6 x 9 1-2, 785 pages, 329 illustrations in the text and 4 full page plates..... 8 75

— (†) "A Hand-book of Horse-Shoeing," with introductory chapters on the anatomy and physiology of the horse's foot. By Jno. A. W. Dollar, M.R.C.V.S., with the collaboration of Albert Wheatley, F.R.C.V.S. Cloth, size 6 x 8 1-2, 433 pages, 406 illustrations . . 4 75

DOLLAR (continued)

- (†) **“Operative Technique.”** Volume 1 of **“The Practice of Veterinary Surgery.”** Cloth, size 6 3-4 x 10, 264 pages, 272 illustrations..... 3 75
- **“General Surgery.”** Volume 2 of **“The Practice of Veterinary Surgery.”** In preparation.
- (†) **“Regional Veterinary Surgery.”** Volume 3 of **“The Practice of Veterinary Surgery.”** By Drs. Jno. A. W. Dollar and H. Möller. Cloth, size 6 1-2 x 10 853 and xvi pages, 315 illustrations..... 6 25
- **“Cadiot’s Clinical Veterinary Medicine and Surgery.”**
See “Cadiot.”
- **“Cadiot’s Roaring in Horses.”** *See “Cadiot.”*

DUN. **“Veterinary Medicines, their Actions and Uses.”**
By Finlay Dun, V.S., late lecturer on Materia Medica and Dietetics at the Edinburgh Veterinary College, and Examiner in Chemistry to the Royal College of Veterinary Surgeons. Edited by James Macqueen, F.R.C.V.S. Tenth revised English edition. Cloth, size 6 x 9..... 3 75

FLEMING. **“The Contagious Diseases of Animals.”** Their influence on the wealth and health of nations and how they are to be combated. Paper, size 5 x 7 1-2, 30 pages 25

— **“Human and Animal Variolæ.”** A Study in Comparative Pathology. Paper, size 5 1-2 x 8 1-2, 61 pages.... 25

— **“Parasites and Parasitic Diseases of the Domesticated Animals.”** By L. G. Neumann. Translated by Dr. Fleming. *See “Neumann.”*

— **“Operative Veterinary Surgery.”** Vol. I, by Dr. Geo. Fleming, M.R.C.V.S. This valuable work, one of the most practical treatises yet issued on the subject in the English language, is devoted to the common operations of Veterinary Surgery; and the concise descriptions and directions of the text are illustrated with numerous wood engravings. Cloth, size 6 x 9 1-4, 285 and xviii pages, 343 illustrations..... 2 75

(*) Vol. II, edited and passed through the press by W. Owen Williams, F.R.C.V.S. Cloth, size 6 x 9 1-4, 430 and xxxvii pages, 344 illustrations..... 3 25

— **“Roaring in Horses.”** By Dr. George Fleming, F.R.C.V.S. Its history, nature, causes, prevention and treatment. Cloth, size 5 1-2 x 8 3-4, 160 pages, 21 engravings, 1 colored plate..... 1 50

— **“Veterinary Obstetrics.”** Including the Accidents and Diseases incident to Pregnancy, Parturition, and the Early Age in Domesticated Animals. By Geo. Fleming, F.R.C.V.S. Cloth, size 6 x 8 3-4, 758 pages, illus. 6 25

GOTTHEIL. (*) "A Manual of General Histology."

By Wm. S. Gottheil, M.D., Professor of Pathology in the American Veterinary College, New York; etc., etc.

Histology is the basis of the physician's art, as Anatomy is the foundation of the surgeon's science. Only by knowing the processes of life can we understand the changes of disease and the action of remedies; as the architect must know his building materials, so must the practitioner of medicine know the intimate structure of the body. To present this knowledge in an accessible and simple form has been the author's task. Second edition revised. Cloth, size 5 1-2 x 8, 152 pages, 68 illustrations... 1 00

GRESSWELL. "Diseases and Disorders of the Horse."

A Treatise on Equine Medicine and Surgery, being a contribution to the science of comparative pathology.

By Albert, Jas. B. and Geo. Gresswell. Cloth, size 5 3-4 x 8 3-4, 227 pages, illustrated. 1 75

— "The Bovine Prescriber." For the use of Veterinarians and Veterinary Students. Second edition, revised and enlarged, by James B. and Albert Gresswell, M.R.C.V.S. Cloth, size, 5 x 7 1-2, 102 pages..... 75

— "The Equine Hospital Prescriber." For the use of Veterinary Practitioners and Students. Third edition revised and enlarged, by Drs. James B. and Albert Gresswell, M.R.C.V.S. Cloth, size 5 x 7 1-2, 165 pages..... 75

— Manual of "The Theory and Practice of Equine Medicine." By James B. Gresswell, F.R.C.V.S., and Albert Gresswell, M.R.C.V.S. Second edition revised. Cloth, size 5 1-4 x 7 1-2, 539 pages..... 2 75

— (†) "Veterinary Pharmacopœia and Manual of Comparative Therapy." By George and Charles Gresswell, with descriptions and physiological actions of medicines, by Albert Gresswell. Second edition revised and enlarged. Cloth, 6 x 8 3-4, 457 pages..... 3 50

HASSLOCH. "A Compend of Veterinary Materia Medica and Therapeutics."

By A. C. Hassloch, V.S., Lecturer on Materia Medica and Therapeutics, and Professor of Veterinary Dentistry at the New York College of Veterinary Surgeons and School of Comparative Medicine, N. Y. Cloth, size 5 1-4 x 7 1-2, 225 pages..... 1 50

HEATLEY. "The Stock Owner's Guide."

A handy Medical Treatise for every man who owns an ox or cow.

By George S. Heatley, M.R.C.V.S. Cloth, size 5 1-4 x 8, 172 pages..... 1 25

HILL. (†) "The Diseases of the Cat." By J. Woodroffe Hill, F.R.C.V.S. Cloth, size 5 1-4 x 7 1-2, 123 pages, illustrated..... 1 25

Written from the experience of many years' practice and close pathological research into the maladies to which our domesticated feline friends are liable—a subject which it must be admitted has not found the prominence in veterinary literature to which it is undoubtedly entitled.

— "The Management and Diseases of the Dog." By J. Woodroffe Hill, F.R.C.V.S. Cloth, size 5 x 7 1-2, extra fully illustrated.

HINEBAUCH. "Veterinary Dental Surgery." By T. D. Hinebauch, M.S.V.S. For the use of Students, Practitioners and Stockmen. Cloth, size 5 1-4 x 8, 256 pages, illustrated..... 2 00

HOARE. (*) "A Manual of Veterinary Therapeutics and Pharmacology." By E. Wallis Hoare, F.R.C.V.S. Cloth, size 5 1-4 x 7 1-4, xxvi plus 780 pages..... 4 75

HOBDAY. (†) "The Castration of Cryptorchid Horses and the Ovariectomy of Troublesome Mares." By Frederick T. G. Hobday, F.R.C.V.S. Cloth, size 5 3-4 x 8 3-4, 106 pages, 34 illustrations..... 1 75

HUNTING. (†) The Art of Horse-shoeing. A manual for Horseshoers. By William Hunting, F.R.C.V.S., ex-President of the Royal College of Veterinary Surgeons. One of the most up-to-date, concise books of its kind in the English language. Cloth, size 6 x 9 1-4. 126 pages, 96 illustrations..... 1 00

JENKINS. (*) "Anatomical and Physiological Model of the Cow." Half life size. Composed of superposed plates, colored to nature, showing internal organs, muscles, skeleton, etc., mounted on strong boards, with explanatory text. Size of Model opened, 10 ft. x 3 ft., closed 3 ft. x 1½ ft..... 12 00

— "Anatomical and Physiological Model of the Horse." Half life size. Size of Model 38 x 41 in..... 12 00

Models also in smaller sizes of the Horse, Cow, Dog, Sheep and Pig, at \$3.50 each.

JONES. (*) "The Surgical Anatomy of the Horse." By Jno. T. Share Jones, M.R.C.V.S. Parts I, II and III ready. To be completed in four parts. Each part—paper, \$4.25; cloth, \$5.00.

KOBERT. "Practical Toxicology for Physicians and Students" By Professor Dr. Rudolph Kobert, Medical Director of Dr. Brehmer's Sanitarium for Pulmonary Diseases at Goerbersdorf in Silesia (Prussia), late Director of the Pharmacological Institute, Dorpat, Russia. Translated and edited by L. H. Friedburg, Ph.D. Authorized Edition. Practical knowledge by means of tables which occupy little space, but show at a glance similarities and differences between poisons of the same group. Also rules for the Spelling and Pronunciation of Chemical Terms, as adopted by the American Association for the Advancement of Science. Cloth, 6 1-2 x 10, 201 pp..2 50

KOCH. "Etiology of Tuberculosis." By Dr. R. Koch. Translated by T. Saure. Cloth, size 6 x 9 1-4, 97 pages.....1 00

LAW. "Farmers' Veterinary Adviser." A Guide to the Prevention and Treatment of Disease in Domestic Animals. By Prof. James Law. Cloth, size 5 1-4 x 7 1-2, illustrated.....3 00

LIAUTARD. (†)"Animal Castration." A concise and practical Treatise on the Castration of the Domestic Animals. The only work on the subject in the English language. By Alexander Liautard, M.D., V.S. Having a fine portrait of the author. Tenth edition revised and enlarged. Cloth, size 5 1-4 x 7 1-2, 165 pages, 45 illustrations.....2 00

..... The most complete and comprehensive work on the subject in English veterinary literature.—*American Agriculturist.*

— "Cadiot's Exercises in Equine Surgery." Translated by Prof. Bitting and edited by Dr. Liautard.
See "Cadiot."

— "A Treatise on Surgical Therapeutics of the Domestic Animals." By Prof. Dr. P. J. Cadiot and J. Almy. Translated by Prof. Liautard. *See "Cadiot."*

— "How to Tell the Age of the Domestic Animal." By Dr. A. Liautard, M.D., V.S. Standard work upon this subject, concise, helpful and containing many illustrations. Cloth, size 5 x 7 1-2, 35 pages, 42 illustrations..... 50

— "Lameness of Horses and Diseases of the Locomotory Apparatus." By A. Liautard, M.D., V.S. This work is the result of Dr. Liautard's many years of experience. Cloth, size 5 1-4 x 7 1-2, 314 pages.....2 50

LIAUTARD (continued).

- (*) **“Manual of Operative Veterinary Surgery”** By A. Liautard, M.D., V.M. Engaged for years in the work of teaching this special department of veterinary medicine, and having abundant opportunities of realizing the difficulties which the student who earnestly strives to perfect himself in his calling is obliged to encounter, the author formed the determination to facilitate his acquisition of knowledge, and began the accumulation of material by the compilation of data and arrangement of memorandum, with the recorded notes of his own experience, the fruit of a long and extended practice and a careful study of the various authorities who have illustrated and organized veterinary literature. Revised edition, with complete index. Cloth, size 6 1-4 x 9, xxx and 803 pages, 563 illustrations..... 5 00
- **“Pellerin’s Median Neurotomy in the Treatment of Chronic Tendinitis and Periostosis of the Fetlock.”** Translated by Dr. A. Liautard. See *“Pellerin.”*
- **“Vade Mecum of Equine Anatomy.”** By A. Liautard, M.D.V.S. For the use of advanced students and veterinary surgeons. Third edition. Cloth, size 5 x 7 1-2, 30 pages and 10 full page illustrations of the arteries. 2 00
- Zundel’s **“The Horse’s Foot and Its Diseases.”**
See “Zundel.”
- LONG.** **“Book of the Pig.”** Its selection, Breeding, Feeding and Management. Cloth..... 4.00
- LOWE.** (†) **“Breeding Racehorses by the Figure System.”** Compiled by the late C. Bruce Lowe. Edited by William Allison, “The Special Commissioner,” *London Sportsman*, Hon. Secretary Sporting League, and Manager of the International Horse Agency and Exchange. With numerous fine illustrations of celebrated horses. Cloth, size 8 x 10, 262 pages..... 7 50
- LUDLOW.** **“Science in the Stable”;** or How a Horse can be Kept in Perfect Health and be Used Without Shoes, in Harness or under the Saddle. With the Reason Why. Second Edition. By Jacob R. Ludlow, M.D. Late Staff Surgeon, U. S. Army. Paper, size 4 1-2 x 5 3-4, 166 pages..... 50
- LUPTON.** **“Horses: Sound and Unsound,”** with Law relating to Sales and Warranty. By J. Irvine Lupton. F.R.C.V.S. Cloth, size 5 3-4 x 7 1-2, 217 pages, 23 illustrations..... 1 25

- M'FADYEAN.** (†) "Anatomy of the Horse." Second edition completely revised. A Dissection Guide. By John M'Fadyean, M.B., B.Sc., F.R.S.E. Cloth, size 6 x 8 3/4, 388 pages, illustrated.....6 50
This book is intended for Veterinary students, and offers to them in its 48 full-page colored plates, 54 illustrations and excellent text, a valuable and practical aid in the study of Veterinary Anatomy, especially in the dissecting room.
- "Comparative Anatomy of the Domesticated Animals." By J. M'Fadyean. Profusely illustrated, and to be issued in two parts.
Part I—Osteology. ready. Size 5 1/2 x 8 1/2, 166 pages, 132 illustrations. Paper, 2 50; cloth.....2 75
(Part II in preparation.)
- MAGNER.** "Standard Horse and Stock Book." By D. Magner. Comprising over 1,000 pages, illustrated with 1756 engravings. Leather binding.6 00
- MILLS.** "How to Keep a Dog in the City." By Wesley Mills, M.D., D.V.S. It tells how to choose, manage, house, feed, educate the pup, how to keep him clean and teach him cleanliness. Paper, size 5 x 7 1/2, 40 pages..... 25
- MOHLER.** "Handbook of Meat Inspection." By Robert Ostertag, M.D. Translated by Earley Vernon Wilcox, A.M., Ph.D. With an introduction by John R. Mohler, V.M.D., A.M. See "Ostertag."
- MÖLLER — DOLLAR.** (†) "Regional Veterinary Surgery." See "Dollar."
- MOSSELMAN-LIÉNAUX.** "Manual of Veterinary Microbiology." By Professors Mosselman and Liénaux, Nat. Veterinary College, Cureghem, Belgium. Translated and edited by R. R. Dinwiddie, Professor of Veterinary Science, College of Agriculture, Arkansas State University. Cloth, size 5 1/2 x 8, 342 pages, illustrated.....2 00
- MOUSSU.** (*) "Diseases of Cattle, Sheep, Goats and Swine." See "Dollar."
- NEUMANN.** (*) "A Treatise on Parasites and Parasitic Diseases of the Domesticated Animals." A work to which the students of human or veterinary medicine, the sanitarian, agriculturist or breeder or rearer of animals, may refer for full information regarding the external and internal Parasites—vegetable and animal—which attack various species of Domestic Animals. A Treatise by L. G. Neumann, Professor at the National Veterinary School of Toulouse. Translated and edited by Geo. Fleming, C.B., LL.D., F.R.C.V.S. Second edition, revised and edited by James Macqueen, F.R.C.V.S., Professor at the Royal Veterinary College, London. Cloth, size 6 3/4 x 10, xvi + 698 pages, 365 illustrations 6 75

NOCARD. "The Animal Tuberculoses, and their Relation to Human Tuberculosis." By Ed. Nocard, Prof. of the Alfort Veterinary College. Translated by H. Scurfield, M.D. Ed., Ph. Camb. Cloth, 5 x 7 1-2, 143 pages..1 00

Perhaps the chief interest to doctors of human medicine in Professor Nocard's book lies in the demonstration of the small part played by heredity, and the great part played by contagion in the propagation of bovine tuberculosis.

NUNN. (*) "Veterinary Toxicology." By Joshua A. Nunn, F.R.C.V.S. The study of toxicology is intimately blended with other biological sciences, particularly physiology and chemistry, both of which it on many occasions overlaps. A carefully arranged and complete index is given in the front of the volume. Cloth, size 6 x 8 3-4, vii + 191 pages.....1 75

OSTERTAG. (*) "Handbook of Meat Inspection." By Robert Ostertag, M.D. Authorized Translation by Earley Vernon Wilcox, A.M., Ph.D. With an introduction by John R. Mohler, V.M.D., A.M. The work is exhaustive and authoritative and has at once become the standard authority upon the subject. Second edition, revised. Cloth, size 6 3-4 x 9 3-4, 920 pages, 260 illustrations and 1 colored plate.7 50

PALLIN. (*) "A Treatise on Epizootic Lymphangitis." By Capt. W. A. Pallin, F.R.C.V.S. In this work the author has endeavored to combine his own experience with that of other writers and so attempts to give a clear and complete account of a subject about which there is little at present in English veterinary literature. Cloth, size 5 3-4 x 8 1-2, 90 pages, with 17 fine full page illustrations.....1 25

PEGLER. "Goat Keeping for Amateurs." Paper, 5x7 $\frac{1}{2}$, 77 pages, illustrated..... 50

PELLERIN. "Median Neurotomy in the Treatment of Chronic Tendinitis and Periostosis of the Fetlock." By C. Pellerin, late repetitor of Clinic and Surgery to the Alfort Veterinary School. Translated, with Additional Facts Relating to It, by Prof. A. Liautard, M.D., V.M. Having rendered good results when performed by himself, the author believes the operation, which consists in dividing the cubito-plantar nerve and in excising a portion of the peripheral end, the means of improving the conditions, and consequently the values of many apparently doomed animals. Agriculture in particular will be benefited.

The work is divided into two parts. The first covers the study of Median Neurotomy itself; the second, the exact relations of the facts as observed by the author. Boards, 6 x 9 1-2, 61 pages, illustrated..1 00

PETERS. "A Tuberculous Herd—Test with Tuberculin." By Austin Peters, M. R. C. V. S., Chief Inspector of Cattle for the New York State Board of Health during the winter of 1892-93. Pamphlet.... 25

REYNOLDS. "An Essay on the Breeding and Management of Draught Horses." By R. S. Reynolds, M. R. C. V. S. Cloth, size 5 1-2 x 8 3-4, 104 pages... 1 40

ROBERGE. "The Foot of the Horse," or Lameness and all Diseases of the Feet traced to an Unbalanced Foot Bone, prevented or cured by balancing the foot. By David Roberge. Cloth, size 6 x 9 1-4, 308 pages, illustrated..... 5 00

SESSIONS. (*) "Cattle Tuberculosis," a Practical Guide to the Agriculturist and Inspector. By Harold Sessions, F. R. C. V. S., etc. Second edition. Size 5 x 7 1-4, vi + 120 pages..... 1 00

The subject can be understood by those who have to deal particularly with it, yet who, perhaps, have not had the necessary training to appreciate technical phraseology.

SEWELL. "The Examination of Horses as to Soundness and Selection as to Purchase." By Edward Sewell, M. R. C. V. S. Paper, size 5 1-2 x 8 1-2, 86 pages, illustrated with 8 plates in color..... 1 50

.... It is a great advantage to the business man to know something of the elements of law, and nobody ought either to buy or own a horse who does not know something about the animal. That something this book gives, and gives in a thoroughly excellent way....

SMITH. (*) "A Manual of Veterinary Physiology." By Vet. Capt. F. Smith, C. M. S., M. R. C. V. S., Examiner in Physiology, Royal College of Veterinary Surgeons, author of "A Manual of Veterinary Hygiene." A completely revised and enlarged edition just published. Cloth, 6 x 8 3-4, 720 pp, 102 illust'ns.... 4 25

The whole book has been carefully revised and brought up to date. All the important advances of the last few years have been embodied. The chapter on the nervous system has been specially revised by Prof. Sherrington, whose remarkable work on the "spinal dog" has been introduced. A special point is made of the bearing of physiology on pathology, and the utilization of physiology to the better understanding of every-day practice. The book is written by a veterinary surgeon for veterinary practitioners and students, and is the only work in the English language which can claim to be purely veterinary.

— (*) "Manual of Veterinary Hygiene." Third edition revised. Cloth, size 5 1-4 x 7 1-2, xx + 1036 pages, with 255 illustrations..... 4 75

Recognizing the rapid advance and extended field of the subject since the previous issue, the author has entirely re-written the work and enlarged its scope, which is brought thoroughly up to date. Contains over 500 more pages than the second edition.

STRANGWAY. (*)“**Veterinary Anatomy.**” Edited by 1. Vaughan, F.L.S., M.R.C.V.S. New 12th American edition revised. Cloth, size 6 1-4 x 9 1-2, 625 pages, 224 illus. 5 00

SUSSDORF. “**Six Large Colored Wall Diagrams.**” By Prof. Sussdorf, M.D. (of Göttingen). Text translated by Prof. W. Owen Williams, of the New Veterinary College, Edinburgh. Size, 44 inches by 30 inches.

- | | |
|-----------|-------------------|
| 1.—Horse. | 4.—Ox. |
| 2.—Mare. | 5.—Boar and Sow. |
| 3.—Cow. | 6.—Dog and Bitch. |

The above are printed in eight or nine colors. Showing the position of the viscera in the large cavities of the body.

Price, unmounted.....1 75 each
 “ mounted on linen, with roller... 3 50 “

VAN MATER. “**A Text Book of Veterinary Ophthalmology.**” By George G. Van Mater, M.D., D.V.S., Professor of Ophthalmology in the American Veterinary College; Oculist and Aurist to St. Martha’s Sanitarium and Dispensary; Consulting Eye and Ear Surgeon to the Twenty-sixth Ward Dispensary; Eye and Ear Surgeon, Brooklyn Eastern District Dispensary, etc. Illustrated by one chromo lithograph plate and 71 engravings. Cloth, 6 x 9 1-4, 151 pages...3 00

. . . We intend to adopt this valuable work as a text book.—*E. J. Creely, D.V.S.,* Dean of the San Francisco Veterinary College.

VETERINARY DIAGRAMS in Tabular Form. Size, 28½ in. x 22 inches. Price per set of five... 4 00
 Mounted and folded in case.....7 00
 Mounted on roller and varnished.....10 00

No. 1. “**The External Form and Elementary Anatomy of the Horse.**” Eight colored illustrations—1. External regions; 2. Skeleton; 3. Muscles (Superior Layer); 4. Muscles (Deep Layer); 5. Respiratory Apparatus; 6. Digestive Apparatus; 7. Circulatory Apparatus; 8. Nerve Apparatus; with description....1 25
 Mounted on roller and varnished.....2 25

No. 2. “**The Age of Domestic Animals.**” Forty-two figures illustrating the structure of the teeth, indicating the Age of the Horse, Ox, Sheep, and Dog, with full description 75
 Mounted on roller and varnished.....2 00

No. 3. “**The Unsoundness and Defects of the Horse.**” Fifty figures illustrating—1. The Defects of Conformation; 2. Defects of Position; 3. Infirmities or Signs of Disease; 4. Unsoundnesses; 5. Defects of the Foot; with full description..... 75
 Mounted on roller and varnished.....2 00

VETERINARY DIAGRAMS (continued).

- No. 4. "The Shoeing of the Horse, Mule and Ox."
Fifty figures descriptive of the Anatomy and Physiology of the Foot and of Horse-shoeing.....75
Mounted on roller and varnished.....2 00
- No. 5. "The Elementary Anatomy, Points, and Butcher's Joints of the Ox." Ten colored illustrations
—1. Skeleton; 2. Nervous System; 3. Digestive System (Right Side); 4. Respiratory System; 5. Points of a Fat Ox; 6. Muscular System; 7. Vascular System; 8. Digestive System (Left Side); 9. Butcher's Sections of a Calf; 10. Butcher's Sections of an Ox; with full description1 25
Mounted on roller and varnished.....2 25

WALLEY. "A Practical Guide to Meat Inspection." By Thomas Walley, M.R.C.V.S., late principal of the Edinburgh Royal (Dick) Veterinary College; Professor of Veterinary Medicine and Surgery, etc. Fourth Edition, thoroughly revised and enlarged by Stewart Stockman, M.R.C.V.S., Professor of Pathology, Lecturer on Hygiene and Meat Inspection at Dick Veterinary College, Edinburgh. Cloth, size 5 1-2 x 8 1-4, with 45 colored illus., 295 pages.... 3 00

WILCOX. (*)"Handbook of Meat Inspection." By Robert Ostertag, M.D. See "Ostertag."

WILLIAMS. "Principles and Practice of Veterinary Medicine." Author's edition, entirely revised and illustrated with numerous plain and colored plates. By W. Williams, M.R.C.V.S. Cloth, size 5 3-4 x 8 3-4, 863 pages.....7 50

— "Principles and Practice of Veterinary Surgery." Author's edition, entirely revised and illustrated with numerous plain and colored plates. By W. Williams, M.R.C.V.S. Cloth, size 6 1-2 x 9 1-4, 756 pages7 50

WINSLOW. (*)"Veterinary Materia Medica and Therapeutics." By Kenelm Winslow, B.A.S., M.D.V., M.D., (Harv.); formerly Assistant Professor of Therapeutics in the Veterinary School of Harvard University; Fellow of the Massachusetts Medical Society; Surgeon to the Newton Hospital, etc.

Sixth Edition, Revised in 1908

The most complete, progressive and scientific book on the subject in the English language. The recognized authority on Veterinary Materia Medica and the standard text-book on the subject in veterinary colleges.

Cloth, size 6 1-4 x 9 1-4, xii + 859 pages..... 6 00

WINSLOW (continued).

- (*) **“The Production and Handling of Clean Milk.”** A complete, plain, practical and authoritative guide to the production and distribution of clean milk for farmers, health officers, milk inspectors, students of agriculture and dairying, country gentlemen, physicians and others interested in matters pertaining to dairying and hygiene. The book also contains a general outline of a scheme for the control, supervision and inspection of a city milk supply.

Second edition to be published February, 1909.

WYMAN. (*) **“Bovine Obstetrics.”** By M. G. De Bruin. Translated by W. E. A. Wyman, M.D.V., V.S.

See also “De Bruin.”

- (*) **“Catechism of the Principles of Veterinary Surgery.”**
By W. E. A. Wyman, M.D.V., V.S. Cloth, size 6 x 9,
321 pages 3 50

Concerning this new work attention is called to the following points:

- 1.—It discusses the subject upon the basis of veterinary investigations.
- 2.—It does away with works on human pathology, histology, etc.
- 3.—It explains each question thoroughly both from a scientific as well as a practical point of view.
- 4.—It is written by one knowing the needs of the student.
- 5.—It deals exhaustively with a chapter on tumors, heretofore utterly neglected in veterinary pathology.
- 6.—The only work in English specializing the subject.
- 7.—The only work thoroughly taking into consideration American as well as European investigations.
- 8.—Offering practical hints which have not appeared in print, the result of large city and country practice.

- (†) **“The Clinical Diagnosis of Lameness in the Horse.”**
By W. E. A. Wyman, D.V.S., formerly Professor of Veterinary Science, Clemson A. & M. College, and Veterinarian to the South Carolina Experiment Station. Cloth, size 6 x 9 1-2, 182 pp., 32 illus.... 2 50

- (†) **“Tibio-peroneal Neurectomy for the Relief of Spavin Lameness.”** By W. E. A. Wyman, M.D.V., V.S.
Boards, size 6 x 9, 30 pages, illustrated 50

Anyone wanting to perform this operation should procure this little treatise; he will find it of considerable help.—*The Veterinary Journal.*

ZUILL. "Typhoid Fever; or Contagious Influenza in the Horse." By Prof. W. L. Zuill, M.D., D.V.S. Pamphlet, size 6 x 9 1-4, 29 pages..... 25

ZUNDEL. "The Horse's Foot and Its Diseases." By A. Zundel, Principal Veterinarian of Alsace Lorraine. Translated by Dr. A. Liautard, V.S. Cloth, size 5 x 7 3-4, 248 pages, illustrated..... 2 00

Any book sent prepaid for the price. Send for Complete Descriptive Catalogue

WILLIAM R. JENKINS CO.

851 and 853 Sixth Avenue,

NEW YORK.



JAN 78



N. MANCHESTER,
INDIANA

